

UKL MOISTURE SEPARATOR

Condensate formed due to steam condensing in the pipeline may cause problems of varied nature in a steam circuit. It is also possible that the source of condensate could be the boiler supplying wet steam to plant. It is absolutely essential to remove this condensate from the line for supply of dry steam with minimum pressure drop to this equipment.

The UKL Moisture separator is designed to remove entrained water particles from the steam so that they can be drained away as condensate. The water particles settle on the cooler baffle plates and are drained away by the unique design of the body.

This can also be used on compressed air lines.

UKL Moisture separators are well proven multi baffle designed to remove condensate with high level of efficiency and reliability.

The multi baffle design will cause total removal of condensate from steam lines that are fed by boilers generating wetness as high as 20%.

Typically contoured body design allows large flow areas to ensure low pressure drops.



MATERIAL OF CONSTRUCTION:

ASTM A 216 Gr. WCB

END CONNECTIONS:

Flanged End ANSI Class 150/300

INSTALLATION:-

Preferably in Horizontal Position

LIMITING CONDITIONS:-

Class	Temperature	38 ^o C	200 ^o C	300 ^o C	325 ^o C	360 ^o C	375 ^o C	400 ^o C	425 ^o C
#150	Pressure (bar)	19.6	13.8	10.2	9.3	8	7.4	6.5	5.5
#300		51.1	43.8	39.8	38.7	37.1	36.4	34.7	28.8

AVAILABLE SIZES:

25,40,50 , 65,80, 100, 125, 150 and 200 NB.

OPTIONAL:-

Flanged ANSI #150/#300

Drain Plug with TD Trap module

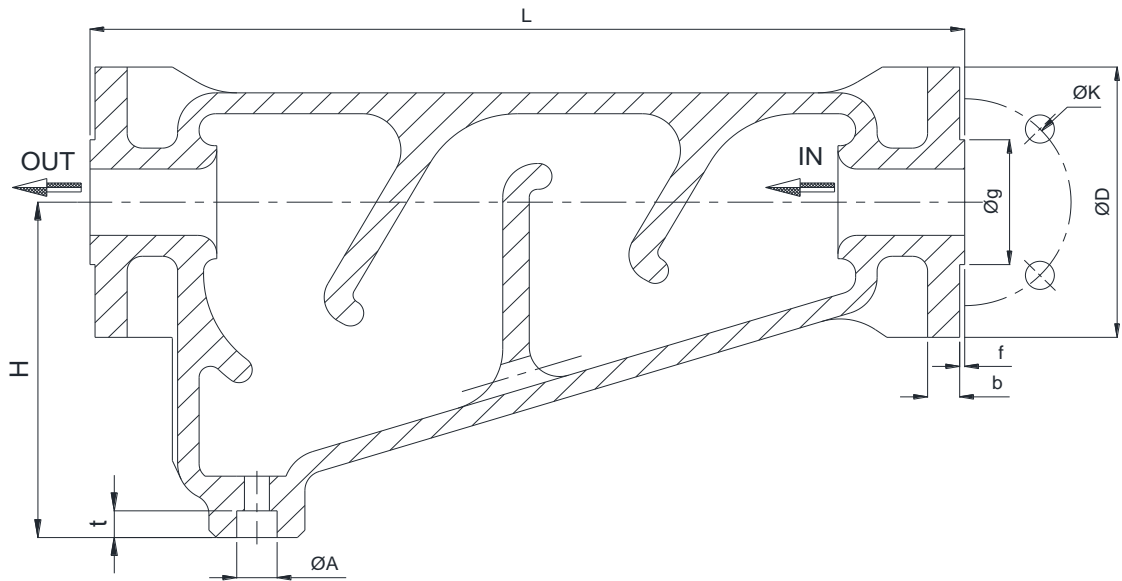

UMS FLANGED END #150 Dimensions (mm)

Sr.	Size	L	H	ØD	Øg	ØK	ØI	b	f	No. Of Holes; N	ØA NPT
1	25	347.00	134.50	110.00	50.80	79.40	16.00	12.70	2.0	4	3/4"
2	40	359.00	126.00	125.00	73.00	98.40	16.00	15.90	2.0	4	3/4"
3	50	458.00	144.00	150.00	92.10	120.70	19.05	17.50	2.0	4	1"
4	65	465.00	144.00	180.00	104.80	139.7	19.05	20.70	2.0	4	1"
5	80	487.00	173.00	190.00	127.00	152.4	19.05	22.30	2.0	4	1"
6	100	696.00	236.00	230.00	157.20	190.5	19.05	22.30	2.0	8	1"
7	125	696.00	236.00	255.00	185.70	215.9	22.22	22.30	2.0	8	1"
8	150	707.00	252.00	280.00	215.90	241.3	22.22	23.90	2.0	8	1"
9	200	762.00	310.00	345.00	269.90	298.5	22.22	27.00	2.0	8	1"

UMS FLANGED END #300 Dimensions(mm)

Sr.	Size	L	H	ØD	Øg	ØK	b	f	No. Of Holes, N	ØA
1	25	353	100	125	50.8	88.9	15.9	2	4	3/4"
2	40	366	125	155	73	114.3	19.1	2	4	3/4"
3	50	465	135	165	92.1	127	20.4	2	4	1"
4	65	471	144	190	104.8	149.2	23.9	2	8	1"
5	80	496	173	210	127	168.3	27	2	8	1"
6	100	712	236	255	157.2	200	30.2	2	8	1"
7	125	720	236	280	185.7	235	33.4	2	8	1"
8	150	729	252	320	215.9	269.9	35	2	12	1"
9	200	788	310	380	269.9	330.2	39.7	2	12	1"



Cast / Forged Steel Piston Valves, Bellow Seal Valves, High Pressure valves (Gate/Globe), Strainers – "Y" Type, Flash Vessel., ITVS Steam Traps (Thermodynamic, Thermostatic, Ball Float Traps, Inverted Bucket), Pressure Reducing Station, Condensate Recovery Products. Level Gauges (Reflex, Transparent, Bicolor), Sight Glass, Hot Water Generation System, Safety and Relief Valves.
FSD Products : Compressed Asbestos / Non Asbestos Fiber Sheeting / Cut Gaskets, Spiral Wound Gaskets.

In view of technical progress design and dimensions are subjected to change without notice.



UNI KLINGER LIMITED

A joint venture of the Neterwala group of companies and KLINGER AG. Switzerland.

Central Sales Office & Pune Branch : SC1, 5th Fl., Kohinoor Est. Mumbai-Pune Highway, Khadki, Pune-411 003. Tel.: +91-20-4102 3000 Fax.: (020) 4102 3001
 e-mail : salesco@uniklinger.com, salespune@uniklinger.com, Website : www.uniklinger.com

Factory : C-37, M.I.D.C., Ahmednagar – 414 111, Maharashtra, Tel. : 0241 – 2777223/2777512 Fax : 0241 – 2777294, E-mail : fdworks@uniklinger.com

Branch Offices :

Baroda : 102, 1st Floor, Otel Towers-II R.C. Dutt Road, Baroda-390 005, Tel.: 91-0265-2312343 / 2340660, Fax.: 91-265-2341419. E-mail : salesbar@uniklinger.com
Chennai : East Coast Centre, 5th Floor, 553, Mount road, Teyanampet, Chennai - 600 018, Tel.: 91 - 44 - 24345707. Fax.: 91 - 44 - 24343960. E-mail : saleschen@uniklinger.com
Kolkata : 9, Chitrakoot, 8th Floor, 230 A, A.J.C Bose road, Kolkatta-700 020, Tel.: 91-33-22872510, Fax.: 91-33-22876494. E-mail : salescal@uniklinger.com
Mumbai : 22, 2nd Flr, Shreeji Arcade CHS, Almeda road, Thane-400 602, Tel.: 91-22-25421140 / 91-22-25440461, Fax.: 91-22-25440463. E-mail : salesmum@uniklinger.com
Delhi : 321, Ansal Chamber-II, 6, Bhikaji Cama Place, New Delhi-110 066, Tel.: 91-11-41658767 / 91-11-26193847, Fax.: 91-11-41658768. E-mail : salesdel@uniklinger.com