

Butterfly Valve

ISORIA 10/16

DN 40 - 1000

PS 10 bar: ISORIA 10

PS 16 bar: ISORIA 16

Type Series Booklet



Legal information/Copyright

Type Series Booklet ISORIA 10/16

All rights reserved. The contents provided herein must neither be distributed, copied, reproduced, edited or processed for any other purpose, nor otherwise transmitted, published or made available to a third party without the manufacturer's express written consent.

Subject to technical modification without prior notice.

© KSB S.A.S, Gennevilliers (Paris), France 04/06/2021

Contents

Butterfly Valves.....	4
Centred-disc Butterfly Valves	4
ISORIA 10/16	4
Main applications.....	4
Fluids handled	4
Operating data.....	5
Design details.....	5
Valve body materials.....	5
Product benefits.....	5
Product information	6
PED 2014/68/EU Fluids in Groups 1 and 2	6
EC Machinery Directive 2006/42/EC.....	6
Product information as per Regulation No. 1907/2006 (REACH)	6
Product information as per Directive 2014/34/EU (ATEX).....	6
Certifications	6
Related documents	6
Purchase order specifications	6
Technical data	7
Permissible pressures for liners.....	7
Vacuum resistance.....	7
Hydraulic characteristics of butterfly valves.....	7
Actuating torques	8
Materials.....	9
Variants.....	13
Dimensions and weights.....	14
Dimensions of ISORIA 10/16	14
Manual override.....	14
Dimensions and weights of ISORIA 10/16 + S / SR lever.....	15
Dimensions and weights of ISORIA 10/16 + SP lever.....	15
Dimensions and weights of ISORIA 10/16 + CR / CM lever	16
Dimensions and weights of ISORIA 10/16 + MR manual gearbox.....	17
Line connections.....	19
Installation information.....	23
Dead-end service and downstream dismantling.....	23
Flange dimensions.....	24
Coated flange.....	25
Bolting and weights.....	26
Bolting and weights for wafer-type body - T1.....	26
Bolting and weights for semi-lug body - T2.....	29
Bolting and weights for full-lug body with flat faces - T3	32
Bolting and weights for full-lug body with raised faces - T4.....	35
Bolting and weights for flanged body with flat faces - T5 DN 150 - 600.....	38
Bolting and weights for flanged body with flat faces - T5 DN 650 - 600.....	40

Butterfly Valves

Centred-disc Butterfly Valves

ISORIA 10/16



Main applications

- Water extraction
- Chemical industry
- Cooling circuits
- Seawater desalination/reverse osmosis
- Flue gas desulphurisation
- Food industry / beverage industry
- Paper industry / pulp industry
- Spray irrigation systems
- Descaling units
- General irrigation systems
- Washing plants
- Paint shops
- Shipbuilding
- Mixing
- Mining
- Pipelines and tank farms
- Swimming pools
- Process engineering
- Sugar industry
- Pressure boosting
- Industrial recirculation systems
- Water treatment
- Fire-fighting systems

Fluids handled

- Condensate
- Cleaning agents
- Distillate

- Wash water
- Seawater
- Service water
- Cooling water
- Fire-fighting water
- Drinking water
- Brackish water
- Waste water
- River water, lake water and groundwater
- Abrasive fluids
- Aggressive fluids
- Fluids containing mineral oils
- Solids-laden fluids
- Fluids containing gas
- Corrosive fluids
- Explosive fluids
- Inorganic fluids
- Organic fluids
- Polymerising/crystallising fluids
- Radioactive fluids
- Toxic fluids
- Volatile fluids
- Gas
- Oil
- Brine
- Solvents

Operating data

Table 1: Operating properties

Characteristic	Value	
	ISORIA 10	ISORIA 16
Nominal pressure	PN 10	PN 16
Nominal size	DN 40 - 1000	DN 40 - 1000
Max. permissible pressure [bar]	10	16
Min. permissible temperature [°C]	≥ -10	≥ -10
Max. permissible temperature [°C]	≤ +200	≤ +200
Actuation at ΔP [bar] at ambient temperature	10 max.	16 max.
Vacuum operation down to	0.3 bar absolute	
Max. permissible flow velocity at operating pressure	1.5 to 3 m/s (max.) for water	
Temperature with		
▪ XA liner	▪ -20 °C to +90 °C	
▪ XC liner	▪ -20 °C to +90 °C	
▪ XV liner	▪ -20 °C to +130 °C	
▪ K liner	▪ -5 °C to +90 °C	
▪ CB liner	▪ -5 °C to +100 °C	
▪ CC liner	▪ 0 °C to +60 °C	
▪ NB liner	▪ -30 °C to +60 °C	
▪ NH liner	▪ -5 °C to +130 °C	
▪ Y liner	▪ -5 °C to +100 °C	
▪ VC liner	▪ 0 °C to +200 °C	
▪ EG liner	▪ -25 °C to +100 °C	
▪ SK liner	▪ -30 °C to +200 °C	

Liner pressure limits based on pressure/materials table for liners

Design details

Design

- Wafer-type body with flat faces - T1: DN 40 - 1000
- Semi-lug body - T2: DN 40 - 600
- Full-lug body with flat faces - T3: DN 40 - 600
- Full-lug body with raised faces - T4: DN 40 - 600
- Flanged body with flat faces - T5: DN 650 to 1000 (DN 150 to 600 on request)
- Downstream dismantling possible with body types T2, T3, T4 and T5
- Dead-end service with counterflange possible with all body types
- Body with polyurethane coating, thickness 80 µm, colour: RAL 5002, blue
- Valve disc made of nodular cast iron, epoxy-coated, thickness 80 µm, colour: RAL 8012, brown
- Design to EN 593 and ISO 10631
- Top flange to ISO 5211
- Marking in accordance with EN 19
- Absolutely tight shut-off (no leakage visible to the naked eye) in either direction of flow in accordance with EN 12266-1, leakage rate A, and ISO 5208, category A.
- EN, ASME, JIS, AWWA connections possible.
- Face-to-face length to ISO 5752-20 and EN 558-1-20

Variants

- Butterfly valve cleaned and packaged, free from paint wetting impairment substances
- S / SR / SP / CR / CM quarter-turn levers
- MR manual gearbox
- Electric quarter-turn actuators
- ACTAIR NG / DYNACTAIR NG pneumatic actuators
- HQ hydraulic actuators
- AMTROBOX for open/closed position signalling
- AMTRONIC position signalling and control air supply
- SMARTRONIC positioner and process controller
- Anti-static design for manually actuated valves

Valve body materials

Table 2: Overview of available materials

Material	Material number	Type	DN	KSB code
EN-GJL-250	JL 1040	T1	DN 40-600	3t
EN-JS1030	JS 1030	T1	DN 650-1000	3g
ASTM A536 Gr. 60.40.18				
EN-JS1030	JS 1030	T2	DN 40-600	3g
ASTM A 216 Gr. CCC		T3	DN 40-600	1
EN-JS1030	JS 1030	T4	DN 40-600	3g
EN-JS1030	JS 1030	T5	DN 150-600	3g
EN-JS1030	JS 1030	T5	DN 650-1000	3g
ASTM A536 Gr. 60.40.18				

Product benefits

- Spherically machined disc with rounded sealing contour
 - ensures durable and permanently tight shut-off
- Splined or keyed connection without play between shaft and valve disc
 - Dry shaft, no contact with fluid handled
- Sealing to atmosphere is ensured,
 - even when the actuator has been removed

- Marking indicates position of valve disc
- Shaft and actuating shaft in anti-blowout design with screw or circlip
 - Shaft and actuating shaft are retained in the body.
- Valve equipped with stainless steel bearing bushes with reinforced PTFE coating
- The elastomer liner provides tight sealing at the flanged line connections, eliminating the need for an extra gasket.
- Valve actuation options
 - Manual
 - Electric
 - Pneumatic
 - Hydraulic

Product information

PED 2014/68/EU Fluids in Groups 1 and 2

The valves satisfy the safety requirements of Annex I of the European Pressure Equipment Directive 2014/68/EU (PED) for fluids in Groups 1 and 2.

EC Machinery Directive 2006/42/EC

Valves with actuators can meet the requirements of the 2006/42/EC Machinery Directive for partly completed machinery.

Product information as per Regulation No. 1907/2006 (REACH)

For information as per chemicals Regulation (EC) No. 1907/2006 (REACH), see <https://www.ksb.com/ksb-en/About-KSB/Corporate-responsibility/reach/>.

Product information as per Directive 2014/34/EU (ATEX)

The valves do not have a potential internal source of ignition and can be used in potentially explosive atmospheres, Group II, category 2 (zones 1+21) to ATEX 2014/34/EU.

Certifications

Table 3: Overview

Label	Effective in:	Comment
	Worldwide	
	Germany	Approved in accordance with the German drinking water regulation
	Switzerland	Approved in accordance with Swiss drinking water regulation
	Belgium	Approved in accordance with the Belgian drinking water regulation
	United Kingdom	Approved in accordance with the UK drinking water regulation
	France	Approved in accordance with the French drinking water regulation
	Worldwide	Elastomeric parts meet FDA standards.
	Worldwide	Approved for marine applications
	Worldwide	Approved for marine applications
NF Rob Gaz	France	Approved for gas applications
	Germany	Approved for gas applications
	-	Certificate regarding food contact materials as per European Regulation (EC) No. 1935/2004

Related documents

Table 4: Information/documents

Document	Reference number
Operating manual	8449.8

Purchase order specifications

1. Type
2. Nominal pressure
3. Nominal size
4. Fluid handled
5. Flow rate / flow velocity
6. Operating temperature
7. Materials (body, valve disc, seat)
8. Line connection, flange facing and flange surface quality
9. Actuator / automation
10. Reference number

Technical data

Permissible pressures for liners

Table 5: ISORIA 10

DN	NPS [inch]	Max. permissible pressure PS [bar]				
		XA - XC - XV - K - Y - CB	NH	VC	EG	CC - SK - NB
40-300	1½-12	10	10	10	10	6
350-500	14-20	10	6	10	10	6
550	22	10	6	10	-	-
600	24	10	6	10	10	6
650	26	10	6	-	-	-
700	28	10	6	6	-	-
750	30	10	6	-	-	-
800-1000	32-40	10	6	6	-	-

Table 6: ISORIA 16

DN	NPS [inch]	Max. permissible pressure PS [bar]	
		XA - XC - XV - K	Y
40-600	1½-24	16	16
650-1000	26-40	16	-

Vacuum resistance

Table 7: Vacuum resistance data

DN	NPS [inch]	Liner mounting method	Min. pressure	Max. temperature
			[bar absolute]	All liners
40-300	1½-12	Non-glued (standard)	$1,33 \cdot 10^{-5}$ (10^2 torr)	See "Operating data"
350-1000	14-40	Non-glued (standard)	0,3	
350-1000	14-40	Glued (optional)	$1,33 \cdot 10^{-5}$ (10^2 torr)	80 °C

Hydraulic characteristics of butterfly valves

Table 8: Table: Kv0 and Cv0 [mm]

DN	NPS [inch]	Flow coefficient with valve disc fully open		Zeta
		Kv0	Cv0	
40	1½	53	62	1,46
50	2	133	154	0,56
65	2½	240	280	0,49
80	3	410	475	0,39
100	4	655	760	0,37
125	5	900	1044	0,48
150	6	1800	2090	0,25
200	8	3550	4120	0,20
250	10	7350	8453	0,12
300	12	9100	10465	0,16
350	14	11200	12880	0,19
400	16	14800	17020	0,19
450	18	19700	22655	0,17
500	20	25000	28750	0,16
550	22	31700	36455	0,15
600	24	36400	41860	0,16
650	26	37700	43730	0,20
700	28	47500	55100	0,17
750	30	51500	59740	0,19
800	32	63500	73660	0,16
900	36	84700	98250	0,15
1000	40	108500	125860	0,14

Actuating torques

A safety coefficient has already been included in the actuating torques for actuator selection.

Table 9: Table: actuating torques [Nm] for ISORIA 10

DN	NPS	Liners XA, XC, XV, K with lubricating fluid	All liners with non-lubricating fluid and ¹⁾
	[inch]		
40	1½	8	16
50	2	16	24
65	2½	24	32
80	3	32	40
100	4	48	56
125	5	64	80
150	6	104	112
200	8	136	168
250	10	198	297
300	12	342	468
350	14	450	648
400	16	585	882
450	18	720	1080
500	20	900	1350
550	22	1080	1620
600	24	1260	1890
650	26	1700	2600
700	28	2000	3000
750	30	2300	3500
800	32	2600	4000
900	36	3400	5000
1000	40	4100	6000

Table 10: Table: actuating torques [Nm] for ISORIA 16

DN	NPS	Liners XA, XC, XV, K with lubricating fluid only
	[inch]	
40	1½	16
50	2	24
65	2½	32
80	3	40
100	4	56
125	5	80
150	6	112
200	8	168
250	10	297
300	12	468
350	14	648
400	16	882
450	18	1080
500	20	1350
550	22	1620
600	24	1890
650	26	3200
700	28	3600
750	30	3900
800	32	4000
900	36	5000
1000	40	6000

¹⁾ Other liners (except XA, XC, XV, K) with lubricating fluid

Materials

Table 11: Sectional drawing

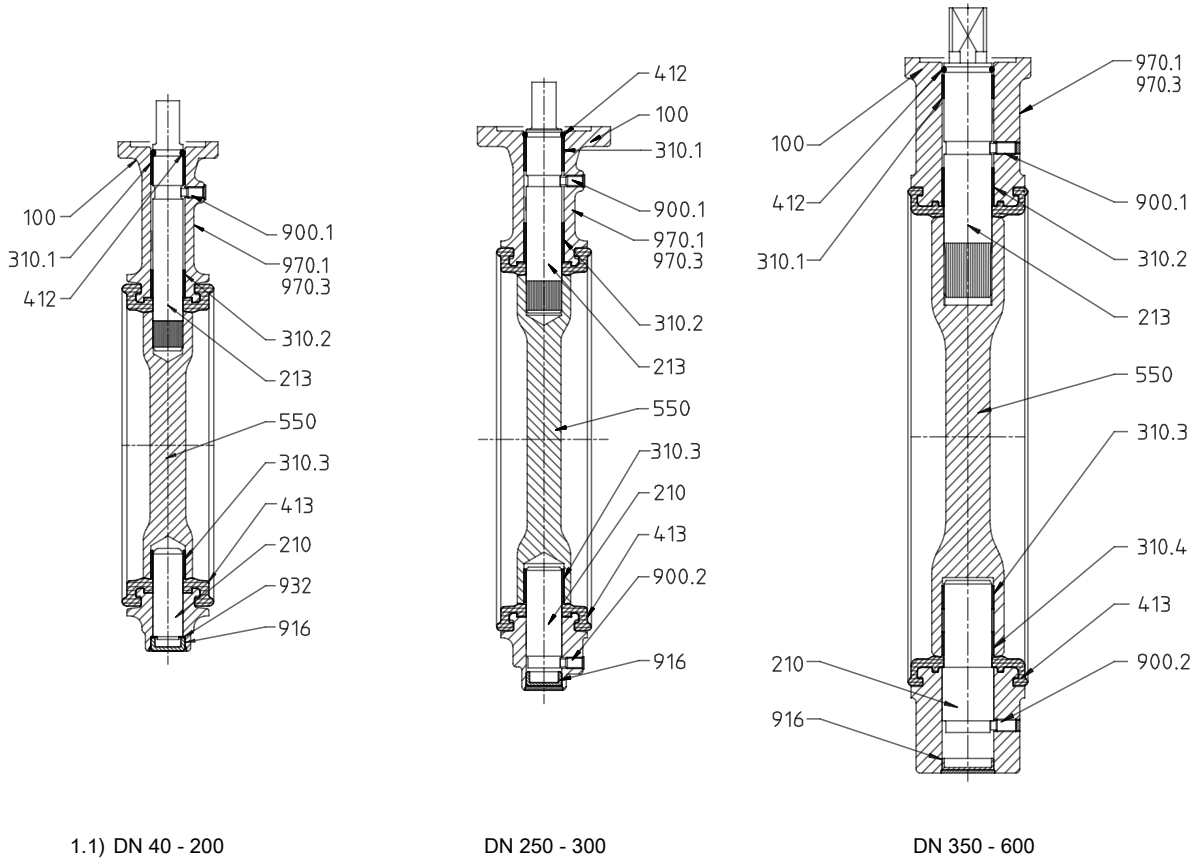
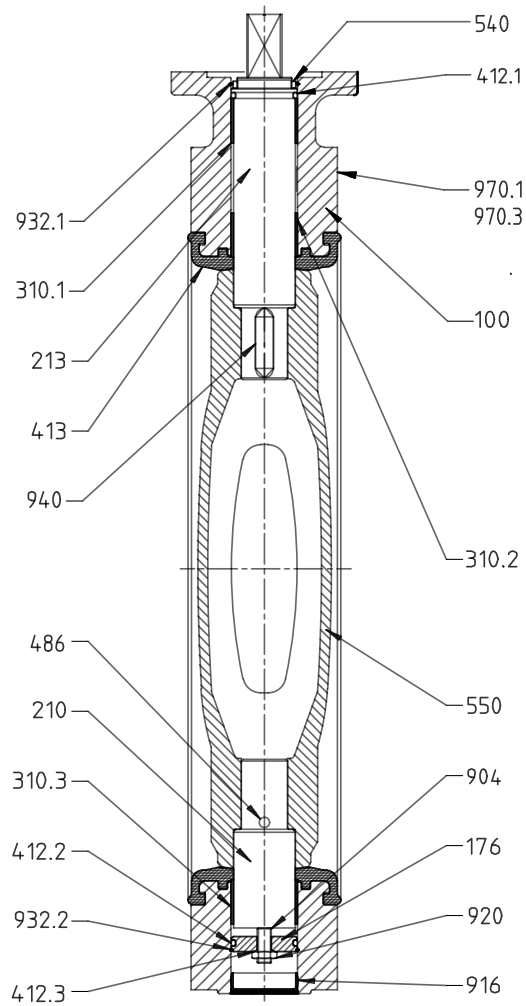

Fig. 1: Sectional drawings of ISORIA 10/16 for DN 40 - 600

1.1) Parts 310.1, 310.2, 310.3 for DN 200 only



DN 650 - 1000

Fig. 2: Sectional drawings of ISORIA 10/16 for DN 650 - 1000

Table 12: List of components

Part No.	Description	DN	Materials	KSB code
100	Body T1	40 - 600	Lamellar graphite cast iron JL1040	3t
100	Body T1	650 - 1000	Nodular cast iron JS1030 ASTM A536 Gr. 60.40.18	3g
100	Body T2	40 - 600	Nodular cast iron JS1030	3g
100	Body T3	40 - 600	Steel	1
100	Body T4	40 - 600	Nodular cast iron JS1030	3g
100	Body T5	150 - 600	Nodular cast iron JS1030	3g
100	Body T5	650 - 1000	Nodular cast iron JS1030 ASTM A536 Gr. 60.40.18	3g
176	Bottom	650 - 1000	Steel	
210 ²⁾	Shaft	40 - 600	Stainless steel 1.4028 (13 % Cr)	6k
210 ²⁾	Shaft	650 - 1000	Stainless steel 1.4028 (13 % Cr)	6k
210 ²⁾	Shaft	40 - 600	Stainless steel 1.4057 (17 % Cr)	6h
210 ²⁾	Shaft	650 - 1000	Stainless steel 1.4542 (17 % Cr)	6e
213 ²⁾	Actuating shaft	40 - 600	Stainless steel 1.4028 (13 % Cr)	6k
213 ²⁾	Actuating shaft	650 - 1000	Stainless steel 1.4028 (13 % Cr)	6k
213 ²⁾	Actuating shaft	40 - 600	Stainless steel 1.4057 (17 % Cr)	6h
213 ²⁾	Actuating shaft	650 - 1000	Stainless steel 1.4542 (17 % Cr)	6e
310.1 ²⁾	Plain bearing	200 - 1000	Steel with reinforced PTFE coating	
310.2 ²⁾	Plain bearing	200 - 1000	Steel with reinforced PTFE coating	
310.3 ²⁾³⁾	Plain bearing	200 - 1000	Steel with reinforced PTFE coating	
310.4 ²⁾³⁾	Plain bearing	350 - 600	Steel with reinforced PTFE coating	
412 ²⁾³⁾⁴⁾	O-ring	40 - 600	Nitrile	
412.1 ²⁾³⁾⁴⁾	O-ring	650 - 1000	Nitrile	
412.2 ²⁾³⁾⁴⁾	O-ring	650 - 1000	Nitrile	
412.3 ²⁾³⁾⁴⁾	O-ring	650 - 1000	Nitrile	
413 ⁴⁾	Liner	40 - 1000	EPDM	XA
413 ⁴⁾	Liner	40 - 1000	EPDM suitable for drinking water	XC
413 ⁴⁾	Liner	40 - 1000	EPDM, heat-resistant	XV
413 ⁴⁾	Liner	40 - 1000	High-grade nitrile	K
413 ⁴⁾	Liner	40 - 1000	Carboxylated nitrile	CB ⁵⁾
413 ⁴⁾	Liner	40 - 600	Carboxylated nitrile, white	CC ⁵⁾
413 ⁴⁾	Liner	40 - 1000	HYPALON (chlorosulfonated) polyethylene	Y
413 ⁴⁾	Liner	40 - 1000	VITON, heat-resistant fluoroelastomer	VC ⁵⁾
413 ⁴⁾	Liner	40 - 1000	Epichlorohydrin	EG ⁵⁾
413 ⁴⁾	Liner	40 - 1000	Silicone, heat-resistant	SK ⁵⁾
413 ⁴⁾	Liner	40 - 1000	Polybutadiene natural rubber	NB ⁵⁾
413 ⁴⁾	Liner	40 - 1000	Hydrogenated nitrile butadiene rubber (HNBR)	NH ⁵⁾
486 ²⁾	Ball	650 - 1000	Steel	
540 ²⁾³⁾⁴⁾	Bush	650 - 1000	Acetal	
550 ³⁾	Valve disc	40 - 1000	Nodular cast iron JS1030	3g
550 ³⁾	Valve disc	650 - 1000	Nodular cast iron JS 1030 ASTM A536 Gr. 60.40.18	3g
550 ³⁾	Valve disc	40 - 600	Nodular cast iron JS 1030, Halar-coated	3a
550 ³⁾	Valve disc	40 - 1000	Nodular cast iron JS 1030, Ebonite-coated	3p ⁵⁾
550 ³⁾	Valve disc	40 - 1000	Nodular cast iron JS 1030, Rilsan-coated	3r ⁵⁾
550 ³⁾	Valve disc	40 - 300	Nodular cast iron JS 1030, EPDM-coated	3x ⁵⁾
550 ³⁾	Valve disc	40 - 200	Stainless steel 1.4401	6
550 ³⁾	Valve disc	250 - 1000	Stainless steel 1.4408 / ASTM A351 Gr. CF8M	6
550 ³⁾	Valve disc	40 - 200	Stainless steel 1.4401, polished	6i

- ² Part from shaft spare parts kit
³ Part from valve disc spare parts kit
⁴ Part from liner spare parts kit
⁵ For ISORIA 10 only

Part No.	Description	DN	Materials	KSB code
550 ³⁾	Valve disc	250 - 600	Stainless steel 1.4408 / ASTM A351 Gr. CF8M, polished	6i
550 ³⁾	Valve disc	40 - 1000	Aluminium bronze CC333G	2
550 ³⁾	Valve disc	40 - 1000	ASTM A890 Gr. CD4MCu, equivalent of NORIDUR	5a ⁵⁾
550 ³⁾	Valve disc	40 - 1000	ASTM A890 Gr. CE3MN, equivalent of NORICLOR	5g ⁵⁾
550 ³⁾	Valve disc	40 - 1000	Austenitic stainless steel, URANUS B6	6u ⁵⁾
550 ³⁾	Valve disc	40 - 1000	HASTELLOY C	7c ⁵⁾
900.1 ²⁾³⁾⁴⁾	Shaft anti-blow out device (screw)	40 - 1000	Stainless steel	
900.2 ²⁾³⁾⁴⁾	Shaft anti-blow out device (screw)	250 - 1000	Stainless steel	
904 ²⁾	Adjusting screw	650 - 1000	Steel	
916 ²⁾³⁾⁴⁾	Plug	40 - 1000	Polyethylene	
920 ²⁾	Nut	650 - 1000	Galvanised steel	
932 ²⁾³⁾⁴⁾	Serrated washer	40 - 200	Steel	
932.1 ²⁾³⁾⁴⁾	Circlip	650 - 1000	Steel	
932.2 ²⁾³⁾⁴⁾	Circlip	650 - 1000	Steel	
940 ²⁾	Key	650 - 1000	Steel	
970.1	Name plate	40 - 600	Adhesive polyester	
970.1	Name plate	650 - 1000	Stainless steel	
970.3	Name plate	40 - 1000	Stainless steel	

Variants

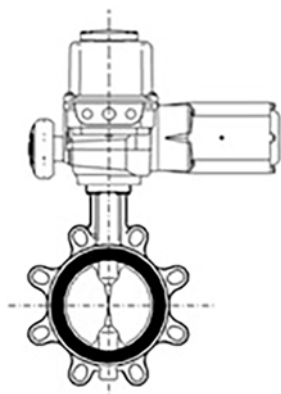

Electric actuator

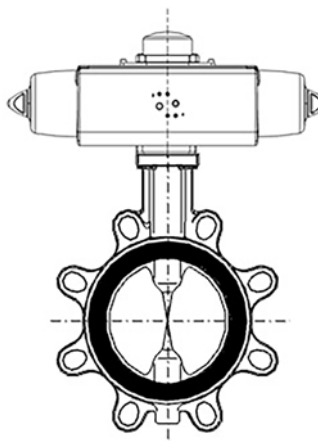

ACTAIR NG / DYNACTAIR NG pneumatic actuator

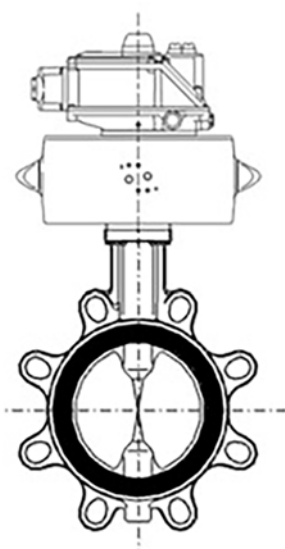

AMTRONIC / SMARTRONIC compressed air supply, positioner

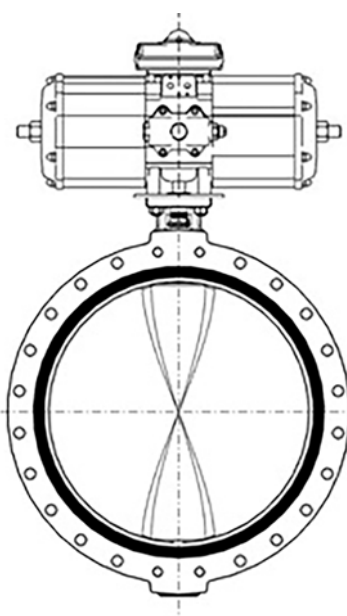

Limit switch box AMTROBOX, AMTROBOX S, AMTROBOX R, AMTROBOX EEx-ed, AMTROBOX EEx-ia

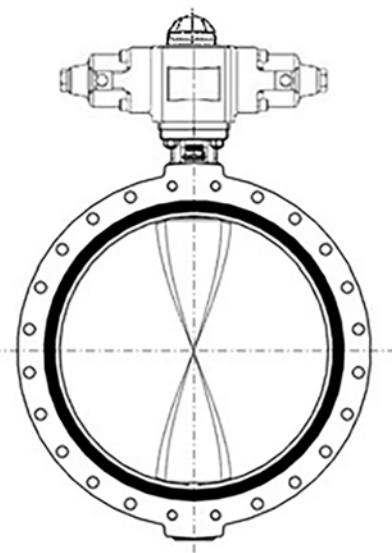

HQ hydraulic actuator

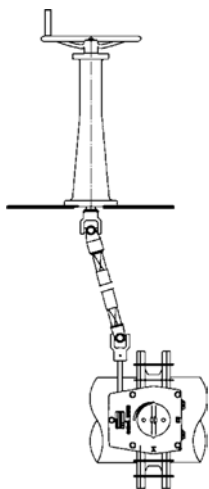

Deck stand

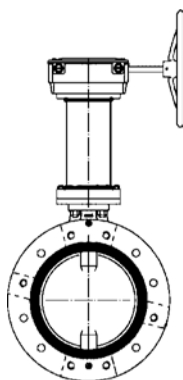

Extension

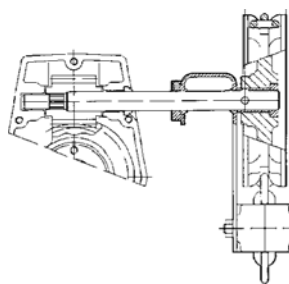

Chain wheel

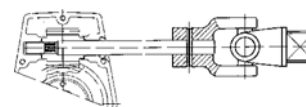

Cardan connection

Dimensions and weights

Dimensions of ISORIA 10/16

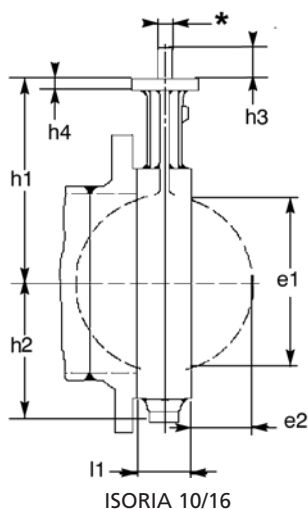

* Flat end s in $\varnothing z$ or $\varnothing s$

Table 13: Dimensions [mm]

DN	NPS [inch]	l1	h1	h2	Top flange to ISO 5211		Shaft end Flat end			Shaft end Square end		Valve disc	
					No.	h4	s	$\varnothing z$	h3	$\varnothing s$	h3	e1	e2
40	1½	33	105	51	F05	10	11	14	24	/	/	32	4
50	2	43	109	55	F05	10	11	14	24	/	/	33	4
65	2½	46	136	67	F05	10	11	14	24	/	/	55	11
80	3	46	142	73	F05	10	11	14	24	/	/	71	17
100	4	52	163	92	F05	10	14	18	24	/	/	90	23
125	5	56	176	105	F05	10	14	18	30	/	/	119	35
150	6	56	194	120	F07	12	14	18	30	/	/	144	46
200	8	60	222	150	F07	12	19	25	35	/	/	196	69
250	10	68	255	194	F10	15	19	25	35	/	/	249	92
300	12	78	282	226	F12	18	22	28	40	/	/	297	111
350	14	78	335	269	F12	23	/	/	/	25	45	326	127
400	16	102	380	298	F14	23	/	/	/	36	55	370	140
450	18	114	410	329	F14	23	/	/	/	36	55	422	160
500	20	127	440	359	F14	27	/	/	/	36	55	470	178
550	22	154	475	406	F16	27	/	/	/	50	65	522	195
600	22	154	495	439	F16	27	/	/	/	50	65	566	215
650	26	165	535	451	F16	26	/	/	/	50	65	620	235
700	28	165	560	482	F16	26	/	/	/	50	65	671	260
750	30	190	590	513	F16	26	/	/	/	50	65	717	273
800	32	190	615	546	F16	26	/	/	/	50	65	769	298
900	36	203	665	588	F25	30	/	/	/	60	80	869	341
1000	40	216	735	646	F25	30	/	/	/	60	80	970	385

Manual override

The selection of actuators given below typically applies to butterfly valves handling lubricating fluids at the maximum flow velocities shown.

For valves handling non-lubricating fluids (gas), a max. flow velocity of 50 m/s applies.

Higher flow velocities and further actuator/valve combinations are possible, depending on the operating conditions and hydraulic characteristics. Please contact us.

Dimensions and weights of ISORIA 10/16 + S / SR lever

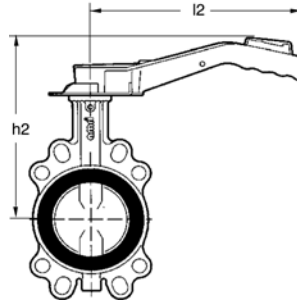

Unit comprising ISORIA 10/16 + S / SR lever

S lever: can be locked in end positions
SR lever: can be locked in 9 positions

Table 14: Actuation via S / SR lever [mm]

DN	NPS [inch]	Max. velocity [m/s]	l2	h2	[kg] ⁶⁾
40	1½	3,0	180	160	0,5
50	2	3,0	180	165	0,5
65	2½	3,0	180	191	0,5
80	3	3,0	180	197	0,5
40	1½	3,0	260	180	0,6
50	2	3,0	260	185	0,6
65	2½	3,0	260	211	0,6
80	3	3,0	260	217	0,6
100	4	3,0	330	248	0,7
125	5	3,0	330	262	0,7
150	6	3,0	330	279	0,7

Dimensions and weights of ISORIA 10/16 + SP lever

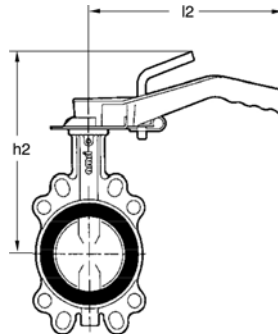

Unit comprising ISORIA 10/16 + SP lever

SP lever: can be locked in any position

Table 15: Actuation via SP lever [mm]

DN	NPS [inch]	Max. velocity [m/s]	l2	h2	[kg] ⁷⁾
40	1½	3,0	260	205	0,7
50	2	3,0	260	210	0,7
65	2½	3,0	260	236	0,7
80	3	3,0	260	242	0,7
100	4	3,0	330	263	0,8
125	5	3,0	330	277	0,8
150	6	3,0	330	294	0,8

8445.5 /05-EN

⁶⁾ The weights given refer to the actuating element.

⁷⁾ The weights given refer to the actuating element.

Dimensions and weights of ISORIA 10/16 + CR / CM lever

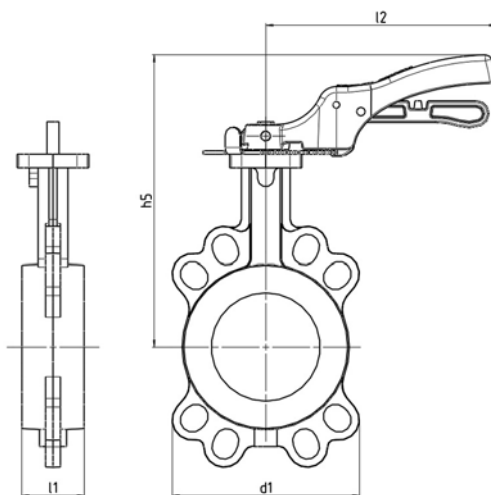

Unit comprising ISORIA 10/16 + CR / CM lever

Table 16: Actuation via CR / CM lever [mm]

DN	NPS	Max. velocity	l1	d1	l2	h5	[kg] ⁸⁾
	[inch]	[m/s]					
40	1½	3,0	33	108	CR165	175	0,8
50	2	3,0	43	118	CR165	179	0,8
65	2½	3,0	46	132	CR165	206	0,8
80	3	3,0	46	138	CR165	212	0,8
100	4	3,0	52	150	CR230	246	1,2
125	5	3,0	56	234	CR300	272	1,7
150	6	3,0	56	260	CR300	290	1,7
200	8	3,0	60	322	CR510 ⁹⁾	332	3,1
250	10	3,0	68	394	CR510 ⁹⁾	365	3,1
300	12	3,0	78	462	CR510 ⁹⁾	392	3,1

⁸⁾ The weights given refer to the actuating element.

⁹⁾ High actuating torque, manual gearbox recommended

Dimensions and weights of ISORIA 10/16 + MR manual gearbox

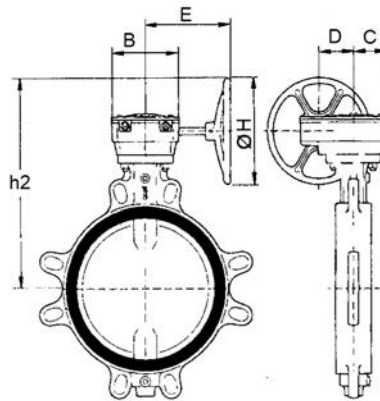

Unit comprising ISORIA 10/16 + MR manual gearbox

Table 17: Actuation via MR manual gearbox for ISORIA 10 (with lubricating fluid, with liners XA, XC, XV and K) [mm]

DN	NPS	Max. velocity	Type	B	C	D	E	H	h2	[kg] ¹⁰⁾
	[inch]	[m/s]								
40	1½	3,0	MR25	115	57	56	181	225	256	6
50	2	3,0	MR25	115	57	56	181	225	261	6
65	2½	3,0	MR25	115	57	56	181	225	287	6
80	3	3,0	MR25	115	57	56	181	225	293	6
100	4	3,0	MR25	115	57	56	181	225	314	6
125	5	3,0	MR25	115	57	56	181	225	328	6
150	6	3,0	MR25	115	57	56	181	225	345	6
200	8	3,0	MR25	115	57	56	181	225	373	6
250	10	3,0	MR25	115	57	56	181	225	406	6
300	12	3,0	MR50	134	63	66	189	225	445	7,5
350	14	3,0	MR50	134	63	66	189	225	498	7,5
400	16	3,0	MR100	165	79	78	243	350	617	14
450	18	2,5	MR100	165	79	78	243	350	647	14
500	20	2,5	MR100	165	79	78	243	350	677	14
550	22	2,0	MR200	240	90	116	263	350	723	21,5
600	24	2,5	MR200	240	90	116	263	350	743	21,5
650	26	2,0	MR200	240	90	116	263	350	783	21,5
700	28	2,0	MR200	240	90	116	263	350	808	21,5
750	30	2,0	MR400	459	115	125	332	350	860	58
800	32	2,0	MR400	459	115	125	332	350	885	58
900	36	1,5	MR400	459	115	125	332	350	898	58
1000	40	1,5	MR400	459	115	125	332	350	1005	58

¹⁰⁾ The weights given refer to the actuating element.

Table 18: Actuation via MR manual gearbox for ISORIA 10 (with lubricating fluid, with liners other than XA, XC, XV and K) and for ISORIA 16 (with lubricating fluid, with liners XA, XC, XV and K) [mm]

DN	NPS	Max. velocity	Type	B	C	D	E	H	h2	[kg] ¹¹⁾
	[inch]	[m/s]								
40	1½	3,0	MR25	115	57	56	181	225	256	6
50	2	3,0	MR25	115	57	56	181	225	261	6
65	2½	3,0	MR25	115	57	56	181	225	287	6
80	3	3,0	MR25	115	57	56	181	225	293	6
100	4	3,0	MR25	115	57	56	181	225	314	6
125	5	3,0	MR25	115	57	56	181	225	328	6
150	6	3,0	MR25	115	57	56	181	225	345	6
200	8	3,0	MR25	115	57	56	181	225	373	6
250	10	3,0	MR50	134	63	66	189	225	418	7,5
300	12	3,0	MR50	134	63	66	189	225	445	7,5
350	14	3,0	MR100	165	79	78	243	350	572	14
400	16	3,0	MR100	165	79	78	243	350	617	14
450	18	2,5	MR200	240	90	116	263	350	658	21,5
500	20	2,5	MR200	240	90	116	263	350	688	21,5
550	22	2,0	MR200	240	90	116	263	350	723	21,5
600	24	2,5	MR200	240	90	116	263	350	743	21,5
650	26	2,0	MR400	459	115	125	332	350	805	58
700	28	2,0	MR400	459	115	125	332	350	830	58
750	30	2,0	MR400	459	115	125	332	350	860	58
800	32	2,0	MR400	459	115	125	332	350	885	58
900	36	1,5	MR600	546	155	140	511	600	1074	105
1000	40	1,5	MR600	546	155	140	511	600	1144	105

Table 19: Actuation via MR manual gearbox for ISORIA 10 (with non-lubricating fluid, with any liner) [mm]

DN	NPS	Max. velocity	Type	B	C	D	E	H	h2	[kg] ¹²⁾
	[inch]	[m/s]								
40	1½	50	MR25	115	57	56	181	225	256	6
50	2	50	MR25	115	57	56	181	225	261	6
65	2½	50	MR25	115	57	56	181	225	287	6
80	3	50	MR25	115	57	56	181	225	293	6
100	4	50	MR25	115	57	56	181	225	314	6
125	5	50	MR25	115	57	56	181	225	328	6
150	6	50	MR25	115	57	56	181	225	345	6
200	8	50	MR25	115	57	56	181	225	373	6
250	10	50	MR50	134	63	66	189	225	418	7,5
300	12	50	MR50	134	63	66	189	225	445	7,5
350	14	50	MR100	165	79	78	243	350	572	14
400	16	50	MR100	165	79	78	243	350	617	14
450	18	50	MR200	240	90	116	263	350	658	21,5
500	20	50	MR200	240	90	116	263	350	688	21,5
550	22	50	MR200	240	90	116	263	350	723	21,5
600	24	50	MR200	240	90	116	263	350	743	21,5
650	26	50	MR400	459	115	125	332	350	805	58
700	28	50	MR400	459	115	125	332	350	830	58
750	30	50	MR400	459	115	125	332	350	860	58
800	32	50	MR400	459	115	125	332	350	885	58
900	36	50	MR600	546	155	140	511	600	1074	105
1000	40	50	MR600	546	155	140	511	600	1144	105

¹¹⁾ The weights given refer to the actuating element.

¹²⁾ The weights given refer to the actuating element.

Line connections

The valves can be installed between the following line connections (other line connections on request):

- EN 1092 PN 6 (ISORIA 10 only), 10 and 16
- ASME B16.1 Cl. 125 and B16.5 Cl. 150
- ASME B16.47 Cl. 150 Series A
- MSS SP 44 Cl.150
- AWWA C207 Cl. B, D and E
- AS 2129 Tables D and E
- BS 10 Tables D und E
- JIS B2220, B2238 and B2239 5K, 10K, 16K and 20K (ISORIA 16 only)

Table 20: Wafer-type body – T1

T1 wafer-type bodies can be installed between all the above-mentioned line connections.

Table 21: Semi-lug body (T2) for standards EN 1092, MSS SP44 Class 150, JIS B2220, JIS B2238 and JIS B2239

DN	NPS [inch]	EN 1092			MSS SP44 Class 150	JIS B2220, B2238, B2239			
		PN 6 ¹³⁾	PN 10	PN 16		5K	10K	16K	20K ¹⁴⁾
40	1½	✓	✓	✓	•	✓	✓	✓	✓
50	2	✓	✓	✓	•	✓	✓	✓■	✓■
65	2½	✓	✓	✓	•	✓	✓	✓■	✓■
80	3	✓	✓	✓	•	✓	✓	✓	✓
100	4	✓	✓	✓	•	✓	✓	✓	✓
125	5	✓	✓	✓	•	✓	✓	✓■	✓■
150	6	✓	✓	✓	•	✓	✓	✓■	✓■
200	8	✓	✓	✓	•	✓	✓	✓■	✓■
250	10	✓	✓	✓	•	✓	✓	✓■	✓■
300	12	✓	✓	✓	✓	✓	✓■	✓■	✓■
350	14	✓	✓	✓	✓	✓	✓	✓	✓
400	16	✓	✓	✓	✓	✓	✓	✓	✓
450	18	✓	✓	✓	✓	✓	✓	✓	✓
500	20	✓	✓	✓	✓	✓	✓	✓	✓
550	22	•	•	•	✓	✓	✓	✓	✓
600	24	✓	✓	✓	✓	✓	✓	✓	✓

Table 22: Semi-lug body (T2) for standards ASME, AWWA, BS10 and AS2129

DN	NPS [inch]	ASME		AWWA C207 B,D,E	BS10		AS2129	
		B16.1 Cl.125	B16.5 Cl.150		Table D	Table E	Table D	Table E
40	1½	✓	✓	•	✓	✓	✓	✓
50	2	✓	✓	•	✓	✓	✓	✓
65	2½	✓	✓	•	✓	✓	✓	✓
80	3	✓	✓	•	✓	✓	✓	✓
100	4	✓	✓	✓	✓■	✓	✓■	✓
125	5	✓	✓	✓	✓	✓	✓	✓
150	6	✓	✓	✓	✓	✓	✓	✓
200	8	✓	✓	✓	✓	✓	✓	✓
250	10	✓	✓	✓	✓■	✓	✓■	✓
300	12	✓	✓	✓	✓	✓	✓	✓
350	14	✓	✓	✓	✓	✓	✓	✓
400	16	✓	✓	✓	✓	✓	✓	✓
450	18	✓	✓	✓	✓	✓	✓	✓
500	20	✓	✓	✓	✓	✓	✓	✓
550	22	•	•	✓	✓	✓	✓	✓
600	24	✓	✓	✓	✓	✓	✓	✓

Table 23: Symbols key

Symbol	Description	Symbol	Description
✓	Installation possible	•	Non-standardised connection
■	Downstream dismantling not possible		

¹³ ISORIA 10-specific

¹⁴ ISORIA 16-specific

Table 24: Full-lug body with flat faces (T3) for standards EN 1092, MSS SP44 Class 150, JIS B2220, JIS B2238 and JIS B2239

DN	NPS [inch]	EN 1092			MSS SP44 cl.150	JIS B2220, B2238, B2239			
		PN 6	PN 10	PN 16		5K	10K	16K	20K
40	1½	☒	✓	✓	•	✓	✓	✓	☒
50	2	☒	✓	✓	•	✓	✓	✓	☒
65	2½	☒	✓	✓	•	✓	✓	✓	☒
80	3	☒	✓	✓	•	✓	✓	✓	☒
100	4	☒	✓	✓	•	✓	✓	✓	☒
125	5	☒	✓	✓	•	✓	✓	✓	☒
150	6	☒	✓	✓	•	✓	✓	♦	☒
200	8	☒	✓	✓	•	✓	✓	✓	☒
250	10	☒	✓	✓	•	✓	✓	✓	☒
300	12	☒	✓	✓	✓	✓	♦	✓	☒
350	14	☒	✓	✓	✓	✓	✓	✓	☒
400	16	☒	✓	✓	✓	✓	✓	✓	☒
450	18	☒	✓	✓	✓	✓	✓	✓	☒
500	20	☒	✓	✓	✓	✓	✓	✓	☒
550	22	☒	•	•	✓	✓	✓	✓	☒
600	24	☒	✓	✓	✓	✓	✓	✓	☒

Table 25: Full-lug body with flat faces (T3) for standards ASME, AWWA , BS10 and AS2129

DN	NPS [inch]	ASME		AWWA C207 B,D,E	BS10		AS2129	
		B16.1 Cl.125	B16.5 Cl.150		Table D	Table E	Table D	Table E
40	1½	✓	✓	•	☒	☒	☒	☒
50	2	✓	✓	•	☒	☒	☒	☒
65	2½	✓	✓	•	☒	☒	☒	☒
80	3	✓	✓	•	☒	☒	☒	☒
100	4	✓	✓	✓	☒	☒	☒	☒
125	5	✓	✓	✓	☒	☒	☒	☒
150	6	✓	✓	✓	☒	☒	☒	☒
200	8	✓	✓	✓	☒	☒	☒	☒
250	10	✓	✓	✓	☒	☒	☒	☒
300	12	✓	✓	✓	☒	☒	☒	☒
350	14	✓	✓	✓	☒	☒	☒	☒
400	16	✓	✓	✓	☒	☒	☒	☒
450	18	✓	✓	✓	☒	☒	☒	☒
500	20	✓	✓	✓	☒	☒	☒	☒
550	22	•	•	✓	☒	☒	☒	☒
600	24	✓	✓	✓	☒	☒	☒	☒

Table 26: Symbols key

Symbol	Description	Symbol	Description
✓	Installation possible	•	Non-standardised connection
☒	Contact KSB.	♦	Installation not possible

Table 27: Full-lug body with raised faces (T4) for standards EN 1092, MSS SP44 Class 150, JIS B2220, JIS B2238 and JIS B2239

DN	NPS [inch]	EN 1092			MSS SP44 cl.150	JIS B2220, B2238, B2239			
		PN 6	PN 10	PN 16		5K	10K	16K	20K
40	1½	✓	✓	✓	•	✓	✓	✓	✓
50	2	✓	✓	✓	•	✓	✓	♦	♦
65	2½	✓	✓	✓	•	✓	✓	♦	♦
80	3	✓	✓	✓	•	✓	✓	✓	✓
100	4	-	✓	✓	•	✓	✓	✓	✓
125	5	✓	✓	✓	•	✓	✓	♦	♦
150	6	✓	✓	✓	•	✓	✓	♦	♦
200	8	✓	✓	✓	•	✓	✓	♦	♦
250	10	✓	✓	✓	•	✓	✓	♦	♦
300	12	✓	✓	✓	✓	✓	♦	♦	♦
350	14	✓	✓	✓	✓	✓	✓	✓	✓
400	16	✓	✓	✓	✓	✓	✓	✓	✓
450	18	✓	✓	✓	✓	✓	✓	✓	✓
500	20	✓	✓	✓	✓	✓	✓	✓	✓
550	22	•	•	•	✓	✓	✓	✓	✓
600	24	✓	✓	✓	✓	✓	✓	✓	✓

Table 28: Full-lug body with raised faces (T4) for standards ASME, AWWA , BS10 and AS2129

DN	NPS [inch]	ASME		AWWA C207 B,D,E	BS10		AS2129	
		B16.1 Cl.125	B16.5 Cl.150		Table D	Table E	Table D	Table E
40	1½	✓	✓	•	✓	✓	✓	✓
50	2	✓	✓	•	✓	✓	✓	✓
65	2½	✓	✓	•	✓	✓	✓	✓
80	3	✓	✓	•	✓	✓	✓	✓
100	4	✓	✓	✓	♦	✓	♦	✓
125	5	✓	✓	✓	✓	✓	✓	✓
150	6	✓	✓	✓	✓	✓	✓	✓
200	8	✓	✓	✓	✓	✓	✓	✓
250	10	✓	✓	✓	♦	✓	♦	✓
300	12	✓	✓	✓	✓	✓	✓	✓
350	14	✓	✓	✓	✓	✓	✓	✓
400	16	✓	✓	✓	♦	♦	♦	♦
450	18	✓	✓	✓	♦	✓	♦	✓
500	20	✓	✓	✓	♦	♦	♦	♦
550	22	•	•	✓	♦	♦	♦	♦
600	24	✓	✓	✓	♦	♦	♦	♦

Table 29: Symbols key

Symbol	Description	Symbol	Description
✓	Installation possible	•	Non-standardised connection
⚙	Contact KSB.	♦	Installation not possible

Table 30: Flanged body with flat faces (T5) for standards EN 1092, MSS SP44 Class 150, JIS B2220, JIS B2238 and JIS B2239

DN	NPS	EN 1092			MSS SP44 cl.150	JIS B2220, B2238, B2239			
		PN 6	PN 10	PN 16		5K	10K	16K	20K
150	6	✓	✓	✓	•	✓	✓	✓	✓
200	8	✓	✓	✓	•	✓	✓	✓	✓
250	10	✓	✓	✓	•	✓	✓	✓■	✓■
300	12	✓	✓	✓	✓	✓	✓	✓	✓
350	14	✓	✓	✓	✓	✓	✓	✓	✓
400	16	✓	✓	✓	✓	✓	✓	✓	✓
450	18	✓	✓	✓	✓	✓	✓	♦	♦
500	20	✓	✓	✓	✓	✓	✓	✓	✓
550	22	•	•	•	✓	✓	✓	♦	♦
600	24	✓	✓	✓	✓	✓	✓	✓	✓
650	26	•	•	•	✓■	✓■	✓■	♦	⊗
700	28	✓■	✓■	✓■	✓■	✓■	✓■	♦	⊗
750	30	•	•	•	✓■	✓■	✓■	♦	⊗
800	32	✓■	✓■	✓■	✓■	✓■	✓■	♦	⊗
900	36	✓■	✓■	✓■	✓■	✓■	✓■	♦	♦
1000	40	✓■	✓■	✓■	✓■	✓■	✓■	♦	♦

Table 31: Flanged body with flat faces (T5) for standards ASME, AWWA , BS10 and AS2129

DN	NPS	ASME			AWWA C207 B,D,E	BS10		AS2129	
		B16.1 Cl. 125	B16.5 Cl. 150B16.1 Cl. 150	B16.47 Cl. 150		Table D	Table E	Table D	Table E
150	6	✓	✓	•	✓	✓	✓	✓	✓
200	8	✓	✓	•	✓	✓	✓	✓	✓
250	10	✓	✓	•	✓	♦	✓	♦	✓
300	12	✓	✓	•	✓	✓	✓	✓	✓
350	14	✓	✓	•	✓	✓	✓	✓	✓
400	16	✓	✓	•	✓	✓	✓	✓	✓
450	18	✓	✓	•	✓	✓	✓	✓	✓
500	20	✓	✓	•	✓	✓	✓	✓	✓
550	22	•	•	•	✓	✓	✓	✓	✓
600	24	✓	✓	•	✓	✓	✓	✓	✓
650	26	•	•	✓■	✓■	•	•	•	•
700	28	•	•	✓■	✓■	✓■	✓■	✓■	✓■
750	30	✓■	•	✓■	✓■	✓■	✓■	✓■	✓■
800	32	•	•	✓■	✓■	•	•	✓■	✓■
900	36	✓■	•	✓■	✓■	✓■	✓■	✓■	✓■
1000	40	•	•	✓■	✓■	✓■	✓■	✓■	✓■

Table 32: Symbols key

Symbol	Description	Symbol	Description
✓	Installation possible	•	Non-standardised connection
■	Downstream dismantling not possible	♦	Installation not possible
■	Flanged installation possible	⊗	Contact KSB.

Installation information

Dead-end service and downstream dismantling

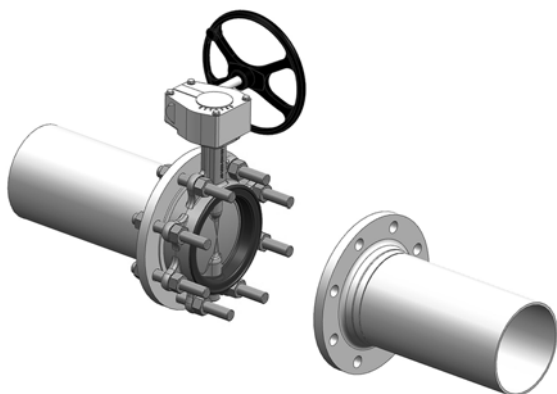

Downstream dismantling

For downstream dismantling,
successively loosen diagonally opposed tie bolts.

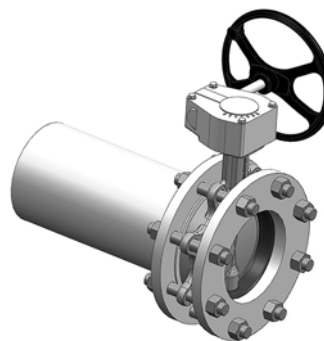

Dead-end service

Flange dimensions

The valves can be installed between all commercial mating flanges and line connections without requiring any flange gaskets.

The elastomer liner alone provides a tight seal at the flange connections.

The drawings below show a valve of body type T1 installed between flanges.

Please verify that the connection meets the requirements given below.

The flange dimensions indicated in the table apply to all body types.

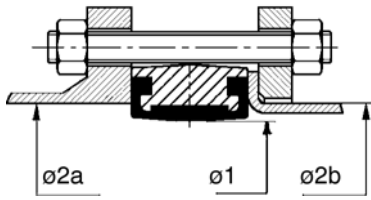

Drawing A

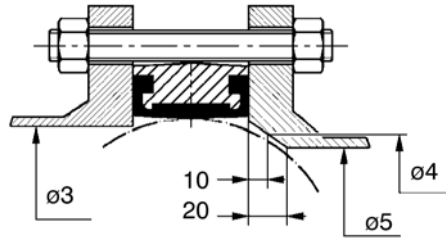

Drawing B

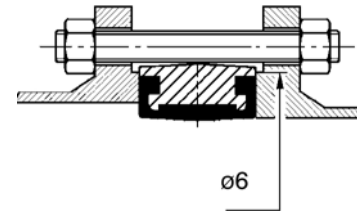

Drawing C

Ø2a and Ø3: flange face diameter

Ø2b: pipe OD with loose plate flange to DIN 2642 and NF E 29-251

Table 33: Dimensions table of ISORIA 10/16

DN	NPS	Optimum Ø	Max. permissible Ø		Min. permissible Ø of flange face	Min. Ø at a distance of 10 mm from the flange face	Min. Ø at a distance of 20 mm from the flange face	Min. permissible raised face Ø of flanges with raised faces
			Ø2a	Ø2b				
	[inch]	Ø1	Ø2a	Ø2b	Ø3	Ø4	Ø5	Ø6
40	1½	40	54	49	32	-	-	77
50	2	49	63	61	33	-	-	86
65	2½	65	80	77	55	13	-	107
80	3	77	93	89	71	50	-	121
100	4	96	116	115	90	74	40	141
125	5	123	141,5	140	119	107	87	171
150	6	146	170,5 ¹⁵⁾	169	144	134	120	196
200	8	196	222 ¹⁵⁾	220	196	189	178	250
250	10	249	276,5 ¹⁵⁾	273	249	243	234	306
300	12	298	327,5 ¹⁵⁾	324	297	291	283	358
350	14	330	361	356	326	321	314	399
400	16	380	412	407	370	366	358	452
450	18	430	463	457	422	416	409	505
500	20	480	515	508	470	464	457	558
550	22	540	568	561	522	516	509	625
600	24	580	617	610	566	560	554	664
650	26	630	668	-	620	614	608	723
700	28	680	718	-	671	666	660	773
750	30	730	770	-	717	711	705	830
800	32	780	820	-	769	764	758	880
900	36	880	924	-	869	864	859	987
1000	40	980	1027	-	970	965	960	1094

¹⁵ Verify that body is correctly centred between the tie bolts.

Coated flange

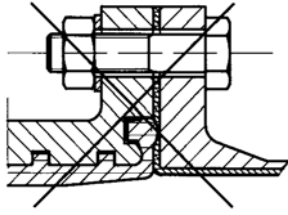

Flange with rubber coating

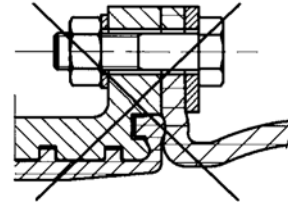

Expansion bellows

N.B.: Direct installation between rubber-coated flanges or with expansion bellows is not permitted. Contact us.

Installation between flanges made of polyethylene

- Installation between flanges with flat faces is permitted.
- Installation between flanges with grooved faces is not permitted.

Bolting and weights

Bolting and weights for wafer-type body - T1

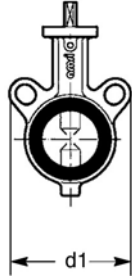

Drawing of ISORIA 10/16 T1 - DN 50

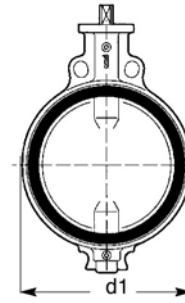

Drawing of ISORIA 10/16 T1 - DN 250

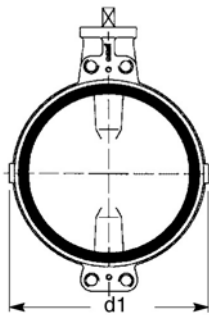

Drawing of ISORIA 10/16 T1 - DN 600

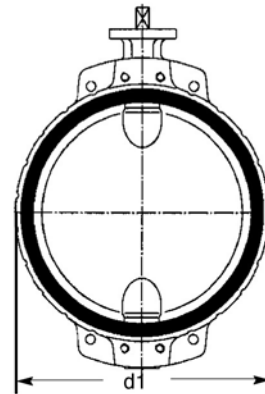

Drawing of ISORIA 10/16 T1 - DN 800

The drawings do not indicate the exact product design (number of tapped lugs/clearance holes).

N.B.: Bolting is not included in our standard scope of supply.

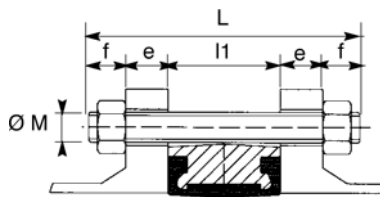

Length of tie bolt for wafer-type body - T1

$$L = l1 + 2e + 2f$$

- L: minimum length of tie bolts
- l1: face-to-face length of valve
- e: flange thickness (customer-specific)
- f: thickness of nut + standardised overhang of tie bolt

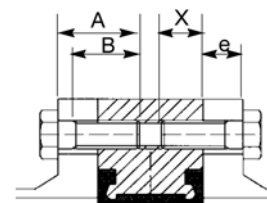

Length of bolt at shaft passage for wafer-type body - T1

$$A = e + X$$

- A: max. bolt length
- X: max. thread engagement depth
- e: flange thickness (customer-specific)
- B: min. thread length > A-e

Table 34: Dimensions [mm] and weights [kg] for wafer-type body T1 - connections EN 1092-1 PN 10 and PN 16

DN	NPS	l1	d1	EN 1092-1 PN 10					EN 1092-1 PN 16					[kg]
				Ø M	Tie bolt ¹⁶⁾		Bolt		Ø M	Tie bolt ¹⁶⁾		Bolt		
	[inch]				f	Qty	X	Qty ¹⁷⁾		f	Qty	X	Qty ¹⁷⁾	
40	1½	33	108	M16	20	4	-	-	M16	20	4	-	-	1,1
50	2	43	118	M16	20	4	-	-	M16	20	4	-	-	1,3
65	2½	46	133	M16	20	4/8	-	-	M16	20	4/8	-	-	1,9
80	3	46	138	M16	20	8	-	-	M16	20	8	-	-	2,5
100	4	52	144	M16	20	8	-	-	M16	20	8	-	-	3,9
125	5	56	174	M16	20	8	-	-	M16	20	8	-	-	4,7
150	6	56	198	M20	24	8	-	-	M20	24	8	-	-	6,9
200	8	60	252	M20	24	8	-	-	M20	24	12	-	-	10,5
250	10	68	310	M20	24	12	-	-	M24	29	12	-	-	16,4
300	12	78	362	M20	24	12	-	-	M24	29	12	-	-	30
350	14	78	433	M20	24	16	-	-	M24	29	16	-	-	50
400	16	102	490	M24	29	16	-	-	M27	32	16	-	-	72
450	18	114	546	M24	29	16	24	4	M27	32	16	27	4	96
500	20	127	600	M24	29	20	-	-	M30	35	20	-	-	130
550	22	154	645	¹⁸⁾	¹⁸⁾	¹⁸⁾	¹⁸⁾	¹⁸⁾	¹⁸⁾	¹⁸⁾	¹⁸⁾	¹⁸⁾	¹⁸⁾	-
600	24	154	714	M27	32	20	-	4	M33	38	20	-	-	190
650	26	165	745	¹⁸⁾	¹⁸⁾	¹⁸⁾	¹⁸⁾	¹⁸⁾	¹⁸⁾	¹⁸⁾	¹⁸⁾	¹⁸⁾	¹⁸⁾	-
700	28	165	795	M27	32	20	30	4	M33	38	20	25	4	315
750	30	190	853	¹⁸⁾	¹⁸⁾	¹⁸⁾	¹⁸⁾	¹⁸⁾	¹⁸⁾	¹⁸⁾	¹⁸⁾	¹⁸⁾	¹⁸⁾	-
800	32	190	903	M30	35	20	33	4	M36	42	20	36	4	475
900	36	203	1111	M30	35	24	33	4	M36	42	24	36	4	545
1000	40	216	1118	M33	38	24	36	4	M39	45	24	29	4	670

Table 35: Dimensions [mm] and weights [kg] for wafer-type body T1 - connections JIS B2220, B2238, B2239 10K and 16K

DN	NPS	l1	d1	JIS B2220, B2238, B2239 10K					JIS B2220, B2238, B2239 16K					[kg]
				Ø M	Tie bolts ¹⁶⁾		Bolt		Ø M	Tie bolt ¹⁶⁾		Bolt		
	[inch]				f	Qty	X	Qty ¹⁷⁾		f	Qty	X	Qty ¹⁷⁾	
40	1½	33	108	M16	20	4	-	-	M16	20	4	-	-	1,1
50	2	43	118	M16	20	4	-	-	M16	20	8	-	-	1,3
65	2½	46	133	M16	20	4	-	-	M16	20	8	-	-	1,9
80	3	46	138	M16	20	8	-	-	M20	24	8	-	-	2,5
100	4	52	144	M16	20	8	-	-	M20	24	8	-	-	3,9
125	5	56	174	M20	24	8	-	-	M22	26	8	-	-	4,7
150	6	56	198	M20	24	8	-	-	M22	26	12	-	-	6,9
200	8	60	252	M20	24	12	-	-	M22	26	12	-	-	10,5
250	10	68	310	M22	26	12	-	-	M24	29	12	-	-	16,4
300	12	78	362	M22	26	16	-	-	M24	29	12	-	-	30
350	14	78	433	M22	26	16	-	-	M30x3	35	16	-	-	50
400	16	102	490	M24	29	16	-	-	M30x3	35	16	-	-	72
450	18	114	546	M24	29	16	24	4	M30x3	35	16	30	4	96
500	20	127	600	M24	29	20	-	-	M30x3	35	20	-	-	130
550	22	154	645	M30	35	16	30	4	M36x3	42	16	36	4	160
600	24	154	714	M30	35	20	30	4	M36x3	42	20	36	4	190
650	26	165	745	M30	35	20	37	4	M36x3	42	20	34	4	270
700	28	165	795	M30	45	20	34	4	M39x3	45	20	34	4	315
750	30	190	853	M30	35	20	37	4	M39x3	45	20	34	4	380
800	32	190	903	M30	35	20	37	4	M45x3	50	20	35	4	475
900	36	203	1111	M30	35	24	37	4	-	-	-	-	-	545
1000	40	216	1118	M36	42	24	37	4	-	-	-	-	-	670

8445.5/05-EN

¹⁶ Quantity of nuts = quantity of tie rods x 2

¹⁷ Quantity of bolts x 2

¹⁸ Non-standardised connection

Table 36: Dimensions [mm] and weights [kg] for wafer-type body T1 - connections ASME and MSS SP 44 Class 150

DN	NPS	l1	d1	ASME B16.5 Class 150 ¹⁹⁾ ASME B16.1 Class 125 ¹⁹⁾ MSS SP 44 Class 150 ¹⁹⁾ ASME B16.47 Class 150 Series A ¹⁹⁾					[kg]
				UNC	Tie bolt ¹⁶⁾		Bolt		
	[inch]			[inch]	f	Qty	X	Qty ¹⁷⁾	
40	1½	33	108	1/2	17	4	-	-	1,1
50	2	43	118	5/8	20	4	-	-	1,3
65	2½	46	133	5/8	20	4	-	-	1,9
80	3	46	138	5/8	20	4	-	-	2,5
100	4	52	144	5/8	20	8	-	-	3,9
125	5	56	174	3/4	24	8	-	-	4,7
150	6	56	198	3/4	24	8	-	-	6,9
200	8	60	252	3/4	24	8	-	-	10,5
250	10	68	310	7/8	29	12	-	-	16,4
300	12	78	362	7/8	29	12	-	-	30
350	14	78	433	1	32	12	-	-	50
400	16	102	490	1	32	16	-	-	72
450	18	114	546	1 1/8	35	16	-	-	96
500	20	127	600	1 1/8	35	16	30	4	130
550	22	154	645	1 1/4	38	16	33	4	160
600	24	154	714	1 1/4	38	20	-	-	190
650	26	165	745	1 1/4	38	20	25	4	270
700	28	165	795	1 1/4	38	24	25	4	315
750	30	190	853	1 1/4	38	24	33	4	380
800	32	190	903	1 1/2	45	24	29	4	475
900	36	203	1111	1 1/2	45	28	29	4	545
1000	40	216	1118	1 1/2	45	32	35	4	670

¹⁹⁾ For DN's concerned, see connection standards.

Bolting and weights for semi-lug body - T2



Drawing of ISORIA 10/16 T2 – DN 65

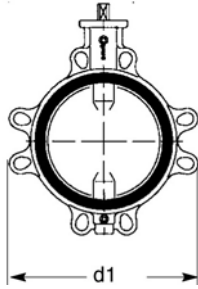

Drawing of ISORIA 10/16 T2 – DN 250

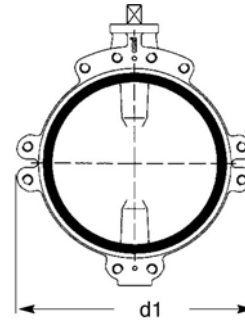

Drawing of ISORIA 10/16 T2 – DN 600

The drawings do not indicate the exact product design (number of tapped lugs/clearance holes).

N.B.: Bolting is not included in our standard scope of supply.

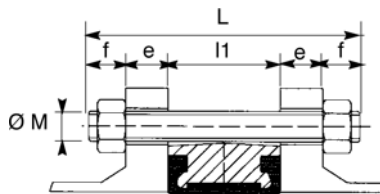

Length of tie bolt for semi-lug body – T2

$$L = l1 + 2e + 2f$$

- L: minimum length of tie bolts
- l1: face-to-face length of valve
- e: flange thickness (customer-specific)
- f: thickness of nut + standardised overhang of tie bolt

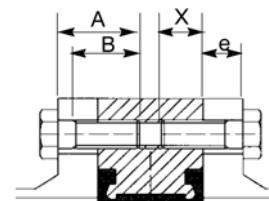

Length of bolt at shaft passage for semi-lug body – T2

$$A = e + X$$

- A: max. bolt length
- X: max. thread engagement depth
- e: flange thickness (customer-specific)
- B: min. thread length > A-e

Table 37: Dimensions [mm] and weights [kg] for semi-lug body T2 – connections EN 1092-1 PN 10 and PN 16

DN	NPS	l1	d1	EN 1092-1 PN 10					EN 1092-1 PN 16					[kg]
				Ø M	Tie bolt ²⁰⁾		Bolt		Ø M	Tie bolt ²⁰⁾		Bolt		
	[inch]				f	Qty	X	Qty ²¹⁾		f	Qty	X	Qty ²¹⁾	
40	1½	33	108	M16	20	4	-	-	M16	20	4	-	-	1,1
50	2	43	118	M16	20	4	-	-	M16	20	4	-	-	1,3
65	2½	46	132	M16	20	4/8	-	-	M16	20	4/8	-	-	1,9
80	3	46	138	M16	20	8	-	-	M16	20	8	-	-	2,5
100	4	52	150	M16	20	8	-	-	M16	20	8	-	-	3,9
125	5	56	234	M16	20	8	-	-	M16	20	8	-	-	4,7
150	6	56	260	M20	24	8	-	-	M20	24	8	-	-	6,9
200	8	60	322	M20	24	8	-	-	M20	24	12	-	-	10,5
250	10	68	394	M20	24	12	-	-	M24	29	12	-	-	16,4
300	12	78	462	M20	24	12	-	-	M24	29	12	-	-	30
350	14	78	538	M20	24	10	20	6	M24	29	10	24	6	60
400	16	102	604	M24	29	10	24	6	M27	32	10	27	6	80
450	18	114	656	M24	29	14	24	6	M27	32	14	27	6	110
500	20	127	716	M24	29	12	24	8	M30	35	12	30	8	145
550	22	154	804	22)	22)	22)	22)	22)	22)	22)	22)	22)	22)	22)
600	24	154	836	M27	32	10	27	10	M33	38	10	33	10	220

Table 38: Dimensions [mm] and weights [kg] for semi-lug body T2 – connections JIS B2220, B2238, B2239 10K and 16K

DN	NPS	l1	d1	JIS B2220, B2238, B2239 10K					JIS B2220, B2238, B2239 16K					[kg]
				Ø M	Tie bolt ²⁰⁾		Bolt		Ø M	Tie bolt ²⁰⁾		Bolt		
	[inch]				f	Qty	X	Qty ²¹⁾		f	Qty	X	Qty ²¹⁾	
40	1½	33	108	M16	20	4	-	-	M16	20	4	-	-	1,1
50	2	43	118	M16	20	4	-	-	M16	20	8	-	-	1,3
65	2½	46	132	M16	20	4	-	-	M16	20	8	-	-	1,9
80	3	46	138	M16	20	8	-	-	M20	24	8	-	-	2,5
100	4	52	150	M16	20	8	-	-	M20	24	8	-	-	3,9
125	5	56	234	M20	24	8	-	-	M22	26	8	-	-	4,7
150	6	56	260	M20	24	8	-	-	M22	26	12	-	-	6,9
200	8	60	322	M20	24	12	-	-	M22	26	12	-	-	10,5
250	10	68	394	M22	26	12	-	-	M24	29	12	-	-	16,4
300	12	78	462	M22	26	16	-	-	M24	29	12	-	-	30
350	14	78	538	M22	26	10	22	6	M30 x 3	35	10	30	6	60
400	16	102	604	M24	29	10	24	6	M30 x 3	35	16	30	6	80
450	18	114	656	M24	29	12	24	6	M30 x 3	35	14	30	6	110
500	20	127	716	M24	29	12	24	8	M30 x 3	35	12	30	8	145
550	22	154	804	M24	35	12	30	8	M36 x 3	42	12	36	8	180
600	24	154	836	M30	35	14	30	10	M36x3	42	14	36	10	220

²⁰ Quantity of nuts = quantity of tie bolts x 2

²¹ Quantity of bolts x 2

²² Non-standardised connection

Table 39: Dimensions [mm] and weights [kg] for semi-lug body T2 – connections ASME and MSS SP 44 Class 150

DN	NPS	l1	d1	ASME B16.5 Class 150 ²³⁾ ASME B16.1 Class 125 ²³⁾ MSS SP 44 Cl. 150 ²³⁾ ASME B16.47 Cl. 150 Series A ²³⁾					[kg]
				UNC	Tie bolt ²⁰⁾		Bolt		
	[inch]			[inch]	f	Qty	X	Qty ²¹⁾	
40	1½	33	108	1/2	17	4	-	-	1,1
50	2	43	118	5/8	20	4	-	-	1,3
65	2½	46	132	5/8	20	4	-	-	1,9
80	3	46	138	5/8	20	4	-	-	2,5
100	4	52	150	5/8	20	8	-	-	3,9
125	5	56	234	3/4	24	8	-	-	4,7
150	6	56	260	3/4	24	8	-	-	6,9
200	8	60	322	3/4	24	8	-	-	10,5
250	10	68	394	7/8	29	12	-	-	16,4
300	12	78	462	7/8	29	12	-	-	30
350	14	78	538	1	32	6	27	6	60
400	16	102	604	1	32	10	27	6	80
450	18	114	656	1 1/8	35	10	30	6	110
500	20	127	716	1 1/8	35	12	30	8	145
550	22	154	804	1 1/4	38	12	32	8	180
600	24	154	836	1 1/4	38	10	32	10	220

²³⁾ For DN's concerned, see connection standards.

Bolting and weights for full-lug body with flat faces - T3

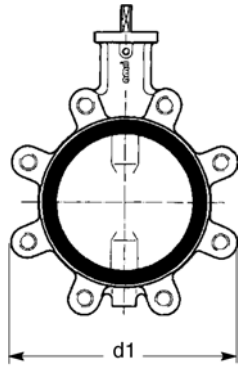

Drawing of ISORIA 10/16 T3 - DN 150

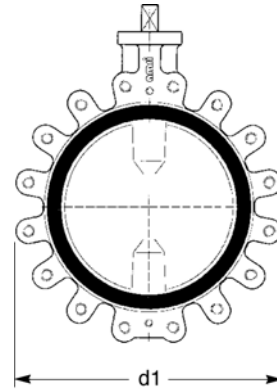

Drawing of ISORIA 10/16 T3 - DN 600

The drawings do not indicate the exact product design (number of lugs).

N.B.: Bolting is not included in our standard scope of supply.

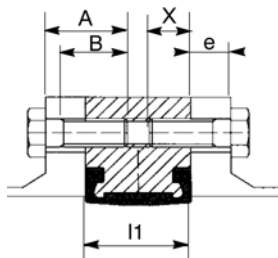

$$A = e + X$$

- A: max. bolt length
- X: max. thread engagement depth
- e: flange thickness (customer-specific)
- B: min. thread length > A-e
- l1: face-to-face length of valve

Length of bolts for full-lug body with flat faces - T3

Table 40: Dimensions [mm] and weights [kg] for full-lug body with flat faces T3 - connections EN 1092-1, PN 10 and PN 16

DN	NPS [inch]	l1	d1	EN 1092-1 PN 10				EN 1092-1 PN 16				[kg]		
				Ø M	Tie bolts ²⁴⁾		Bolt		Ø M	Tie bolts ²⁴⁾			Bolt	
					f	Qty	X	Qty ²⁵⁾		f	Qty		X	Qty ²⁵⁾
40	1½	33	108	M16	-	-	14	4	M16	-	-	14	4	2
50	2	43	120	M16	-	-	18	4	M16	-	-	18	4	2,5
65	2½	46	134	M16	-	-	20	4/8	M16	-	-	20	4/8	3
80	3	46	140	-	-	-	-	-	-	-	-	-	-	4
80	3	46	178	M16	-	-	20	8	M16	-	-	20	8	4,5
100	4	52	210	M16	-	-	22	8	M16	-	-	22	8	5,5
125	5	56	236	M16	-	-	22	8	M16	-	-	22	8	9
150	6	56	260	M20	-	-	26	8	M20	-	-	26	8	11
200	8	60	312	M20	-	-	26	8	-	-	-	-	-	24
200	8	60	322	-	-	-	-	-	M20	-	-	26	12	25
250	10	68	396	M20	-	-	26	12	M24	-	-	29	12	39
300	12	78	466	M20	-	-	26	12	M24	-	-	30	12	46
350	14	78	510	-	-	-	-	-	-	-	-	-	-	62
350	14	78	530	M20	-	-	26	16	M24	-	-	30	16	70
400	16	102	598	M24	-	-	31	16	M27	-	-	34	16	101
450	18	114	622	²⁶⁾	-	-	²⁶⁾	²⁶⁾	²⁶⁾	-	-	²⁶⁾	²⁶⁾	122
450	18	114	654	M24	-	-	31	20	M27	-	-	34	20	139
500	20	127	708	M24	-	-	24	8	M30	-	-	30	8	145
550	22	154	774	²⁶⁾	-	-	²⁶⁾	²⁶⁾	²⁶⁾	-	-	²⁶⁾	²⁶⁾	179
600	24	154	822	M27	-	-	27	10	M33	-	-	33	10	233
600	24	154	830	²⁶⁾	-	-	²⁶⁾	²⁶⁾	²⁶⁾	-	-	²⁶⁾	²⁶⁾	233

Table 41: Dimensions [mm] and weights [kg] for full-lug body with flat faces T3 - connections JIS B2220, B2238, B2239 10K and 16K

DN	NPS [inch]	l1	d1	JIS B2220, B2238, B2239 10K				JIS B2220, B2238, B2239 16K				[kg]		
				Ø M	Tie bolts ²⁴⁾		Bolt		Ø M	Tie bolt ²⁴⁾			Bolt	
					f	Qty	X	Qty ²⁵⁾		f	Qty		X	Qty ²⁵⁾
40	1½	33	108	M16	-	-	14	4	M16	-	-	14	4	2
50	2	43	120	M16	-	-	18	4	²⁶⁾	-	-	²⁶⁾	²⁶⁾	2,5
65	2½	46	134	M16	-	-	20	4	²⁶⁾	-	-	²⁶⁾	²⁶⁾	3
80	3	46	140	²⁶⁾	-	-	²⁶⁾	²⁶⁾	-	-	-	-	-	4
80	3	46	178	M16	-	-	20	8	M20	-	-	20	8	4,5
100	4	52	210	M16	-	-	22	8	M20	-	-	24	8	5,5
125	5	56	236	M20	-	-	23	8	²⁶⁾	-	-	²⁶⁾	²⁶⁾	9
150	6	56	260	M20	-	-	26	8	²⁶⁾	-	-	²⁶⁾	²⁶⁾	11
200	8	60	312	²⁶⁾	-	-	²⁶⁾	²⁶⁾	²⁶⁾	-	-	²⁶⁾	²⁶⁾	24
200	8	60	322	M20	-	-	26	12	²⁶⁾	-	-	²⁶⁾	²⁶⁾	25
250	10	68	396	M22	-	-	28	12	²⁶⁾	-	-	²⁶⁾	²⁶⁾	39
300	12	78	466	²⁶⁾	-	-	²⁶⁾	²⁶⁾	M24	-	-	30	16	46
350	14	78	510	²⁶⁾	-	-	²⁶⁾	²⁶⁾	-	-	-	-	-	62
350	14	78	530	M22	-	-	28	16	M30x3	-	-	34	16	70
400	16	102	598	M24	-	-	31	16	M30x3	-	-	37	16	101
450	18	114	622	²⁶⁾	-	-	²⁶⁾	²⁶⁾	-	-	-	-	-	122
450	18	114	654	M27	-	-	34	20	M30x3	-	-	37	20	139
500	20	127	708	M27	-	-	34	20	M30x3	-	-	37	20	145
550	22	154	774	M27	-	-	34	20	M30x3	-	-	42	20	179
600	24	154	822	²⁶⁾	-	-	²⁶⁾	²⁶⁾	-	-	-	-	-	233
600	24	154	830	M30	-	-	32	24	M36x3	-	-	34	24	233

8445.5 /05-EN

²⁴⁾ Quantity of nuts = quantity of tie rods x 2

²⁵⁾ Quantity of bolts x 2

²⁶⁾ Non-standardised connection

Table 42: Dimensions [mm] and weights [kg] for full-lug body with flat faces T3 - connections ASME and MSS SP 44 Class 150

DN	NPS	l1	d1	ASME B16.5 Class 150 ²⁷⁾ ASME B16.1 Class 125 ²⁷⁾ MSS SP 44 Class 150 ²⁷⁾ ASME B16.47 Class 150 Series A ²⁷⁾					[kg]
				UNC	Tie bolt ²⁴⁾		Bolt		
	[inch]			[inch]	f	Qty	X	Qty ²⁵⁾	
40	1½	33	108	1/2	-	-	14	4	2
50	2	43	120	5/8	-	-	18	4	2,5
65	2½	46	134	5/8	-	-	20	4	3
80	3	46	140	5/8	-	-	20	4	4
80	3	46	178	²⁶⁾	-	-	²⁶⁾	²⁶⁾	4,5
100	4	52	210	5/8	-	-	22	8	5,5
125	5	56	236	3/4	-	-	23	8	9
150	6	56	260	3/4	-	-	26	8	11
200	8	60	312	3/4	-	-	26	8	24
200	8	60	322	²⁶⁾	-	-	²⁶⁾	²⁶⁾	25
250	10	68	396	7/8	-	-	28	12	39
300	12	78	466	7/8	-	-	28	12	46
350	14	78	510	1	-	-	30	12	62
350	14	78	530	²⁶⁾	-	-	²⁶⁾	²⁶⁾	70
400	16	102	598	1	-	-	34	16	101
450	18	114	622	1 1/8	-	-	37	16	122
450	18	114	654	²⁶⁾	-	-	²⁶⁾	²⁶⁾	139
500	20	127	708	1 1/8	-	-	37	20	145
550	22	154	774	1 1/4	-	-	39	20	179
600	24	154	822	1 1/4	-	-	42	20	233
600	24	154	830	²⁶⁾	-	-	²⁶⁾	²⁶⁾	233

²⁷⁾ For DN's concerned, see connection standards.

Bolting and weights for full-lug body with raised faces - T4

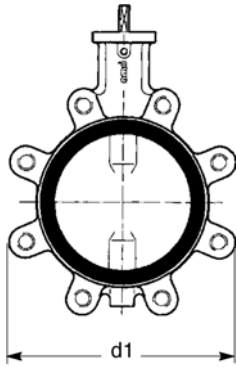

Drawing of ISORIA 10/16 T4 – DN 150

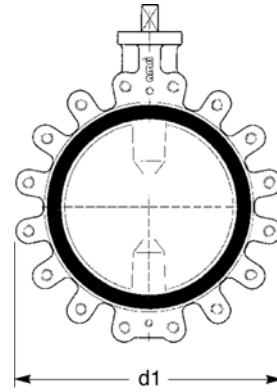

Drawing of ISORIA 10/16 T4 – DN 600

The drawings do not indicate the exact product design (number of lugs).

N.B.: Bolting is not included in our standard scope of supply.

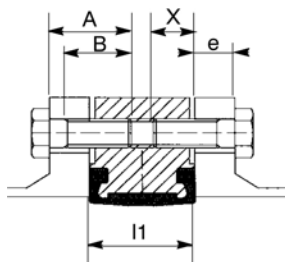

$$A = e + X$$

- A: max. bolt length
- X: max. thread engagement depth
- e: flange thickness (customer-specific)
- B: min. thread length > A-e

Length of bolts for full-lug body with raised faces – T4

Table 43: Dimensions [mm] and weights [kg] for full-lug body with raised faces T4 – connections EN 1092-1, PN 10 and PN 16

DN	NPS [inch]	l1	d1	EN 1092-1 PN 10					EN 1092-1 PN 16					[kg]
				Ø M	Tie bolt ²⁸⁾		Bolt		Ø M	Tie bolt ²⁸⁾		Bolt		
					f	Qty	X	Qty ²⁹⁾		f	Qty	X	Qty ²⁹⁾	
40	1½	33	108	M16	-	-	14	4	M16	-	-	14	4	2
50	2	43	120	M16	-	-	18	4	M16	-	-	18	4	2,5
65	2½	46	134	M16	-	-	-	-	M16	-	-	20	4	3
80 ³⁰⁾	3	46	140	-	-	-	-	-	-	-	-	-	-	4
31)80	3	46	178	M16	-	-	20	8	M16	-	-	20	8	4,5
100	4	52	210	M16	-	-	22	8	M16	-	-	22	8	5,5
125	5	56	236	M16	-	-	22	8	M16	-	-	22	8	9
150	6	56	260	M20	-	-	26	8	M20	-	-	26	8	11
200 ³²⁾	8	60	312	M20	-	-	26	8	-	-	-	-	-	24
200 ³³⁾	8	60	322	-	-	-	-	-	M20	-	-	26	12	25
250	10	68	396	M20	-	-	26	12	M24	-	-	29	12	39
300	12	78	466	M20	-	-	26	12	M24	-	-	30	12	46
350 ³⁰⁾	14	78	510	-	-	-	-	-	-	-	-	-	-	62
350 ³¹⁾	14	78	530	M20	-	-	26	16	M24	-	-	30	16	70
400	16	102	598	M24	-	-	31	16	M27	-	-	34	16	101
450 ³⁰⁾	18	114	622	³⁴⁾	-	-	³⁴⁾	³⁴⁾	³⁴⁾	-	-	³⁴⁾	³⁴⁾	122
450 ³¹⁾	18	114	654	M24	-	-	31	20	M27	-	-	34	20	139
500	20	127	708	M24	-	-	24	8	M30	-	-	30	8	145
550	22	154	774	³⁴⁾	-	-	³⁴⁾	³⁴⁾	³⁴⁾	-	-	³⁴⁾	³⁴⁾	179
600 ³⁵⁾	24	154	822	M27	-	-	27	10	M33	-	-	33	10	233
600 ³⁶⁾	24	154	830	-	-	-	-	-	-	-	-	-	-	233

Table 44: Dimensions [mm] and weights [kg] for full-lug body with raised faces T4 – connections JIS B2220, B2238, B2239 10K and 16K

DN	NPS [inch]	l1	d1	JIS B2220, B2238, B2239 10K					JIS B2220, B2238, B2239 16K					[kg]
				Ø M	Tie bolt ²⁸⁾		Bolt		Ø M	Tie bolt ²⁸⁾		Bolt		
					f	Qty	X	Qty ²⁹⁾		f	Qty	X	Qty ²⁹⁾	
40	1½	33	108	M16	-	-	14	4	M16	-	-	14	4	2
50	2	43	120	M16	-	-	18	4	³⁴⁾	-	-	³⁴⁾	³⁴⁾	2,5
65	2½	46	134	M16	-	-	20	4	³⁴⁾	-	-	³⁴⁾	³⁴⁾	3
80 ³⁰⁾	3	46	140	-	-	-	-	-	-	-	-	-	-	4
80 ³¹⁾	3	46	178	M16	-	-	20	8	M20	-	-	20	8	4,5
100	4	52	210	M16	-	-	22	8	M20	-	-	24	8	5,5
125	5	56	236	M20	-	-	23	8	³⁴⁾	-	-	³⁴⁾	³⁴⁾	9
150	6	56	260	M20	-	-	26	8	³⁴⁾	-	-	³⁴⁾	³⁴⁾	11
200 ³²⁾	8	60	312	-	-	-	-	-	³⁴⁾	-	-	³⁴⁾	³⁴⁾	24
200 ³³⁾	8	60	322	M20	-	-	26	12	³⁴⁾	-	-	³⁴⁾	³⁴⁾	25
250	10	68	396	M22	-	-	28	12	³⁴⁾	-	-	³⁴⁾	³⁴⁾	39
300	12	78	466	³⁴⁾	-	-	³⁴⁾	³⁴⁾	M24	-	-	30	16	46
350 ³⁰⁾	14	78	510	-	-	-	-	-	-	-	-	-	-	62
350 ³¹⁾	14	78	530	M22	-	-	28	16	M30x3	-	-	34	16	70

²⁸ Quantity of nuts = quantity of tie bolts x 2

²⁹ Quantity of bolts x 2

³⁰ Installation between flanges EN 1092 PN 6, ASME B16.5 Cl. 150, JIS B2220, B2238 and B2239-5K, BS 10 Tables D and E and AS 2129 Tables D and E

³¹ Installation between flanges EN 1092 PN 10, PN 16 and JIS B2220, B2238 and B2239 - 10K and 16K

³² Installation between flanges EN 1092 PN 6 and 10, ASME B16.5 Cl. 150, AWWA C 207 B, D and E, BS 10 Tables D and E, AS 2129 Tables D and E and JIS B2220, B2238 and B2239-5K

³³ Installation between flanges EN 1092 PN 16 and JIS B2220, B2238 and B2239-10K

³⁴ Non-standardised connection

³⁵ Installation between flanges EN 1092 PN 10, PN 16, ASME B16.5 Cl. 150 and JIS B2220, B2238 and B2239-5K

³⁶ Installation between flanges JIS B2220, B2238 and B2239-10K

DN	NPS [inch]	I1	d1	JIS B2220, B2238, B2239					JIS B2220, B2238, B2239					[kg]
				10K					16K					
				Ø M	Tie bolt ²⁸⁾		Bolt		Ø M	Tie bolt ²⁸⁾		Bolt		
	f	Qty	X	Qty ²⁹⁾		f	Qty	X	Qty ²⁹⁾					
400	16	102	598	M24	-	-	31	16	M30x3	-	-	37	16	101
450 ³⁰⁾	18	114	622	³⁴⁾	-	-	³⁴⁾	³⁴⁾	-	-	-	-	-	122
450 ³¹⁾	18	114	654	M27	-	-	34	20	M30x3	-	-	37	20	139
500	20	127	708	M27	-	-	34	20	M30x3	-	-	37	20	145
550	22	154	774	M27	-	-	34	20	M36x3	-	-	42	20	179
600 ³⁵⁾	24	154	822	-	-	-	-	-	-	-	-	-	-	233
600 ³⁶⁾	24	154	830	M30	-	-	32	24	M36x3	-	-	34	24	233

Table 45: Dimensions [mm] and weights [kg] for full-lug body with raised faces T4 – connections ASME and MSS SP 44 Class 150

DN	NPS [inch]	I1	d1	ASME B16.5 Class 150 ³⁷⁾ ASME B16.1 Class 125 ³⁷⁾ MSS SP 44 Cl. 150 ³⁷⁾ ASME B16.47 Cl. 150 Series A ³⁷⁾					[kg]
				UNC	Tie bolt ²⁸⁾		Bolt		
				[inch]	f	Qty	X	Qty ²⁹⁾	
40	1½	33	108	1/2	-	-	14	4	2
50	2	43	120	5/8	-	-	18	4	2,5
65	2½	46	134	5/8	-	-	20	4	3
80 ³⁰⁾	3	46	140	5/8	-	-	20	4	4
80 ³¹⁾	3	46	178	-	-	-	-	-	4,5
100	4	52	210	5/8	-	-	22	8	5,5
125	5	56	236	3/4	-	-	23	8	9
150	6	56	260	3/4	-	-	26	8	11
200 ³²⁾	8	60	312	3/4	-	-	26	8	24
200 ³³⁾	8	60	322	-	-	-	-	-	25
250	10	68	396	7/8	-	-	28	12	39
300	12	78	466	7/8	-	-	28	12	46
350 ³⁰⁾	14	78	510	1	-	-	30	12	62
350 ³¹⁾	14	78	530	³⁴⁾	-	-	³⁴⁾	³⁴⁾	70
400	16	102	598	1	-	-	34	16	101
450 ³⁰⁾	18	114	622	1 1/8	-	-	37	16	122
450 ³¹⁾	18	114	654	³⁴⁾	-	-	³⁴⁾	³⁴⁾	139
500	20	127	708	1 1/8	-	-	37	20	145
550	22	154	774	1 1/4	-	-	39	20	179
600 ³⁵⁾	24	154	822	1 1/4	-	-	42	20	233
600 ³⁶⁾	24	154	830	-	-	-	-	-	233

³⁷⁾ For DN's concerned, see connection standards.

Bolting and weights for flanged body with flat faces - T5 DN 150 - 600

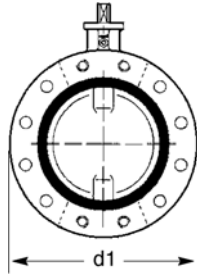

Drawing of ISORIA 10/16 T5 – DN 250

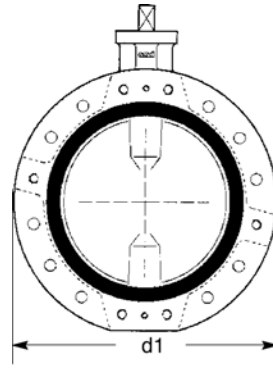

Drawing of ISORIA 10/16 T5 – DN 400

The drawings do not indicate the exact product design
(number of tapped holes/plain holes)

N.B.: Bolting is not included in our standard scope of supply.

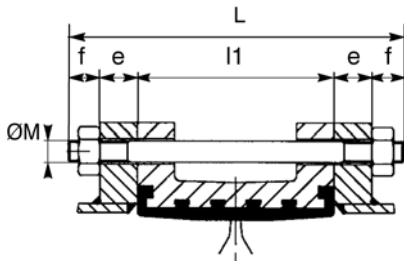

Length of tie bolt for flanged body with flat faces
– T5

$$L = l1 + 2e + 2f$$

- L: minimum length of tie bolt
- l1: face-to-face length of valve
- e: flange thickness (customer-specific)
- f: thickness of nut + standardised overhang of tie bolt

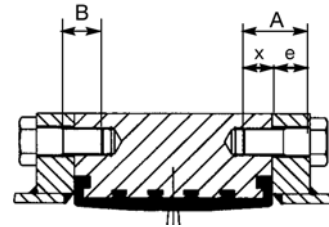

Length of bolt at shaft passage for flanged body with flat faces
– T5

$$A = e + X$$

- A: max. bolt length
- X: max. thread engagement depth
- e: flange thickness (customer-specific)
- B: min. thread length > A-e

Table 46: Dimensions [mm] and weights [kg] for flanged body with flat faces T5 – connections EN 1092-1, PN 10 and PN 16

DN	NPS	l1	d1	EN 1092-1 PN 10					EN 1092-1 PN 16					[kg]
				Ø M	Tie bolt ³⁸⁾		Bolt		Ø M	Tie bolt ³⁸⁾		Bolt		
	[inch]				f	Qty	X	Qty ³⁹⁾		f	Qty	X	Qty ³⁹⁾	
150	6	56	260	M20	24	4	20	4	M20	24	4	16	4	11
200	8	60	322	M20	24	4	20	4	M20	24	8	16	4	23
250	10	68	394	M20	24	8	20	4	M24	29	8	24	4	40
300	12	78	462	M20	24	6	20	6	M24	29	6	24	6	60
350	14	78	538	M20	24	10	20	6	M24	29	10	24	6	80
400	16	102	604	M24	29	10	24	6	M27	32	10	27	6	105
450	18	114	656	M24	29	14	24	6	M27	32	14	27	6	130
500	20	127	716	M24	29	12	24	8	M30	35	12	30	8	180
550	22	154	804	40)	40)	40)	40)	40)	40)	40)	40)	40)	40)	40)
600	24	154	836	M27	32	10	27	10	M33	38	10	33	10	260

Table 47: Dimensions [mm] and weights [kg] for flanged body with flat faces T5 – connections JIS B2220, B2238, B2239 10K and 16K

DN	NPS	l1	d1	JIS B2220, B2238, B2239 10K					JIS B2220, B2238, B2239 16K					[kg]
				Ø M	Tie bolt ³⁸⁾		Bolt		Ø M	Tie bolt ³⁸⁾		Bolt		
	[inch]				f	Qty	X	Qty ³⁹⁾		f	Qty	X	Qty ³⁹⁾	
150	6	56	260	M20	24	4	20	4	M22	26	8	22	4	11
200	8	60	322	M20	24	8	20	4	M22	26	8	22	4	23
250	10	68	394	M22	26	8	22	4	M24	29	8	24	4	40
300	12	78	462	M22	26	10	22	6	M24	29	10	24	6	60
350	14	78	538	M22	26	10	22	6	M30x3	35	10	30	6	80
400	16	102	604	M24	29	10	24	6	M30x3	35	10	30	6	105
450	18	114	656	M24	29	12	24	6	-	-	-	-	-	130
500	20	127	716	M24	29	12	24	8	M30x3	35	12	30	8	180
550	22	154	804	M30	35	12	30	8	-	-	-	-	-	230
600	24	154	836	M30	35	14	30	10	M30x3	42	14	36	10	260

Table 48: Dimensions [mm] and weights [kg] for flanged body with flat faces T5 – connections ASME and MSS SP 44 Class 150

DN	NPS	l1	d1	ASME B16.5 Class 150 ⁴¹⁾ ASME B16.1 Class 125 ⁴¹⁾ MSS SP 44 Cl. 150 ⁴¹⁾ ASME B16.47 Cl. 150 Series A ⁴¹⁾					[kg]
				UNC	Tie bolt ³⁸⁾		Bolt		
	[inch]				f	Qty	X	Qty ³⁹⁾	
150	6	56	260	3/4	24	4	20	4	11
200	8	60	322	3/4	24	4	20	4	23
250	10	68	394	7/8	29	8	24	4	40
300	12	78	462	7/8	29	6	24	6	60
350	14	78	538	1	32	6	27	6	80
400	16	102	604	1	32	10	27	6	105
450	18	114	656	1 1/8	35	10	30	6	130
500	20	127	716	1 1/8	35	12	30	8	180
550	22	154	804	1 1/4	38	12	32	8	230
600	24	154	836	1 1/4	38	10	32	10	260

³⁸ Quantity of nuts = quantity of tie bolts x 2
³⁹ Quantity of bolts x 2
⁴⁰ Non-standardised connection
⁴¹ For DN's concerned, see connection standards.

Bolting and weights for flanged body with flat faces - T5 DN 650 - 600

Flanged installation is permitted up to a max. differential pressure of 10 bar.

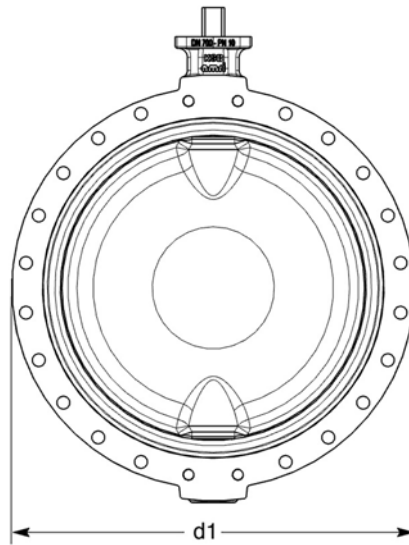

Drawing of ISORIA 10/16 T5 – DN 700

The drawings do not indicate the exact product design (number of tapped holes/clearance holes).

N.B.: Bolting is not included in our standard scope of supply.

Installation between flanges

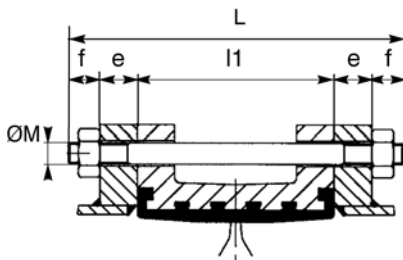

Length of tie bolt for flanged body with flat faces – T5

$$L = l1 + 2e + 2f$$

- L: minimum length of tie bolts
- l1: face-to-face length of valve
- e: flange thickness (customer-specific)
- f: thickness of nut + standardised overhang of tie bolt

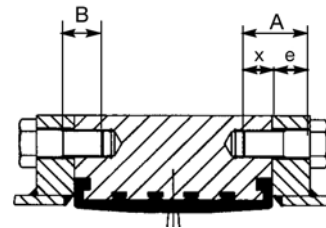

Length of bolt at shaft passage for flanged body with flat faces – T5

$$A = e + X$$

- A: max. bolt length
- X: max. thread engagement depth
- e: flange thickness (customer-specific)
- B: min. thread length > A-e
- C: flange thickness

Flanged installation

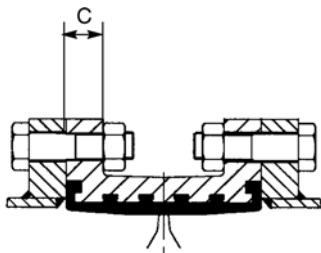

Length of bolts for flanged body with flat faces – T5

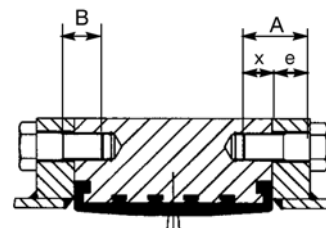

Length of bolt at shaft passage for flanged body with flat faces – T5

Information on fasteners available on request

Table 49: Dimensions [mm] and weights [kg] for flanged body with flat faces T5 – connections EN 1092-1, PN 10 and PN 16

DN	NPS	I1	d1	C	EN 1092-1 PN 10					EN 1092-1 PN 16					[kg]
					Ø M	Tie bolt ⁴²⁾		Bolt		Ø M	Tie bolt ⁴²⁾		Bolt		
	f					Qty	X	Qty ⁴³⁾	f		Qty	X	Qty ⁴³⁾		
[inch]															
650	26	165	835 ⁴⁴⁾	31	45)	45)	45)	45)	45)	45)	45)	45)	45)	45)	-
650	26	165	869 ⁴⁶⁾	31	45)	45)	45)	45)	45)	45)	45)	45)	45)	45)	-
700	28	165	895 ⁴⁴⁾	32,5	M27	32	20	27	4	-	-	-	-	-	330
700	28	165	925 ⁴⁷⁾	32,5	-	-	-	-	-	M33	38	20	25	4	350
750	30	190	965 ⁴⁴⁾	33,5	-	-	-	-	-	-	-	-	-	-	405
750	30	190	985 ⁴⁷⁾	33,5	-	-	-	-	-	-	-	-	-	-	425
800	32	190	1015 ⁴⁴⁾	35	M30	35	20	30	4	-	-	-	-	-	505
800	32	190	1075 ⁴⁷⁾	35	-	-	-	-	-	M36	42	20	36	4	525
900	36	203	1115 ⁴⁴⁾	37,5	M30	35	24	30	4	-	-	-	-	-	590
900	36	203	1160 ⁴⁷⁾	37,5	-	-	-	-	-	M36	42	24	36	4	620
1000	40	216	1230 ⁴⁴⁾	40	M33	38	24	33	4	-	-	-	-	-	740
1000	40	216	1275 ⁴⁷⁾	40	-	-	-	-	-	M39	45	24	29	4	780

Table 50: Dimensions [mm] and weights [kg] for flanged body with flat faces T5 – connections JIS B2220, B2238, B2239 10K and 16K

DN	NPS	I1	d1	C	JIS B2220, B2238, B2239 10K					JIS B2220, B2238, B2239 16K					[kg]
					Ø M	Tie bolt ⁴²⁾		Bolt		Ø M	Tie bolt ⁴²⁾		Bolt		
	f					Qty	X	Qty ⁴³⁾	f		Qty	X	Qty ⁴³⁾		
[inch]															
650	26	165	835 ⁴⁴⁾	31	M30	35	20	37	4	M30	35	20	37	4	285
650	26	165	869 ⁴⁶⁾	31	-	-	-	-	-	-	-	-	-	-	305
700	28	165	895 ⁴⁴⁾	32,5	M30	35	20	37	4	M30	35	20	37	4	330
700	28	165	925 ⁴⁷⁾	32,5	-	-	-	-	-	-	-	-	-	-	350
750	30	190	965 ⁴⁴⁾	33,5	M30	35	20	37	4	M30	35	20	37	4	405
750	30	190	985 ⁴⁷⁾	33,5	-	-	-	-	-	-	-	-	-	-	425
800	32	190	1015 ⁴⁴⁾	35	M30	35	24	37	4	M30	35	24	37	4	505
800	32	190	1075 ⁴⁷⁾	35	-	-	-	-	-	-	-	-	-	-	525
900	36	203	1115 ⁴⁴⁾	37,5	M30	35	24	37	4	M30	35	24	37	4	590
900	36	203	1160 ⁴⁷⁾	37,5	-	-	-	-	-	-	-	-	-	-	620
1000	40	216	1230 ⁴⁴⁾	40	M36	42	24	37	4	M36	42	24	37	4	740
1000	40	216	1275 ⁴⁷⁾	40	-	-	-	-	-	-	-	-	-	-	780

⁴² Quantity of nuts = quantity of tie bolts x 2

⁴³ Quantity of bolts x 2

⁴⁴ Installation between flanges EN 1092 PN 6, 10, JIS B2220, B2238 and B2239-5K and 10K

⁴⁵ Non-standardised connection

⁴⁶ Installation between flanges EN 1092 PN 16, MSS SP 44 Cl. 150, ASME B16.1 Cl. 125

⁴⁷ Installation between flanges EN 1092 PN 16, MSS SP 44 Cl. 150, ASME B16.1 Cl. 125, AS 2129 Cl. D and E and BS 10 Cl. D and E

Table 51: Dimensions [mm] and weights [kg] for flanged body with flat faces T5 – connections ASME and MSS SP 44 Cl. 150

DN	NPS	l1	d1	C	ASME B16.5 Class 150 ⁴⁸⁾ ASME B16.1 Class 125 ⁴⁸⁾ MSS SP 44 Cl.150 ⁴⁸⁾ ASME B16.47 Cl.150 Serie A ⁴⁸⁾					[kg]
					UNC	Tie bolt ⁴²⁾		Bolt		
	[inch]					f	Qty	X	Qty ⁴³⁾	
650	26	165	835 ⁴⁴⁾	31	-	-	-	-	-	285
650	26	165	869 ⁴⁶⁾	31	1"¼	38	20	25	4	305
700	28	165	895 ⁴⁴⁾	32,5	-	-	-	-	-	330
700	28	165	925 ⁴⁷⁾	32,5	1"¼	38	24	25	4	350
750	30	190	965 ⁴⁴⁾	33,5	-	-	-	-	-	405
750	30	190	985 ⁴⁷⁾	33,5	1"¼	38	24	33	4	425
800	32	190	1015 ⁴⁴⁾	35	-	-	-	-	-	505
800	32	190	1075 ⁴⁷⁾	35	1"½	45	24	29	4	525
900	36	203	1115 ⁴⁴⁾	37,5	-	-	-	-	-	590
900	36	203	1160 ⁴⁷⁾	37,5	1"½	45	28	29	4	620
1000	40	216	1230 ⁴⁴⁾	40	-	-	-	-	-	740
1000	40	216	1275 ⁴⁷⁾	40	1"½	45	32	35	4	780

⁴⁸⁾ For DN's concerned, see connection standards.



KSB S.A.S.
4, allée des Barbanniers • 92635 Gennevilliers Cedex (France)
Tél. 09 69 39 29 79
www.ksb.fr