



CDLF+CDH, HP 50Hz/60Hz High Pressure Pump



Nanfeng Pump Industry Co.,Ltd.

CNP Headquarter
Address: Renhe Town, Hangzhou China
PostCode: 311107
Tel: +86 571 86397810 , 86397838
Fax: +86 571 86397809
E-mail: info@nanfang-pump.com
<http://www.cnppump.com>

E190908
subject to amendments



Company Profile



Founded in 1991, Nanfang Pump Industry Co., Ltd. (hereinafter referred to as CNP) has been listed on the Shenzhen Stock Exchange on 9th December 2010; Stock name: CNP; Stock code: 300145.

As the first enterprise specializing in the research and large-scale production of stainless steel stamping welded centrifugal pump in China, CNP is currently the professional manufacturer with the highest volume of production and marketing in that industry. It ranks first in the country in terms of product scope, sales volume, and production quality. The company has set up a complete network of marketing services to meet the requirements of overseas markets as well as domestic needs. The products have seen a wide range of application in the area of pressurization, industry, living water, cycling of air-conditioning water, heat supply, fire extinguishing system, pumping of underground water, treatment of sewage and waste water, chemical industry and desalination of sea water etc.

CNP has now entered into the fast track of development and has taken a major step forward in forging China Strong Pump Enterprise and World's famous brand in the Pump Industry. In order to better meet the client's needs and requirements for expansion, it has set up a wide network of selling and service, as well as offices and service centers in major cities in China, which are aimed at providing timely and effective services for our clients. Meanwhile, our company has successfully penetrated into the world market by forging a good business relationship with more than 50 countries and regions in the Europe, Northern American, and Southeast Asia etc.

Content

General Data

Performance scope	3
Product range	4
Working conditions	5
Applications	5
Connection	5
Motor	5
Performance curve	5
Definition of model	5
Features	6
Pump	6
Sectional drawings	7
Max. working pressure	10
Min. inlet pressure NPSH	10

Technical Data

CDLF1+CDH1-36,50Hz	11
CDLF2+CDH2-26,50Hz	13
CDLF3+CDH3-36,50Hz	15
CDLF4+CDH4-22,50Hz	17
CDLF8+CDH8-20,50Hz	19
CDLF12+CDH12-18,50Hz	21
CDLF15+CDH15-17,50Hz	23
CDLF20+CDH20-17,50Hz	25
HP32,50Hz	27
HP42,50Hz	29
CDLF1+CDH1-25,60Hz	31
CDLF2+CDH2-18,60Hz	33
CDLF3+CDH3-25,60Hz	35
CDLF4+CDH4-16,60Hz	37
CDLF8+CDH8-14,60Hz	39
CDLF12+CDH12-14,60Hz	41
CDLF15+CDH15-12,60Hz	43
CDLF20+CDH20-10,50Hz	45
HP32,60Hz	47
HP42,60Hz	49

Performance scope

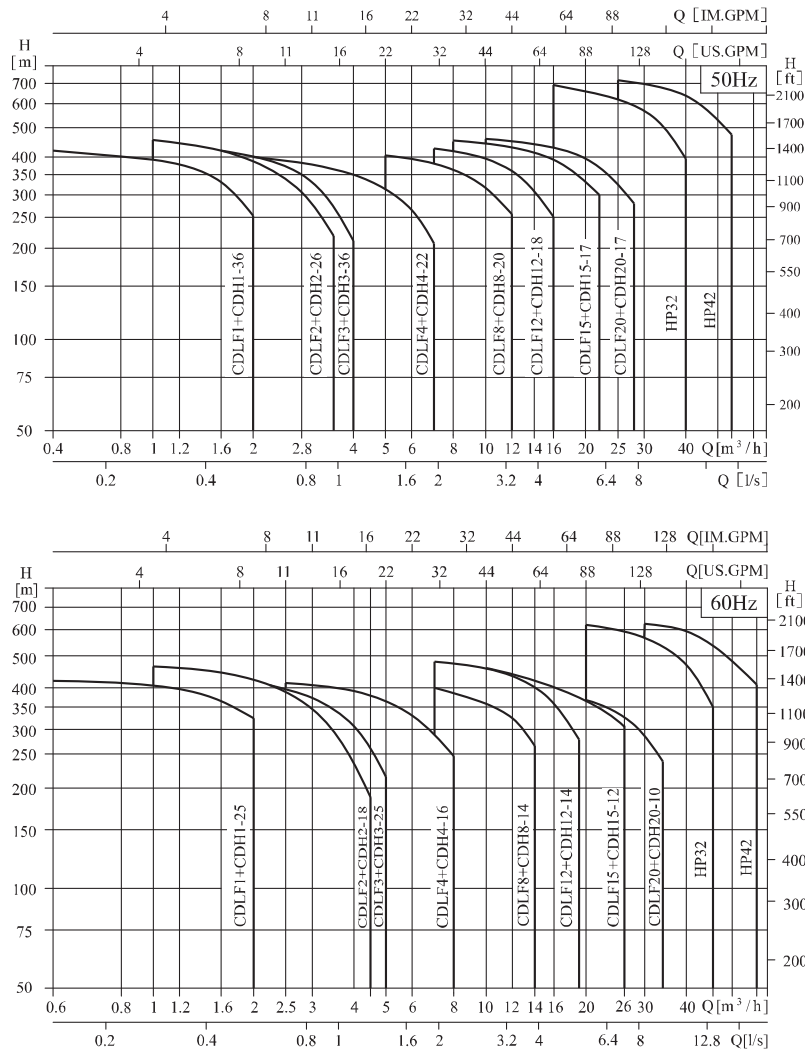

Product range

Remark	CDLF1+ CDH1-36	CDLF2+ CDH2-26	CDLF3+ CDH3-36	CDLF4+ CDH4-22	CDLF8+ CDH8-20	CDLF12+ CDH12-18	CDLF15+ CDH15-17	CDLF20+ CDH20-17	HP32	HP42
50Hz										
Nominal flow [m³/h]	1	2	3	4	8	12	15	20	32	42
Nominal flow [l/s]	0.28	0.56	0.83	1.1	2.2	3.3	4.17	5.6	8.9	11.7
Flow range [m³/h]	0.4-2	1-3.5	1.2-4	1.5-7	5-12	7-16	8-22	10-28	16-40	25-55
Flow range [l/s]	0.11-0.56	0.28-0.97	0.33-1.1	0.42-1.9	1.4-3.3	1.9-4.4	2.2-6.1	2.8-7.8	4.4-11.1	6.9-15.3
Max. pressure [bar]	42	46	44	42	42	44	44	46	70	72
Power [kW]	2.57-4.4	3.37-6	3.37-6	4.37-8	8.25-15	12.5-22	16.1-30	19.6-37	37-74	55-110
Temp. [°C]	-15 ~ +120									
Max. efficiency [%]	42	44	52	56	61	62	70	69	73	75
Type										
Vertical	●	●	●	●	●	●	●	●		
Horizontal									●	●
Pipelines										
P/E coupling	●	●	●	●	●	●	●	●	●	●
System										
Two pumps in serial	●	●	●	●	●	●	●	●		
Single pump or two pumps in serial									●	●

Remark: Motor power is the total of two pumps in serial.

Remark	CDLF1+ CDH1-25	CDLF2+ CDH2-18	CDLF3+ CDH3-25	CDLF4+ CDH4-16	CDLF8+ CDH8-12	CDLF12+ CDH12-14	CDLF15+ CDH15-12	CDLF20+ CDH20-10	HP32	HP42
60Hz										
Nominal flow [m³/h]	1	2	3	4	8	12	15	20	32	42
Nominal flow [l/s]	0.28	0.56	0.83	1.1	2.2	3.3	4.2	5.6	8.9	11.7
Flow range [m³/h]	0.6-2	1-4.5	1.5-5	2.5-8	7-14	7-19	10-26	12-34	20-48	30-65
Flow range [l/s]	0.17-0.56	0.28-1.25	0.42-1.4	0.7-2.2	1.9-3.9	1.9-5.3	2.8-7.2	3.3-9.4	5.5-13.3	8.3-18
Max. pressure [bar]	42	47	43	42	40	48	40	40	70	72
Power [kW]	3.37-6	4.55-8	4.37-8	5.75-11	11.75-22	16.1-30	20-37	20.7-37	37-74	55-110
Temp. [°C]	-15 ~ +120									
Max. efficiency [%]	42	44	52	56	61	62	70	69	73	75
Type										
Vertical	●	●	●	●	●	●	●	●		
Horizontal									●	●
Pipelines										
P/E coupling	●	●	●	●	●	●	●	●	●	●
System										
Two pumps in serial	●	●	●	●	●	●	●	●		
Single pump or two pumps in serial									●	●

Remark: Motor power is the total of two pumps in serial.

Working conditions

- Thin, clean, non-flammable and non-explosive liquid containing no solid granules and fibers.
- Liquid temperature:
Normal temperature type: -15°C~+70°C
Hot water type: -15°C~+120°C
- Ambient temperature: up to +40°C
- Altitude: up to 1000m

Applications

- Water treatment: Ultra-filter system
- R/O system
- Booster system
- High pressure flushing system
- Water supply

Connection

- Inlet & outlet: PJE connection

Motor

- TEFC motor
- Protection class: IP55
- Insulation class: F
- Voltage: 50Hz, 3 × 380-415V
3 × 220-240/380-415V
3 × 200-220/346-380V
1 × 220-230/240V
60Hz, 3 × 200-230/346-400V
3 × 220-255/380-440V
3 × 220-277/380-480V

Performance curve

Following conditions are suitable for the performance curves shown below:

1. All curves are based on the measured values of 50Hz: constant motor speed 2900rpm or 2950rpm, 60Hz: constant motor speed 3500rpm or 3540rpm.
2. Curve tolerance in conformity to ISO9906:2012 Grade 3B.
3. Measurement is done with 20°C air-free water, kinematic viscosity of 1mm²/sec.
4. The operation of pump shall refer to the performance region indicated by the thickened curve to prevent overheating due to too small flow rate or overload of motor due to too large flow rate.

Definition of model

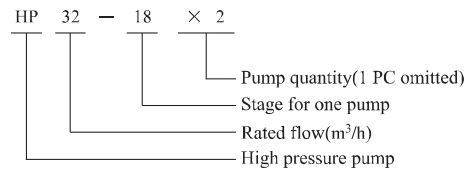
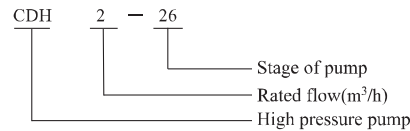

Features

- High pressure
- Standard motor
- Simple structure, reliable, high efficient, light and aesthetic
- Cartridge mechanical seal, easy for service.

Pump I. CDH

- Two pumps (CDLF & CDH) in serial produce 48 bar high pressure.
- CDLF pump supplies water, CDH is specially designed high pressure pump. The catalogue only gives technical information.
- CDH pump is non-priming vertical multistage centrifugal pump installed standard motor. Motor is coupled with pump shaft. Staybolts fix cylinder, wetting parts between pump head and inlet & outlet chamber. Inlet & outlet chamber and pump base are in the same line. Rotating direction is the reverse direction of water supply pump, chambers are reverse. The pumped liquid flowed reversely. The cylinder and mechanical seal only bear the outlet pressure of water supply pump, increased the reliability.

Pump II HP

- Two pumps assembled to pump sets in serial or only one pump, pump is coupled with standard motor by rigid coupling.
- Pump is installed horizontally.
- Impellers are installed back to back, so as to balance the big trust force of the pump.
- For the wet parts, for HP model, it is SS304 or SS316.

Sectional drawing CDH1,2,3,4

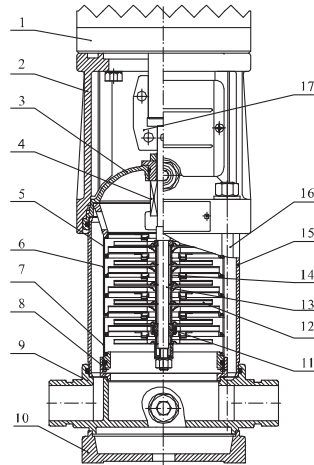

Material CDH1,2,3,4

NO.	Name	Material	AISI/ASTM	NO.	Name	Material	AISI/ASTM
1	Motor			9	Inlet and outlet chamber	Stainless steel	AISI304
2	Pump head	Cast iron	ASTM80-55-06	10	Base plate	Cast iron	
3	Lining			11	Bearing	Tungsten carbide	
4	Mechanical seal			12	Impeller	Stainless steel	AISI304
5	Top diffuser	Stainless steel	AISI304	13	Shaft	Stainless steel	AISI304 AISI316L
6	Diffuser	Stainless steel	AISI304	14	Impeller sleeve	Stainless steel	AISI304
7	Support diffuser	Stainless steel	AISI304	15	Cylinder	Stainless steel	AISI304
8	Inducer	Stainless steel	AISI304	16	Staybolt	Stainless steel	
				17	Coupling	Carbon steel	

Sectional drawing CDH8,12,15,20

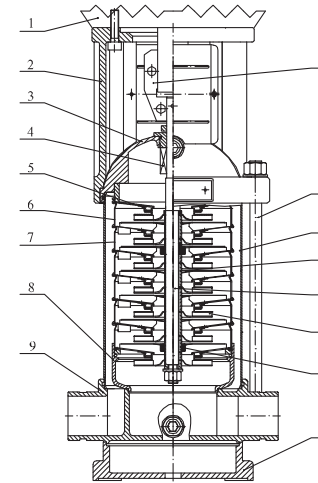

CDH8

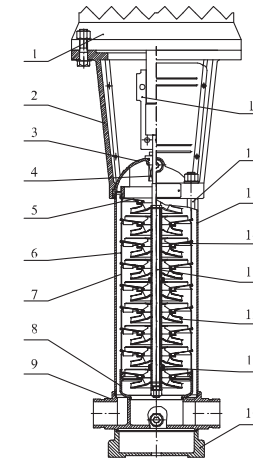

CDH12,15,20

Material CDH8,12,15,20

NO.	Name	Material	AISI/ASTM	NO.	Name	Material	AISI/ASTM
1	Motor			9	Inlet and outlet chamber	Stainless steel	AISI304
2	Pump head	Cast iron	ASTM80-55-06	10	Base plate	Cast iron	
3	Lining			11	Bearing	Tungsten carbide	
4	Mechanical seal			12	Impeller	Stainless steel	AISI304
5	Top diffuser	Stainless steel	AISI304	13	Shaft	Stainless steel	AISI304 AISI316L
6	Diffuser	Stainless steel	AISI304	14	Impeller sleeve	Stainless steel	AISI304
7	Support diffuser	Stainless steel	AISI304	15	Cylinder	Stainless steel	AISI304
8	Inducer	Stainless steel	AISI304	16	Staybolt	Stainless steel	
				17	Coupling	Carbon steel	

Sectional drawing

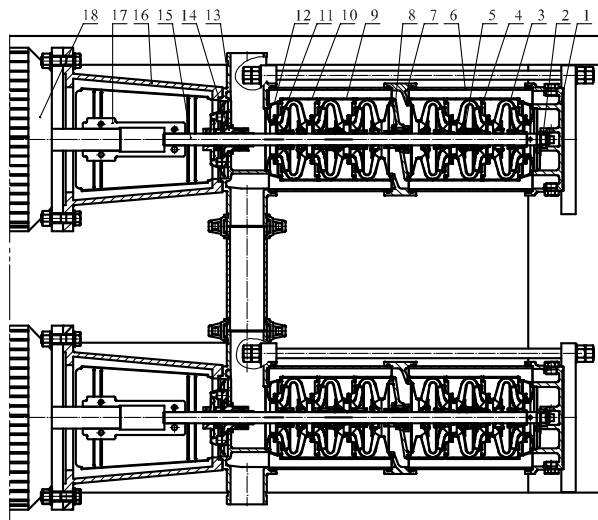
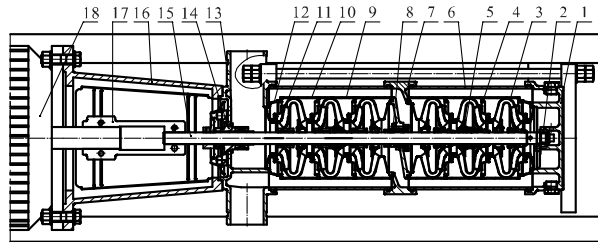

NO.	Name	Material	AISI/ASTM	NO.	Name	Material	AISI/ASTM
1	Base	Stainless steel	AISI304	10	Reverse chamber	Stainless steel	AISI304
2	Bottom bearing			11	Reverse impeller	Stainless steel	AISI304
3	Chamber	Stainless steel	AISI304	12	Inducer	Stainless steel	AISI304
4	Impeller	Stainless steel	AISI304	13	Inlet and outlet chamber	Stainless steel	AISI304
5	Intermediate bearing			14	Mechanical seal		
6	Outer sleeve	Stainless steel	AISI304	15	Pump shaft	Stainless steel	AISI304/AISI431
7	Exchange chamber	Stainless steel	AISI304	16	Bracket	Cast iron	ASTM25B
8	Exchange chamber bearing			17	Coupling	Carbon steel	
9	Support reverse chamber	Stainless steel	AISI304	18	Motor		

Max. working pressure

- CDH1,2,3,4,8,12,15,20:50bar
- HP

50Hz	60Hz
HP32-17~HP32-19, HP32-10×2: 40bar	HP32-10~HP32-12, HP32-7×2: 40bar
HP32-11×2~HP32-16×2: 63bar	HP32-8×2~HP32-11×2: 63bar
HP32-17×2~HP32-19×2: 75bar	HP32-12×2: 75bar
HP42-14, HP42-15, HP42-8×2: 40bar	HP42-8, HP42-9, HP42-5×2: 40bar
HP42-9×2~HP42-12×2: 63bar	HP42-6×2~HP42-8×2: 63bar
HP42-13×2~HP42-15×2: 75bar	HP42-9×2: 75bar

Minimum inlet pressure NPSH

- CDH:CDH1,2,3,4,8,12,15,20:0.5bar
- CDLF,HP:

In case that the pressure in pump is lower than the steam pressure used to convey liquid, the cavitations will occur. To avoid cavitations, a minimum pressure at the inlet side of the pump shall be guaranteed. The maximum suction stroke can be calculated with following formula:

$$H = P_b \times 10.2 - NPSH - H_f - H_v - H_s$$

P_b = atmosphere pressure [bar]

(can be set as 1 bar)

In a closed system, P_b means system pressure [bar]

NPSH = Net positive suction head [m]

(It can be read out from the point of possible max. Flow rate shown on NPSH curve)

H_f = Pipeline loss at the inlet [m]

H_v = Steam pressure [m]

H_s = Safety margin = Minimum 0.5m delivery head

If the calculated result H is positive, the pump may run under the max. Suction stroke H .

In case the calculated result H is negative, a delivery head of min. Inlet pressure is necessary.

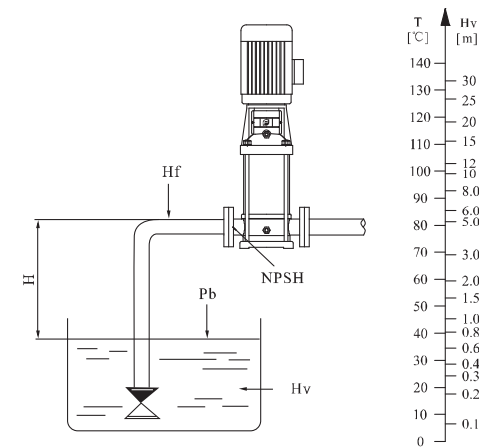

Performance curve

ISO9906 Annex A 2900rpm

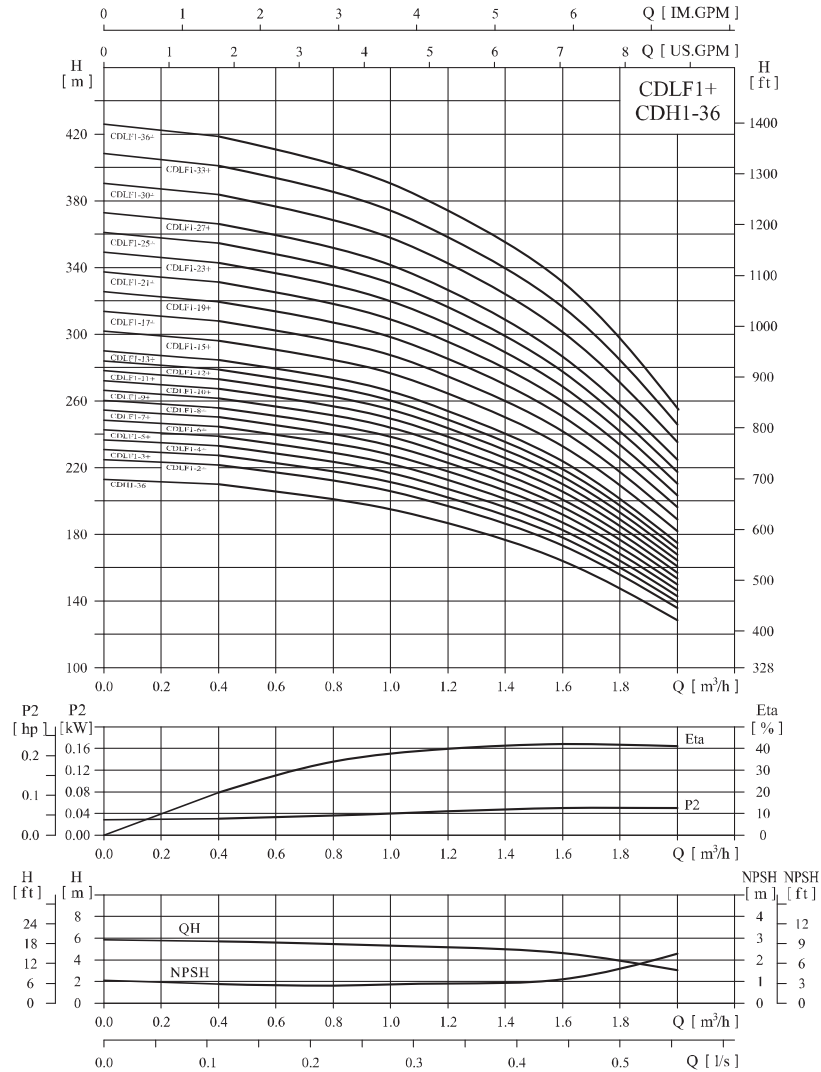

Performance table

Model	Driving motor (kw)	Q (m³/h)	0.4	0.6	0.8	1.0	1.2	1.4	1.6	1.8	2.0
CDLF1-2+CDH1-36	0.37+2.2	H (m)	221	216.5	211	205.5	197	186.5	175	157.5	136
CDLF1-3+CDH1-36	0.37+2.2		227	222	216.5	211	202.5	192	180	162	139
CDLF1-4+CDH1-36	0.37+2.2		232	227.5	222	216.5	207.5	197	184	166	143
CDLF1-5+CDH1-36	0.37+2.2		238	233.6	228	222	213	202	189	170	147
CDLF1-6+CDH1-36	0.37+2.2		244	239.5	234	227.5	219	207	193	174	150
CDLF1-7+CDH1-36	0.37+2.2		250	245	239.5	233	224	212	198	178	154
CDLF1-8+CDH1-36	0.55+2.2		256	251	245	239	229	217	203	182	157
CDLF1-9+CDH1-36	0.55+2.2		262	257	251	245	235	222	208	187	160
CDLF1-10+CDH1-36	0.55+2.2		268	263	257	251	240	227	213	191	163
CDLF1-11+CDH1-36	0.55+2.2		274	269	262	255	245	232	217	195	167
CDLF1-12+CDH1-36	0.75+2.2		280	275	268	261	250	237	222	199	171
CDLF1-13+CDH1-36	0.75+2.2		286	281	274	267	255	242	227	203	174
CDLF1-15+CDH1-36	0.75+2.2		297	292	285	278	265	252	236	211	182
CDLF1-17+CDH1-36	1.1+2.2		309	303	296	289	275	262	245	219	189
CDLF1-19+CDH1-36	1.1+2.2		321	314	307	300	285	272	254	227	196
CDLF1-21+CDH1-36	1.1+2.2		332	326	319	311	296	282	263	235	202
CDLF1-23+CDH1-36	1.1+2.2		345	337	330	322	307	292	272	244	209
CDLF1-25+CDH1-36	1.5+2.2		357	349	342	333	317	302	281	252	216
CDLF1-27+CDH1-36	1.5+2.2		369	361	354	344	327	312	290	260	222
CDLF1-30+CDH1-36	1.5+2.2		386	379	370	360	343	326	304	272	233
CDLF1-33+CDH1-36	2.2+2.2	404	396	387	377	359	341	319	285	245	
CDLF1-36+CDH1-36	2.2+2.2	422	414	404	394	376	357	334	299	257	

Installation sketch

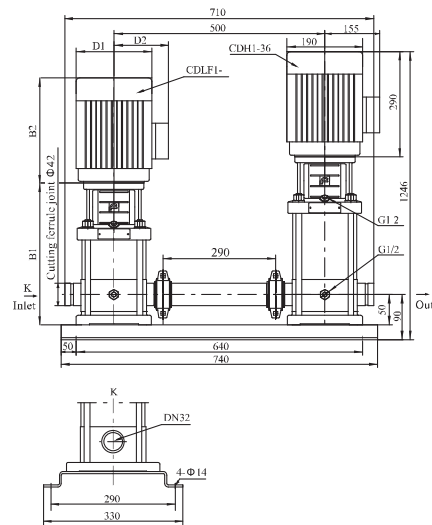

Size and weight

Model	Size (mm)					Weight (kg)
	B1	B2	B1+B2	D1	D2	
CDLF1-2+CDH1-36	233	225	458	148	117	81
CDLF1-3+CDH1-36	251	225	476	148	117	81
CDLF1-4+CDH1-36	269	225	494	148	117	81
CDLF1-5+CDH1-36	287	225	512	148	117	81
CDLF1-6+CDH1-36	305	225	530	148	117	81
CDLF1-7+CDH1-36	323	225	548	148	117	81
CDLF1-8+CDH1-36	341	225	566	148	117	83
CDLF1-9+CDH1-36	359	225	584	148	117	83
CDLF1-10+CDH1-36	377	225	602	148	117	83
CDLF1-11+CDH1-36	395	225	620	148	117	83
CDLF1-12+CDH1-36	423	245	668	170	142	86
CDLF1-13+CDH1-36	441	245	686	170	142	86
CDLF1-15+CDH1-36	477	245	722	170	142	86
CDLF1-17+CDH1-36	513	245	758	170	142	89
CDLF1-19+CDH1-36	549	245	794	170	142	89
CDLF1-21+CDH1-36	585	245	830	170	142	91
CDLF1-23+CDH1-36	621	245	866	170	142	94
CDLF1-25+CDH1-36	667	290	957	190	155	101
CDLF1-27+CDH1-36	703	290	993	190	155	101
CDLF1-30+CDH1-36	757	290	1047	190	155	101
CDLF1-33+CDH1-36	811	290	1101	190	155	106
CDLF1-36+CDH1-36	865	290	1155	190	155	106

● Performance curve

ISO9906 Annex A 2900rpm

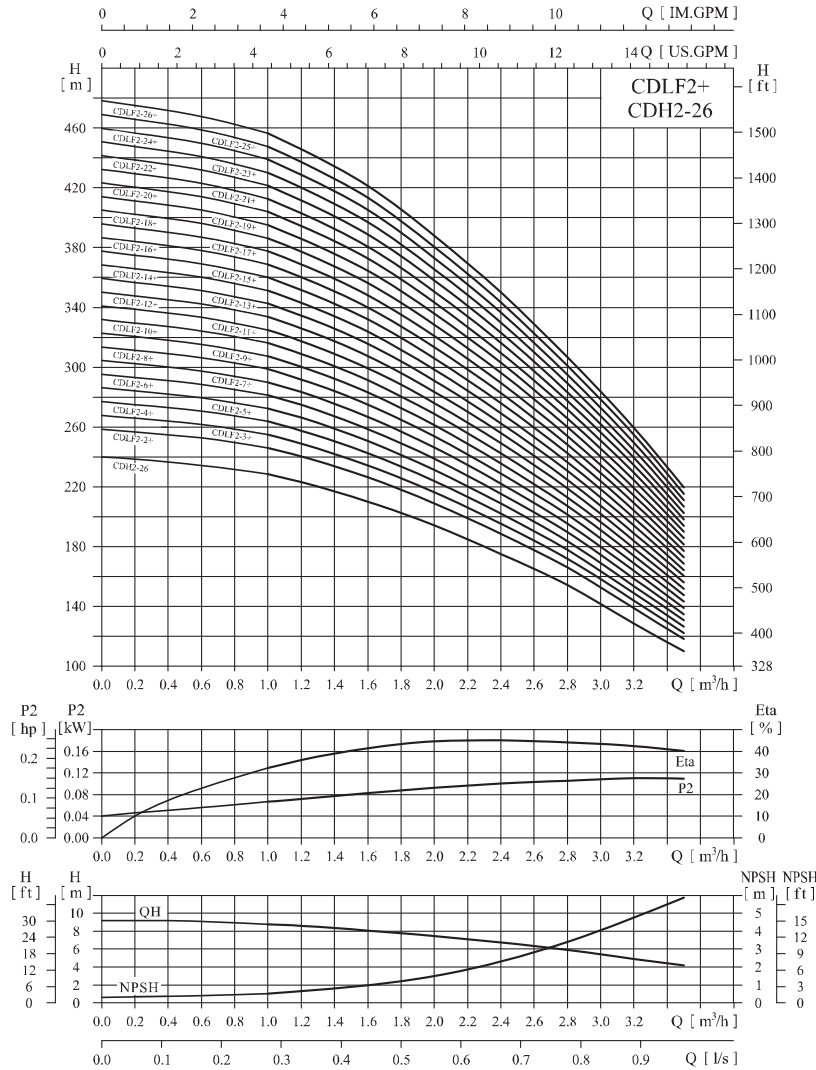

● Performance table

Model	Driving motor (kW)	Q (m³/h)	1.0	1.2	1.6	2.0	2.4	2.8	3.2	3.5
CDLF2-2+CDH2-26	0.37+3.0	H (m)	245	238	224	207	186	163	136	116
CDLF2-3+CDH2-26	0.37+3.0		254	247	232	214	193	169	141	120
CDLF2-4+CDH2-26	0.55+3.0		263	256	241	222	199	175	146	124
CDLF2-5+CDH2-26	0.55+3.0		272	264	248	229	206	181	150	128
CDLF2-6+CDH2-26	0.75+3.0		280	273	258	237	213	187	156	132
CDLF2-7+CDH2-26	0.75+3.0		290	282	265	244	220	192	161	136
CDLF2-9+CDH2-26	1.1+3.0		307	299	281	259	234	205	171	145
CDLF2-11+CDH2-26	1.1+3.0		325	316	297	274	246	215	180	152
CDLF2-13+CDH2-26	1.5+3.0		343	335	314	290	262	229	191	160
CDLF2-15+CDH2-26	1.5+3.0		361	351	331	304	273	241	199	168
CDLF2-18+CDH2-26	2.2+3.0		388	378	356	328	294	259	217	184
CDLF2-22+CDH2-26	2.2+3.0		424	413	388	357	321	281	236	198
CDLF2-26+CDH2-26	3.0+3.0		459	449	422	390	352	309	256	218

● Installation sketch

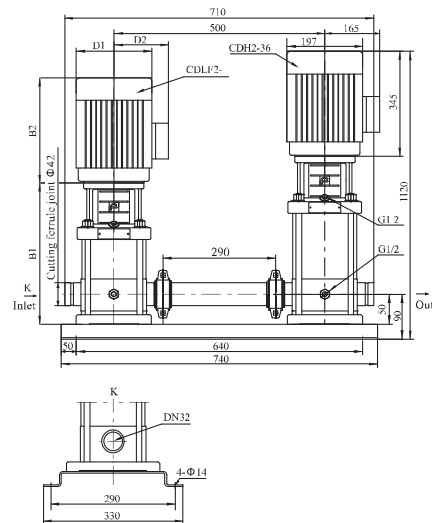

● Size and weight

Model	Size (mm)					Weight (kg)
	B1	B2	B1+B2	D1	D2	
CDLF2-2+CDH2-26	233	225	458	148	117	86
CDLF2-3+CDH2-26	251	225	476	148	117	86
CDLF2-4+CDH2-26	269	225	494	148	117	86
CDLF2-5+CDH2-26	287	225	512	148	117	86
CDLF2-6+CDH2-26	315	245	560	170	142	91
CDLF2-7+CDH2-26	333	245	578	170	142	91
CDLF2-9+CDH2-26	369	245	614	170	142	96
CDLF2-11+CDH2-26	405	245	650	170	142	96
CDLF2-13+CDH2-26	451	290	741	190	155	101
CDLF2-15+CDH2-26	487	290	777	190	155	101
CDLF2-18+CDH2-26	541	290	831	190	155	106
CDLF2-22+CDH2-26	613	290	903	190	155	111
CDLF2-26+CDH2-26	695	345	1040	197	165	116

Performance curve

ISO9906 Annex A 2900rpm

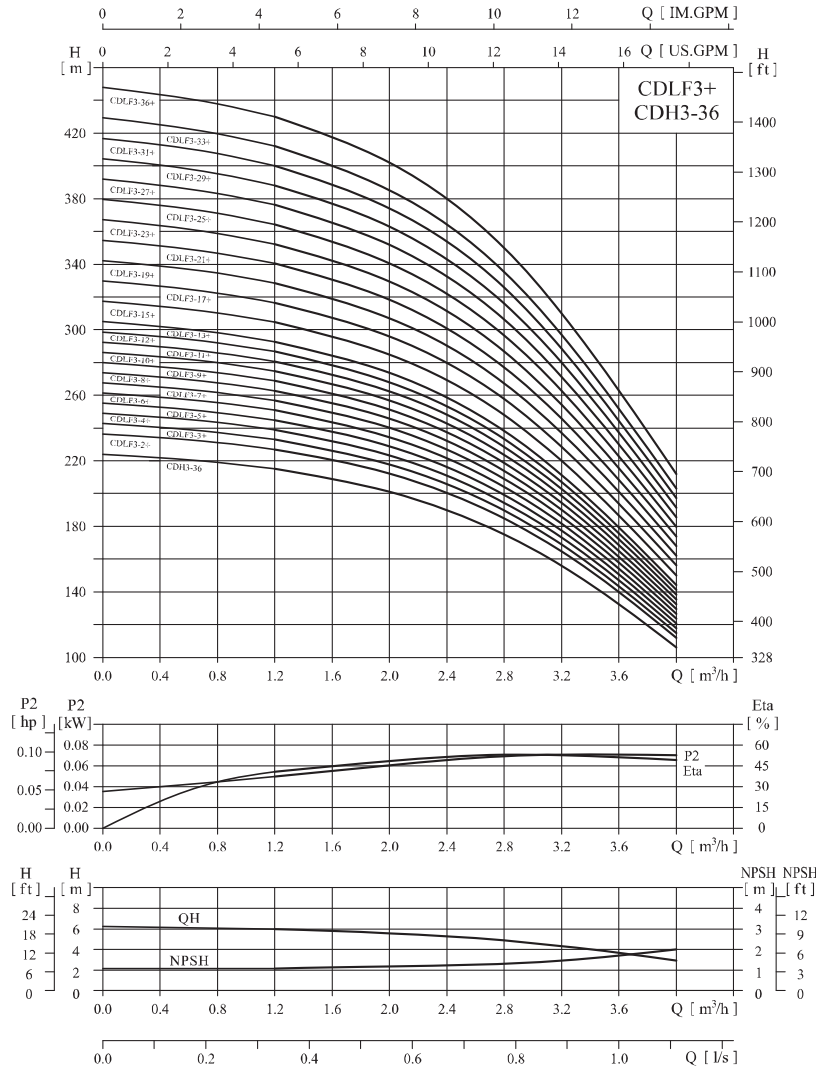

Performance table

Model	Driving motor (kw)	Q (m³/h)	1.2	1.6	2.0	2.4	2.8	3.0	3.2	3.6	4.0
CDLF3-2+CDH3-36	0.37+3.0		226.5	219.5	211	198.5	184	173	162	138	111
CDLF3-3+CDH3-36	0.37+3.0		233	226.5	217.5	204.5	189	178	167	142	114
CDLF3-4+CDH3-36	0.37+3.0		239	232	223	209.5	194	183	172	146	117
CDLF3-5+CDH3-36	0.37+3.0		245	238	229	215	199	187	176	150	121
CDLF3-6+CDH3-36	0.55+3.0		250	243	234	220	204	192	181	154	124
CDLF3-7+CDH3-36	0.55+3.0		257	249	239	225	208	196	185	158	127
CDLF3-8+CDH3-36	0.75+3.0		263	255	245	231	213	201	189	162	130
CDLF3-9+CDH3-36	0.75+3.0		269	261	251	236	219	206	194	166	133
CDLF3-10+CDH3-36	0.75+3.0		275	267	257	242	224	211	199	170	136
CDLF3-11+CDH3-36	1.1+3.0		281	272	261	246	228	215	203	173	139
CDLF3-12+CDH3-36	1.1+3.0		287	278	267	251	232	219	206	176	142
CDLF3-13+CDH3-36	1.1+3.0		292	284	273	257	238	224	211	180	145
CDLF3-15+CDH3-36	1.1+3.0		304	296	284	267	247	233	220	188	151
CDLF3-17+CDH3-36	1.5+3.0		317	308	296	278	257	243	229	195	157
CDLF3-19+CDH3-36	1.5+3.0		329	320	307	288	266	252	237	203	163
CDLF3-21+CDH3-36	2.2+3.0		342	332	319	300	276	262	245	210	169
CDLF3-23+CDH3-36	2.2+3.0		354	343	330	310	286	271	254	217	175
CDLF3-25+CDH3-36	2.2+3.0		365	355	341	319	296	280	263	225	181
CDLF3-27+CDH3-36	2.2+3.0		378	367	352	331	306	288	271	232	187
CDLF3-29+CDH3-36	2.2+3.0		389	378	363	341	316	297	280	240	193
CDLF3-31+CDH3-36	3.0+3.0		401	390	375	353	327	306	289	247	199
CDLF3-33+CDH3-36	3.0+3.0		413	402	387	364	337	315	299	256	205
CDLF3-36+CDH3-36	3.0+3.0		432	420	404	380	352	332	313	268	214

Installation sketch

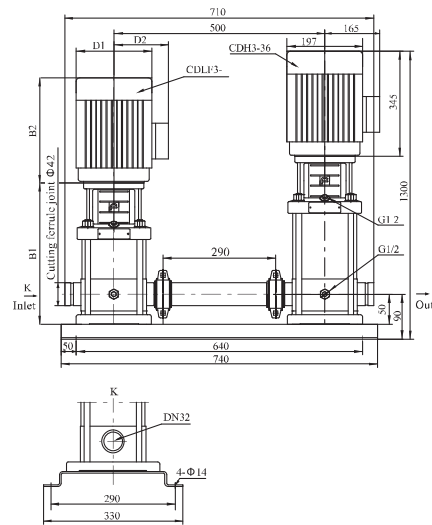

Size and weight

Model	Size (mm)					Weight (kg)
	B1	B2	B1+B2	D1	D2	
CDLF3-2+CDH3-36	233	225	458	148	117	86
CDLF3-3+CDH3-36	251	225	476	148	117	86
CDLF3-4+CDH3-36	269	225	494	148	117	86
CDLF3-5+CDH3-36	287	225	512	148	117	86
CDLF3-6+CDH3-36	305	225	530	148	117	88
CDLF3-7+CDH3-36	323	225	548	148	117	88
CDLF3-8+CDH3-36	351	245	596	170	142	88
CDLF3-9+CDH3-36	369	245	614	170	142	88
CDLF3-10+CDH3-36	387	245	632	170	142	88
CDLF3-11+CDH3-36	405	245	650	170	142	91
CDLF3-12+CDH3-36	423	245	668	170	142	91
CDLF3-13+CDH3-36	441	245	686	170	142	91
CDLF3-15+CDH3-36	477	245	722	170	142	91
CDLF3-17+CDH3-36	523	290	813	190	155	96
CDLF3-19+CDH3-36	559	290	849	190	155	101
CDLF3-21+CDH3-36	595	290	885	190	155	101
CDLF3-23+CDH3-36	631	290	921	190	155	106
CDLF3-25+CDH3-36	667	290	957	190	155	106
CDLF3-27+CDH3-36	703	290	993	190	155	106
CDLF3-29+CDH3-36	739	290	1029	190	155	106
CDLF3-31+CDH3-36	785	345	1130	197	165	111
CDLF3-33+CDH3-36	821	345	1166	197	165	116
CDLF3-36+CDH3-36	875	345	1229	197	165	116

Performance curve

ISO9906 Annex A 2900rpm

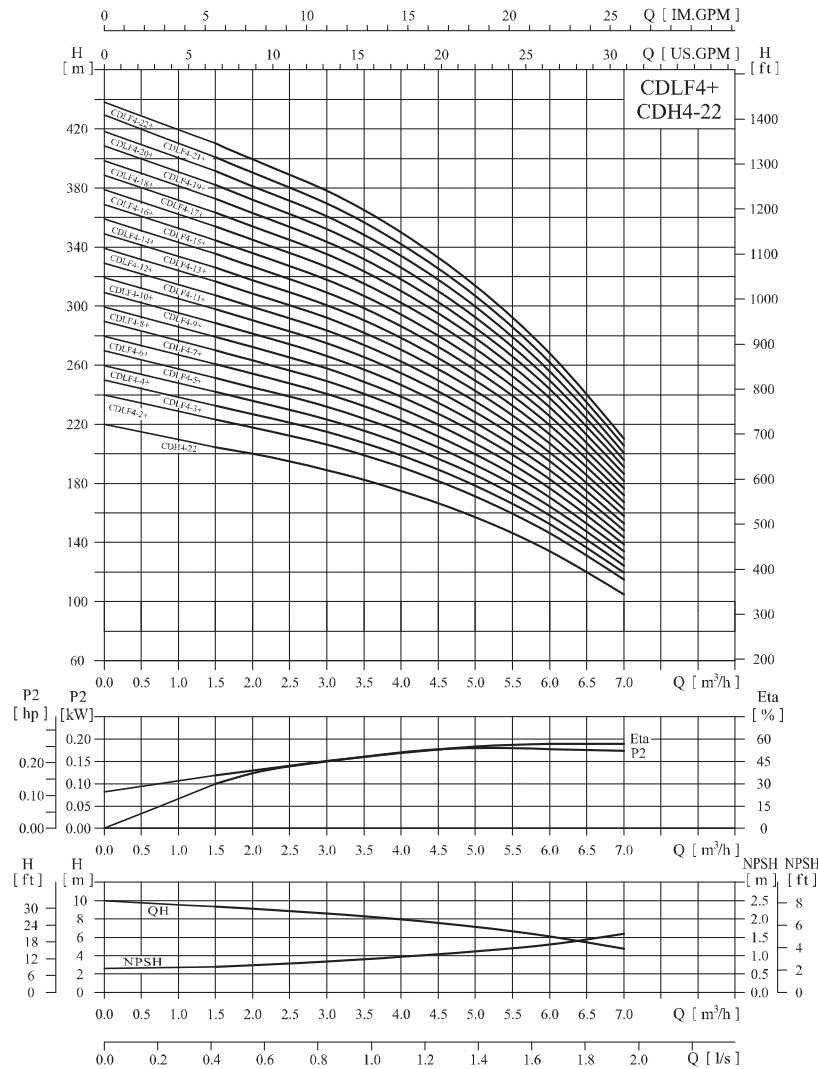

Performance table

Model	Driving motor (kW)	Q (m³/h)	1.5	2.0	3.0	4.0	5.0	6.0	7.0
CDLF4-2+CDH4-22	0.37+4.0	H (m)	221	215	205	190	170	144	111
CDLF4-3+CDH4-22	0.55+4.0		230	224	214	199	177	152	116
CDLF4-4+CDH4-22	0.75+4.0		240	233	222	207	184	158	122
CDLF4-5+CDH4-22	1.1+4.0		249	242	231	215	191	165	126
CDLF4-6+CDH4-22	1.1+4.0		258	251	240	223	198	171	131
CDLF4-7+CDH4-22	1.5+4.0		268	260	249	231	205	177	136
CDLF4-8+CDH4-22	1.5+4.0		276	269	258	239	212	184	141
CDLF4-10+CDH4-22	2.2+4.0		298	287	275	256	228	196	151
CDLF4-12+CDH4-22	2.2+4.0		316	305	292	270	242	209	161
CDLF4-14+CDH4-22	3.0+4.0		338	323	310	287	258	223	171
CDLF4-16+CDH4-22	3.0+4.0		354	341	328	304	272	235	181
CDLF4-19+CDH4-22	4.0+4.0		385	368	356	328	294	256	196
CDLF4-22+CDH4-22	4.0+4.0		413	397	380	353	317	272	211

Installation sketch

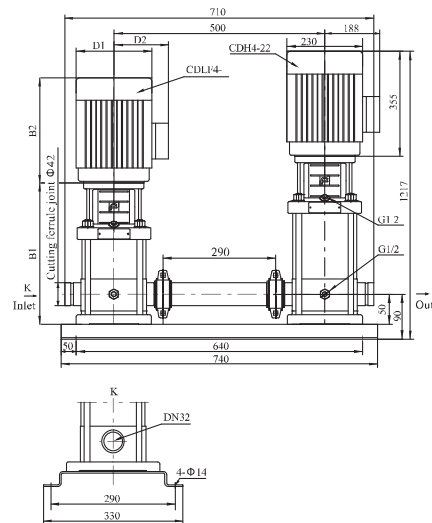

Size and weight

Model	Size (mm)					Weight (kg)
	B1	B2	B1+B2	D1	D2	
CDLF4-2+CDH4-22	251	225	476	148	117	86
CDLF4-3+CDH4-22	278	225	503	148	117	86
CDLF4-4+CDH4-22	315	245	560	170	142	86
CDLF4-5+CDH4-22	342	245	587	170	142	91
CDLF4-6+CDH4-22	369	245	614	170	142	91
CDLF4-7+CDH4-22	406	290	696	190	155	96
CDLF4-8+CDH4-22	433	290	723	190	155	96
CDLF4-10+CDH4-22	487	290	777	190	155	96
CDLF4-12+CDH4-22	541	290	831	190	155	101
CDLF4-14+CDH4-22	605	345	950	197	165	101
CDLF4-16+CDH4-22	659	345	1004	197	165	106
CDLF4-19+CDH4-22	740	345	1085	230	188	111
CDLF4-22+CDH4-22	821	355	1176	230	188	116

Performance curve

ISO9906 Annex A 2900rpm

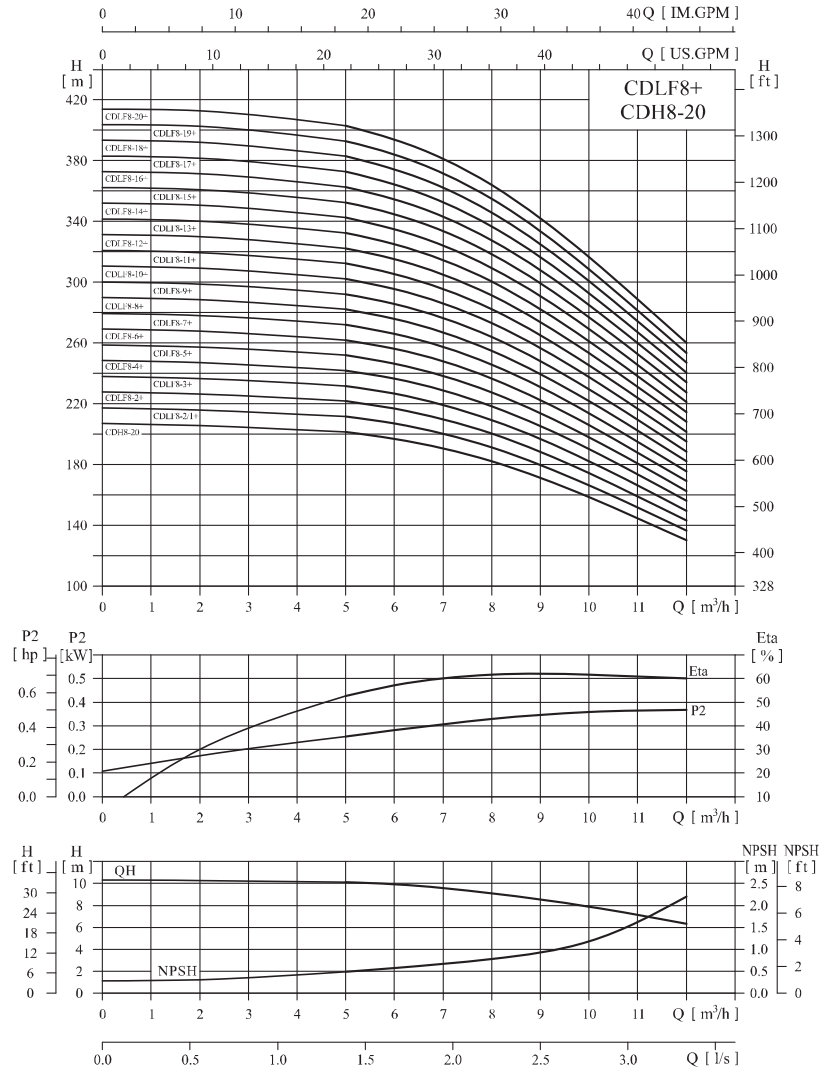

Performance table

Model	Driving motor (kW)	Q (m³/h)	5	6	7	8	9	10	11	12
CDLF8-2/1+CDH8-20	0.75+7.5	H (m)	211	204.5	197.3	189	177.5	164	149	134
CDLF8-2+CDH8-20	0.75+7.5		221	214.5	207	198	186	172	156	141
CDLF8-3+CDH8-20	1.1+7.5		231	224.5	216.5	207	194	180	163	147
CDLF8-4+CDH8-20	1.5+7.5		242	234.5	226	216	203	188	170	154
CDLF8-5+CDH8-20	2.2+7.5		253	245	236	225	211	196	178	160
CDLF8-6+CDH8-20	2.2+7.5		263	255	245	234	220	204	185	167
CDLF8-8+CDH8-20	3.0+7.5		284	275	265	253	238	221	200	180
CDLF8-10+CDH8-20	4.0+7.5		305	295	285	272	256	237	215	193
CDLF8-12+CDH8-20	4.0+7.5		325	315	304	291	273	248	229	206
CDLF8-14+CDH8-20	5.5+7.5		346	336	324	310	291	269	244	220
CDLF8-16+CDH8-20	5.5+7.5		367	356	344	328	308	286	260	234
CDLF8-18+CDH8-20	7.5+7.5		388	377	363	347	326	302	276	248
CDLF8-20+CDH8-20	7.5+7.5	409	397	383	366	344	319	292	263	

Installation sketch

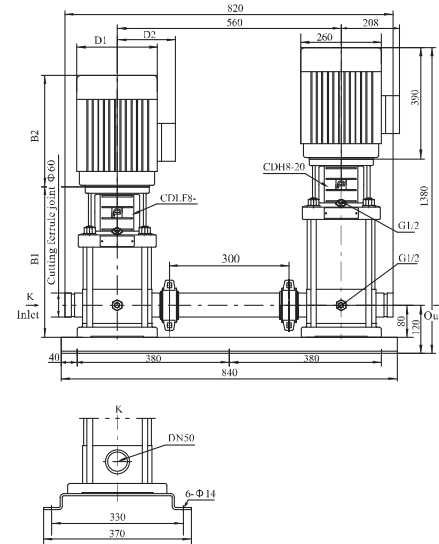

Size and weight

Model	Size (mm)					Weight (kg)
	B1	B2	B1+B2	D1	D2	
CDLF8-2/1+CDH8-20	347	245	592	170	142	136
CDLF8-2+CDH8-20	347	245	592	170	142	136
CDLF8-3+CDH8-20	377	245	622	170	142	146
CDLF8-4+CDH8-20	417	290	707	190	155	146
CDLF8-5+CDH8-20	447	290	737	190	155	156
CDLF8-6+CDH8-20	477	290	767	190	155	156
CDLF8-8+CDH8-20	547	345	892	197	165	161
CDLF8-10+CDH8-20	607	355	962	230	188	171
CDLF8-12+CDH8-20	667	355	1022	230	188	171
CDLF8-14+CDH8-20	747	390	1137	260	208	196
CDLF8-16+CDH8-20	807	390	1197	260	208	196
CDLF8-18+CDH8-20	867	390	1257	260	208	206
CDLF8-20+CDH8-20	927	390	1317	260	208	206

Performance curve

ISO9906 Annex A 2900rpm

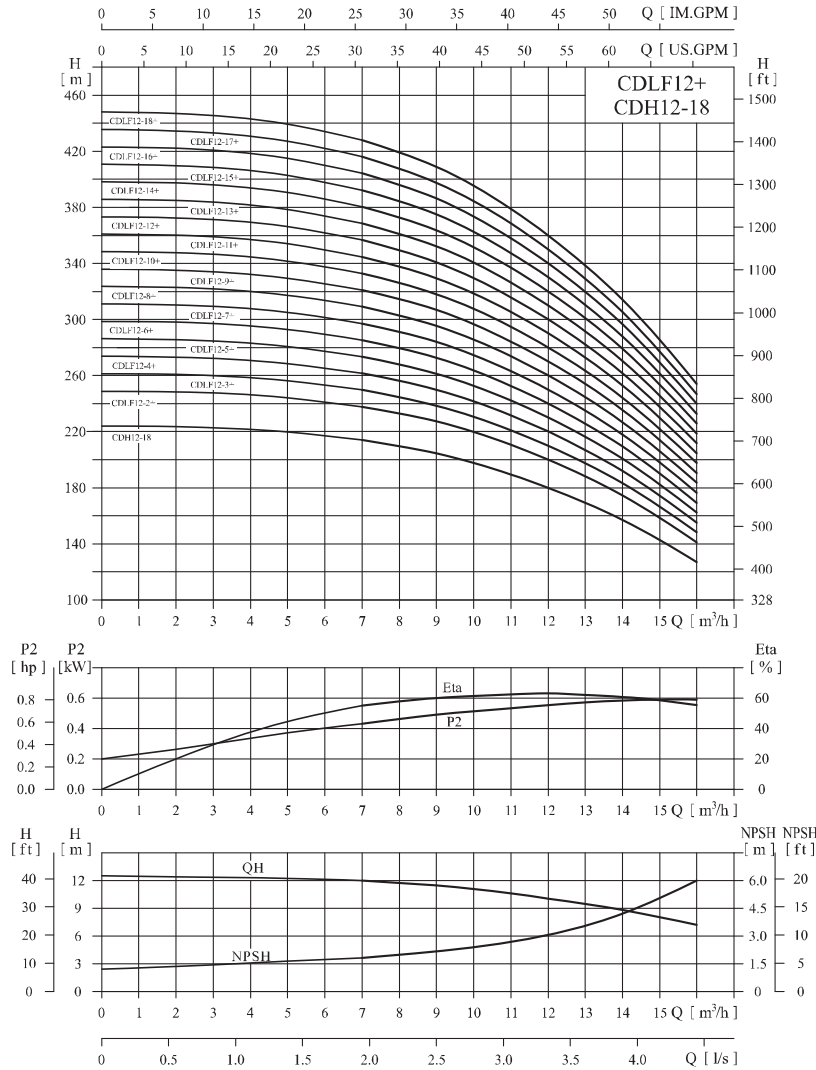

Performance table

Model	Driving motor (kW)	Q (m³/h)	7	8	9	10	11	12	13	14	15	16
CDLF12-2+CDH12-18	1.5+11	H (m)	237.5	232	225.5	218	210	200	187.5	174	157.5	141
CDLF12-3+CDH12-18	2.2+11		249.5	244	237	229	220.5	210	197	183	165.5	148
CDLF12-4+CDH12-18	3+11		261	255	248	240	231	220	206	191	173	155
CDLF12-5+CDH12-18	3+11		273.5	267	259.5	251	241.5	230	215.5	200	181	162
CDLF12-6+CDH12-18	4+11		285.5	279	271	262	252	240	225	209	189	169
CDLF12-7+CDH12-18	5.5+11		297.5	291	282.5	273	262.5	250	234.5	218	197	176
CDLF12-8+CDH12-18	5.5+11		309.5	303	294	284	273	260	244	227	205	183
CDLF12-9+CDH12-18	5.5+11		322	315	306	296	284.5	271	254	236	213.5	191
CDLF12-10+CDH12-18	7.5+11		334	327	317.5	307	295	281	263.5	245	222	199
CDLF12-12+CDH12-18	7.5+11		357.5	350	340	329	316	301	282.5	263	238	213
CDLF12-14+CDH12-18	11+11		382	374	363	351	337	321	301.5	281	254	227
CDLF12-16+CDH12-18	11+11		406.5	398	386.5	374	359	342	321	299	270.5	242
CDLF12-18+CDH12-18	11+11		431	422	410.5	398	381.5	363	340.5	317	287	257

Installation sketch

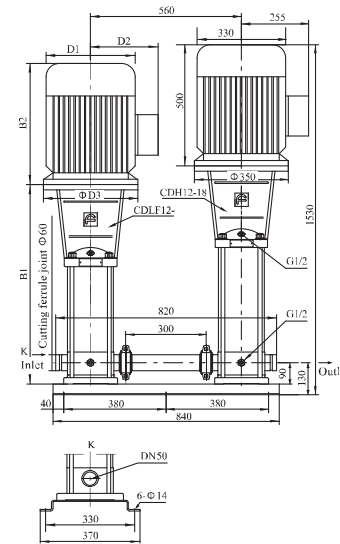

Size and weight

Model	Size (mm)						Weight (kg)
	B1	B2	B1+B2	D1	D2	D3	
CDLF12-2+CDH12-18	367	290	657	190	155	145	210
CDLF12-3+CDH12-18	397	290	687	190	155	145	213
CDLF12-4+CDH12-18	437	345	782	197	165	160	220
CDLF12-5+CDH12-18	467	345	812	197	165	160	221
CDLF12-6+CDH12-18	497	355	852	230	188	160	231
CDLF12-7+CDH12-18	547	390	937	260	208	200	249
CDLF12-8+CDH12-18	577	390	967	260	208	200	249
CDLF12-9+CDH12-18	607	390	997	260	208	200	251
CDLF12-10+CDH12-18	637	390	1027	260	208	200	251
CDLF12-12+CDH12-18	697	390	1087	260	208	200	253
CDLF12-14+CDH12-18	845	500	1345	330	255	350	324
CDLF12-16+CDH12-18	905	500	1405	330	255	350	324
CDLF12-18+CDH12-18	965	500	1465	330	255	350	326

Performance curve

ISO9906 Annex A 2900rpm

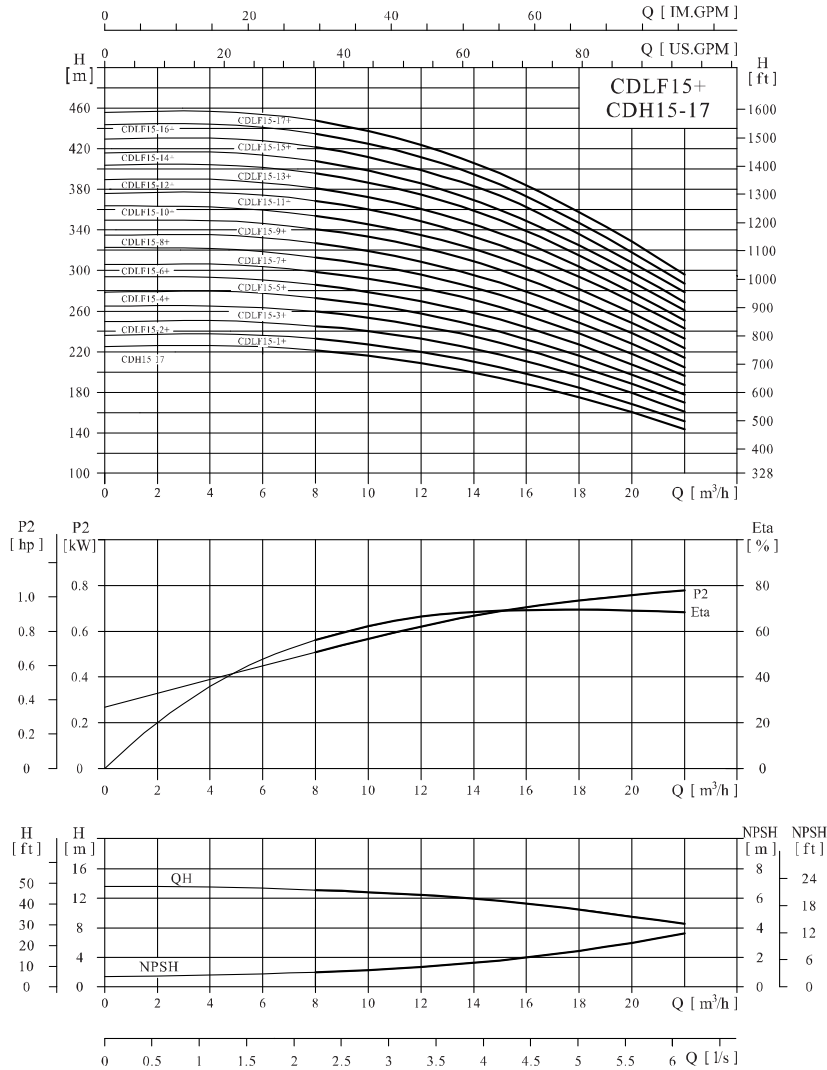

Performance table

Model	Driving motor (kW)	Q (m³/h)	8	10	12	14	15	16	18	20	22
CDLF15-1+CDH15-17	1.1+15	H (m)	233	227.5	221	211.5	206	199.5	185.5	169.5	152.5
CDLF15-2+CDH15-17	2.2+15		246	240.5	234	224	218.5	211.5	197	180	162
CDLF15-3+CDH15-17	3+15		260	254	247	236	230	223	207	190	171
CDLF15-4+CDH15-17	4+15		273	267	259	247	241	234	217	199	179
CDLF15-5+CDH15-17	4+15		286	279	271	260	253	245	228	209	188
CDLF15-6+CDH15-17	5.5+15		299	292	284	272	265	257	239	219	197
CDLF15-7+CDH15-17	5.5+15		313	306	297	284	277	269	250	229	206
CDLF15-8+CDH15-17	7.5+15		327	319	310	297	289	280	261	239	215
CDLF15-9+CDH15-17	7.5+15		341	333	324	310	302	293	272	249	225
CDLF15-10+CDH15-17	11+15		354	346	336	322	314	304	283	259	234
CDLF15-12+CDH15-17	11+15		381	373	362	347	338	328	305	279	252
CDLF15-14+CDH15-17	11+15		408	398	387	370	361	350	326	299	270
CDLF15-17+CDH15-17	15+15		448	438	425	407	397	385	359	329	297

Installation sketch

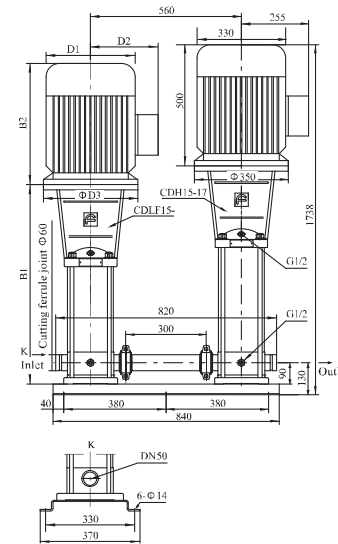

Size and weight

Model	Size (mm)						Weight (kg)
	B1	B2	B1+B2	D1	D2	D3	
CDLF15-1+CDH15-17	387	245	632	170	142	145	229
CDLF15-2+CDH15-17	397	290	687	190	155	145	238
CDLF15-3+CDH15-17	452	345	797	197	165	160	247
CDLF15-4+CDH15-17	497	355	852	230	188	160	256
CDLF15-5+CDH15-17	542	355	897	230	188	160	258
CDLF15-6+CDH15-17	607	390	997	260	208	200	274
CDLF15-7+CDH15-17	652	390	1042	260	208	200	276
CDLF15-8+CDH15-17	697	390	1087	260	208	200	282
CDLF15-9+CDH15-17	742	390	1132	260	208	200	284
CDLF15-10+CDH15-17	875	500	1375	330	255	350	353
CDLF15-12+CDH15-17	965	500	1465	330	255	350	357
CDLF15-14+CDH15-17	1055	500	1555	330	255	350	361
CDLF15-17+CDH15-17	1190	500	1690	330	255	350	374

Performance curve

ISO9906 Annex A 2900rpm

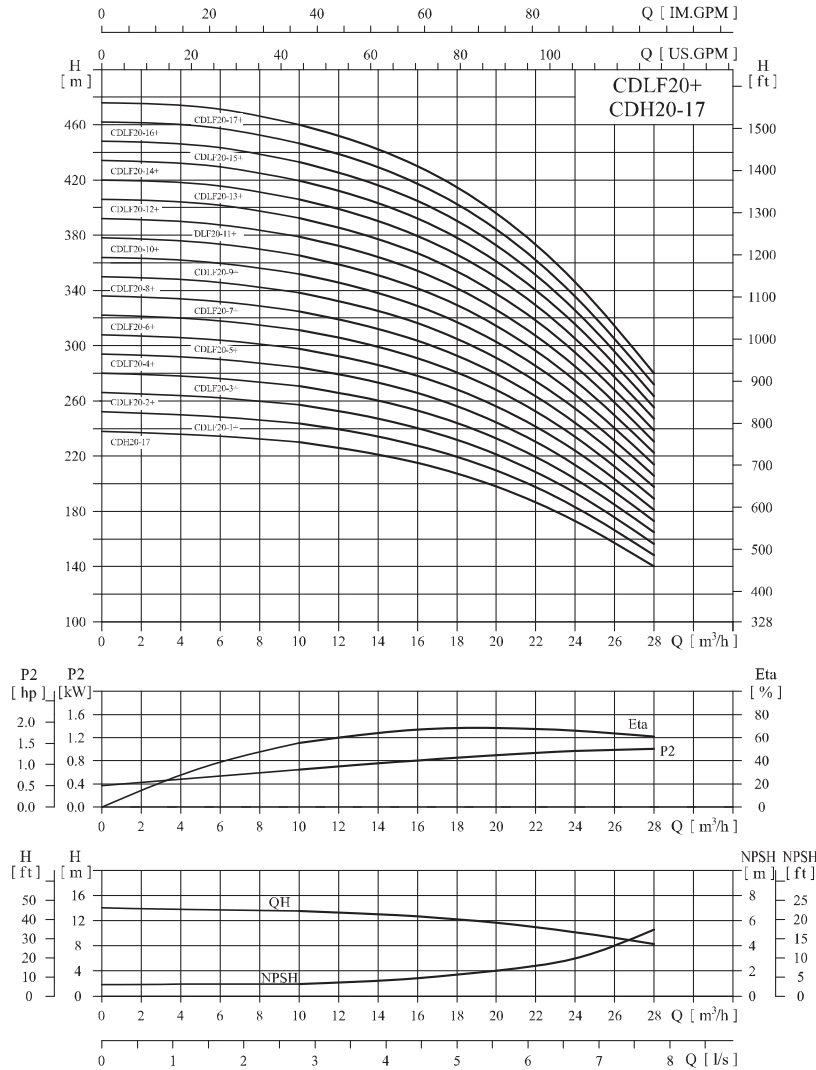

Performance table

Model	Driving motor (kW)	Q (m³/h)	10	12	14	16	18	20	22	24	26	28
CDLF20-1+CDH20-17	1.1+18.5	H (m)	241.5	237	232.5	226	217	207	194	180	164	146
CDLF20-2+CDH20-17	2.2+18.5		255	250.5	246	239	230	220	207	192	175	155
CDLF20-3+CDH20-17	4+18.5		268	263.5	259	252	243	232	218	202	184	164
CDLF20-4+CDH20-17	5.5+18.5		282	277	272	265	255	244	229	213	194	173
CDLF20-5+CDH20-17	5.5+18.5		295	290	284	276	266	255	240	222	202	180
CDLF20-6+CDH20-17	7.5+18.5		309	303	297	289	279	267	251	233	212	189
CDLF20-7+CDH20-17	7.5+18.5		323	317	311	303	292	279	262	243	222	198
CDLF20-8+CDH20-17	11+18.5		337	331	325	316	305	291	274	254	232	207
CDLF20-10+CDH20-17	11+18.5		364	358	351	342	330	315	296	275	252	225
CDLF20-12+CDH20-17	15+18.5		392	386	378	368	355	339	318	296	271	242
CDLF20-14+CDH20-17	15+18.5		420	413	405	394	380	363	341	317	290	259
CDLF20-17+CDH20-17	18.5+18.5		462	454	445	433	418	399	375	349	319	285

Installation sketch

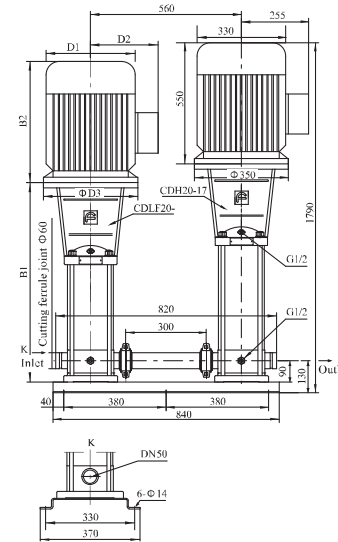

Size and weight

Model	Size (mm)						Weight (kg)
	B1	B2	B1+B2	D1	D2	D3	
CDLF20-1+CDH20-17	387	245	632	170	142	145	244
CDLF20-2+CDH20-17	397	290	687	190	155	145	255
CDLF20-3+CDH20-17	452	355	807	230	188	160	269
CDLF20-4+CDH20-17	517	390	907	260	208	200	284
CDLF20-5+CDH20-17	562	390	952	260	208	200	286
CDLF20-6+CDH20-17	607	390	997	260	208	200	294
CDLF20-7+CDH20-17	652	390	1042	260	208	200	296
CDLF20-8+CDH20-17	785	500	1285	330	255	350	352
CDLF20-10+CDH20-17	875	500	1375	330	255	350	357
CDLF20-12+CDH20-17	965	500	1465	330	255	350	372
CDLF20-14+CDH20-17	1055	500	1555	330	255	350	377
CDLF20-17+CDH20-17	1190	550	1740	330	255	350	402

Performance curve

ISO9906 Annex A 2950rpm

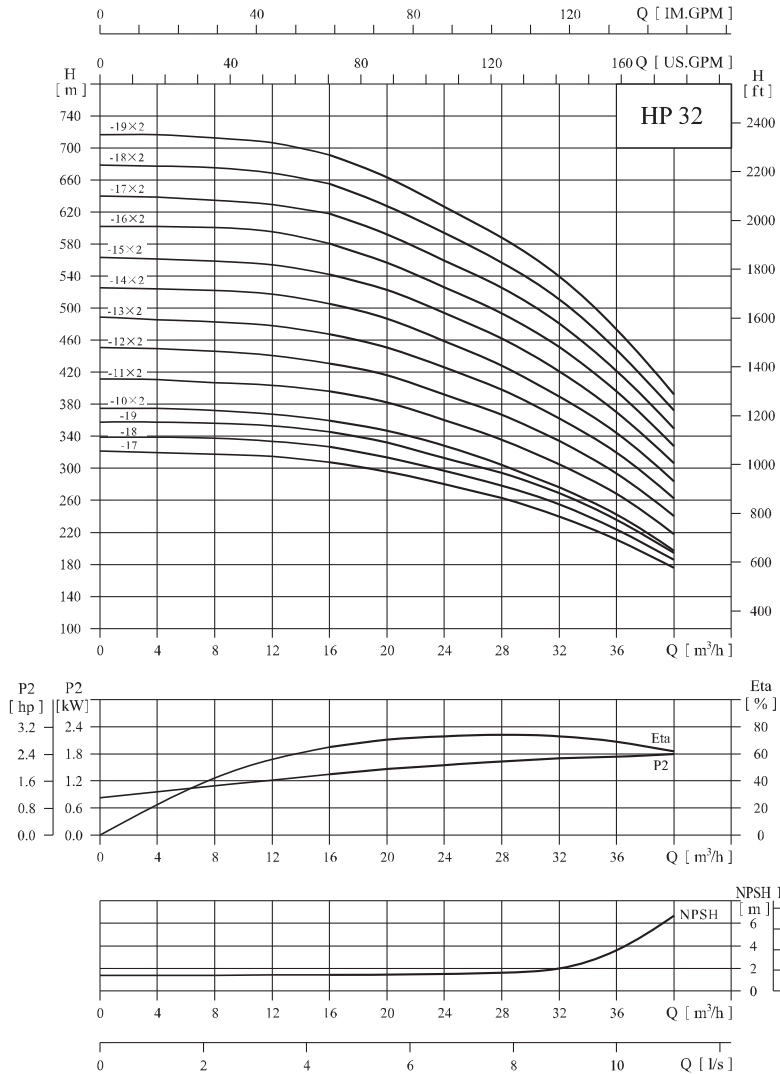

Performance table

Model	Driving motor (kW)	Q (m³/h)	16	20	24	28	32	36	40
HP32-17	37	H (m)	310	295	279	262	240	210	175
HP32-18	37		328	313	296	278	255	222	186
HP32-19	37		346	330	312	293	270	235	197
HP32-10×2	18.5×2		364	348	329	309	276	247	202
HP32-11×2	22×2		401	382	361	339	305	272	220
HP32-12×2	22×2		437	417	394	370	334	296	242
HP32-13×2	30×2		473	452	427	401	363	321	264
HP32-14×2	30×2		510	487	460	432	392	346	287
HP32-15×2	30×2		546	521	493	463	422	371	310
HP32-16×2	30×2		583	556	526	494	452	395	331
HP32-17×2	37×2		619	591	558	525	482	420	352
HP32-18×2	37×2		656	626	591	555	512	445	374
HP32-19×2	37×2		692	660	624	586	542	469	395

Installation sketch

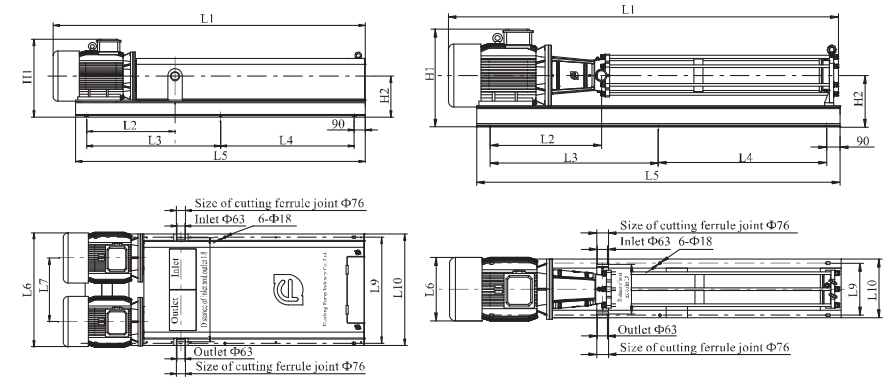

Size and weight

Model	Size (mm)										Weight (kg)		
	L1	L2	L3	L4	L5	L6	L7	L8	L9	L10		H1	H2
HP32-17	2446	734	1040	1040	2260	420		330	340	385	645	340	485
HP32-18	2516	734	1075	1075	2330	420		330	340	385	645	340	490
HP32-19	2586	734	1110	1110	2400	420		330	340	385	645	340	500
HP32-10×2	1856	653	755	755	1689	816	466	796	745	786	550	286	620
HP32-11×2	1956	658	792	792	1764	870	491	821	805	846	575	306	695
HP32-12×2	2026	658	827	827	1834	870	491	821	805	846	575	306	705
HP32-13×2	2166	734	900	900	1980	946	530	860	880	925	645	340	850
HP32-14×2	2236	734	935	935	2050	946	530	860	880	925	645	340	860
HP32-15×2	2306	734	970	970	2120	946	530	860	880	925	645	340	870
HP32-16×2	2376	734	1005	1005	2190	946	530	860	880	925	645	340	880
HP32-17×2	2446	734	1040	1040	2260	946	530	860	880	925	645	340	945
HP32-18×2	2516	734	1075	1075	2330	946	530	860	880	925	645	340	955
HP32-19×2	2586	734	1110	1110	2400	946	530	860	880	925	645	340	965

Performance curve

ISO9906 Annex A 2950rpm

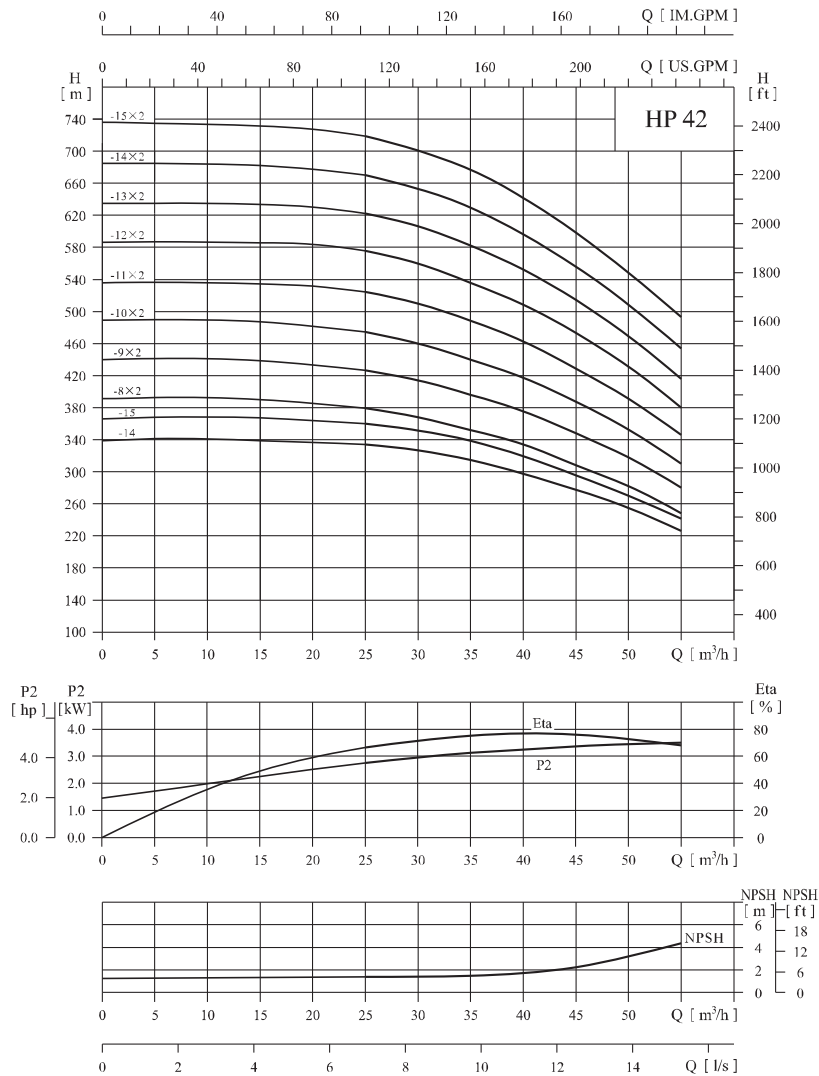

Performance table

Model	Driving motor (kW)	Q (m³/h)	25	30	35	40	42	45	50	55
HP42-14	55	H (m)	336	327	313	298	289	275	253	222
HP42-15	55		360	350	337	319	310	295	271	241
HP42-8×2	30×2		380	373	357	337	324	312	286	252
HP42-9×2	37×2		428	416	400	377	366	350	320	282
HP42-10×2	37×2		476	461	442	418	408	391	358	317
HP42-11×2	45×2		526	513	490	462	450	430	397	348
HP42-12×2	45×2		576	560	536	510	494	472	434	380
HP42-13×2	55×2		624	607	581	553	536	513	470	412
HP42-14×2	55×2		672	652	625	595	578	555	507	443
HP42-15×2	55×2		718	697	670	638	620	597	548	475

Installation sketch

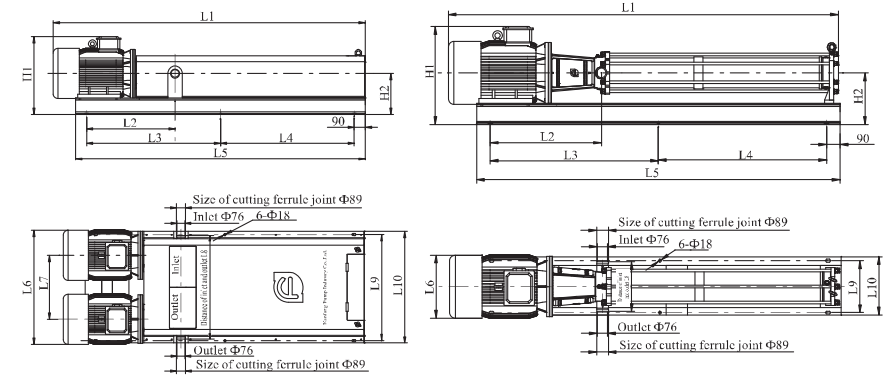

Size and weight

Model	Size (mm)											Weight (kg)	
	L1	L2	L3	L4	L5	L6	L7	L8	L9	L10	H1		H2
HP42-14	2525	868	1078	1078	2333	510		350	432	477	755	390	660
HP42-15	2605	868	1118	1118	2413	510		350	432	477	755	390	665
HP42-8×2	1916	744	777	777	1729	946	530	880	880	925	645	340	815
HP42-9×2	1996	744	817	817	1809	946	530	880	880	925	645	340	895
HP42-10×2	2076	744	857	857	1889	946	530	880	880	925	645	340	905
HP42-11×2	2195	771	910	910	1996	1020	570	920	960	1005	700	365	1040
HP42-12×2	2275	771	950	950	2076	1020	570	920	960	1005	700	365	1055
HP42-13×2	2445	868	1038	1038	2253	1130	620	970	1050	1097	755	390	1270
HP42-14×2	2525	868	1078	1078	2333	1130	620	970	1050	1097	755	390	1285
HP42-15×2	2605	868	1118	1118	2413	1130	620	970	1050	1097	755	390	1295

Performance curve

ISO9906 Annex A 3500rpm

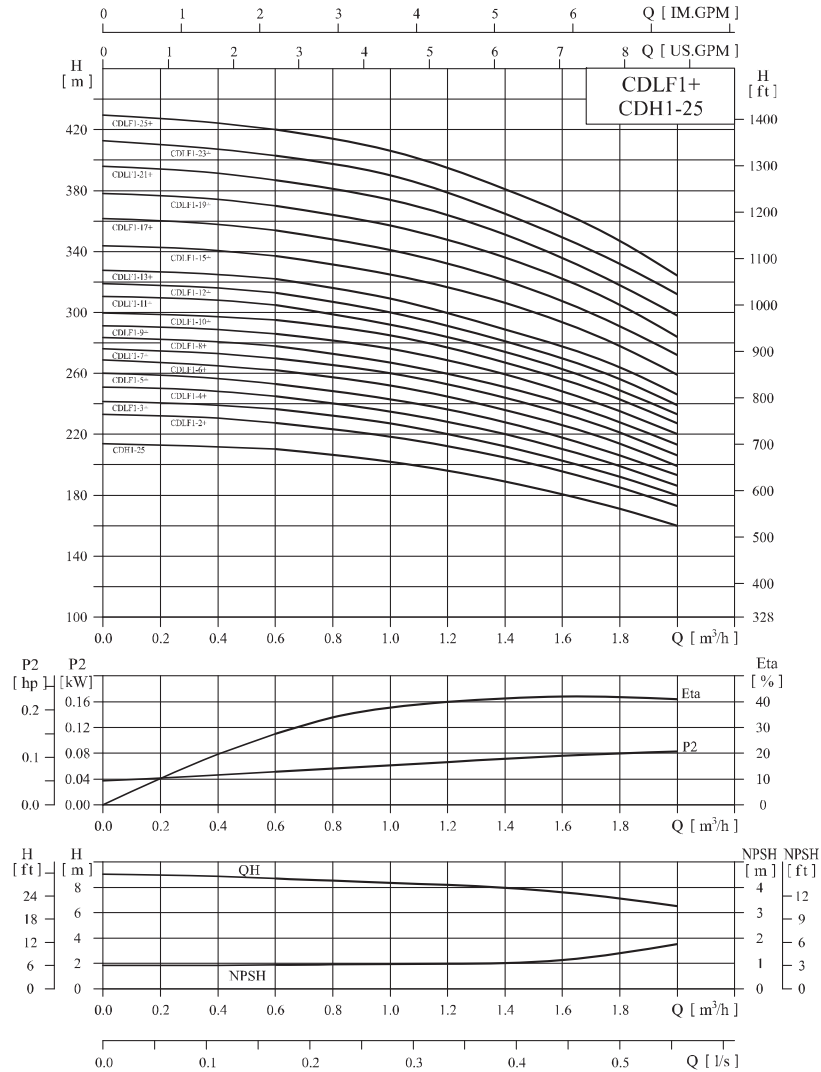

Performance table

Model	Driving motor (kw)	Q (m³/h)	0.6	0.8	1	1.2	1.4	1.6	1.8	2
CDLF1-2+CDH1-25	0.37+3.0	H (m)	227.5	224	218.5	212	204.5	196	185	173
CDLF1-3+CDH1-25	0.37+3.0		236.5	233	227	220	212	203	192	180
CDLF1-4+CDH1-25	0.37+3.0		245	241	235	228	220	211	199	186
CDLF1-5+CDH1-25	0.55+3.0		253	249	243	236	228	219	206	193
CDLF1-6+CDH1-25	0.55+3.0		262	258	252	244	236	226	214	199
CDLF1-7+CDH1-25	0.75+3.0		270	266	260	252	244	233	221	206
CDLF1-8+CDH1-25	0.75+3.0		278	274	267	260	251	240	228	213
CDLF1-9+CDH1-25	0.75+3.0		286	282	276	269	260	247	235	220
CDLF1-10+CDH1-25	1.1+3.0		295	291	285	277	267	255	243	227
CDLF1-11+CDH1-25	1.1+3.0		305	300	292	283	274	262	249	233
CDLF1-12+CDH1-25	1.1+3.0		313	309	300	292	281	269	257	239
CDLF1-13+CDH1-25	1.1+3.0		322	317	309	301	289	276	264	246
CDLF1-15+CDH1-25	1.5+3.0		337	332	325	317	306	293	278	259
CDLF1-17+CDH1-25	1.5+3.0		354	348	341	333	321	305	291	272
CDLF1-19+CDH1-25	2.2+3.0		370	364	357	349	336	322	305	284
CDLF1-21+CDH1-25	2.2+3.0		387	381	374	364	351	334	318	298
CDLF1-23+CDH1-25	2.2+3.0		403	397	390	380	363	348	332	312
CDLF1-25+CDH1-25	3.0+3.0		420	414	407	398	381	365	347	324

Installation sketch

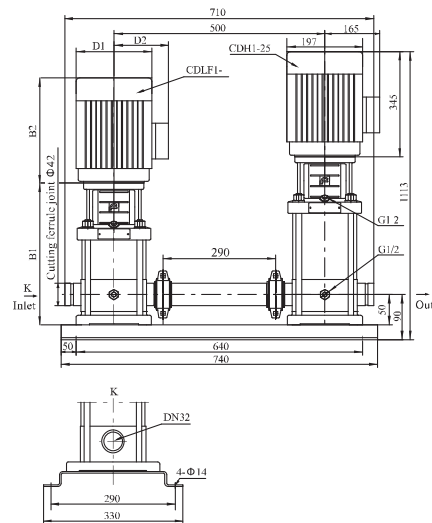

Size and weight

Model	Size (mm)					Weight (kg)
	B1	B2	B1+B2	D1	D2	
CDLF1-2+CDH1-25	258	225	483	148	117	81
CDLF1-3+CDH1-25	276	225	501	148	117	81
CDLF1-4+CDH1-25	294	225	519	148	117	81
CDLF1-5+CDH1-25	312	225	537	148	117	83
CDLF1-6+CDH1-25	330	225	555	148	117	83
CDLF1-7+CDH1-25	358	245	603	170	142	86
CDLF1-8+CDH1-25	376	245	621	170	142	86
CDLF1-9+CDH1-25	394	245	639	170	142	86
CDLF1-10+CDH1-25	412	245	657	170	142	89
CDLF1-11+CDH1-25	430	245	675	170	142	89
CDLF1-12+CDH1-25	448	245	693	170	142	89
CDLF1-13+CDH1-25	466	245	711	170	142	89
CDLF1-15+CDH1-25	512	290	802	190	155	91
CDLF1-17+CDH1-25	548	290	838	190	155	91
CDLF1-19+CDH1-25	584	290	874	190	155	96
CDLF1-21+CDH1-25	620	290	910	190	155	96
CDLF1-23+CDH1-25	656	290	946	190	155	101
CDLF1-25+CDH1-25	702	345	1047	197	165	106

Performance curve

ISO9906 Annex A 3500rpm

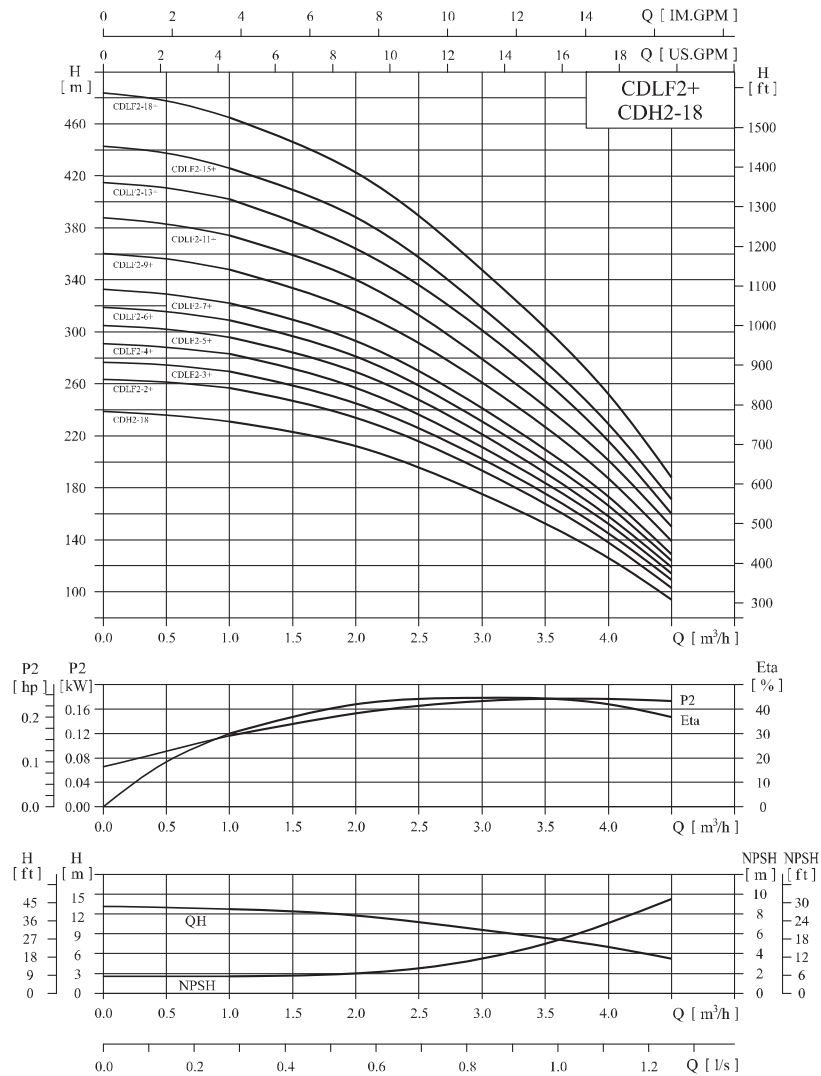

Performance table

Model	Driving motor (kW)	Q (m³/h)	1.0	1.5	2.0	2.5	3.0	3.5	4.0	4.5
CDLF2-2+CDH2-18	0.55+4.0	H (m)	257	248	234	216	193	169	138	103
CDLF2-3+CDH2-18	0.75+4.0		270	260	245	226	202	177	145	109
CDLF2-4+CDH2-18	1.1+4.0		283	272	257	237	211	185	152	114
CDLF2-5+CDH2-18	1.1+4.0		296	284	269	247	221	194	158	119
CDLF2-6+CDH2-18	1.1+4.0		309	298	281	258	231	202	166	124
CDLF2-7+CDH2-18	1.5+4.0		322	310	293	269	241	210	173	129
CDLF2-9+CDH2-18	2.2+4.0		348	335	316	290	261	228	187	139
CDLF2-11+CDH2-18	2.2+4.0		374	360	340	311	279	243	201	150
CDLF2-13+CDH2-18	3.0+4.0		402	387	364	334	301	261	216	160
CDLF2-15+CDH2-18	3.0+4.0		426	410	388	355	317	278	229	171
CDLF2-18+CDH2-18	4.0+4.0		465	452	424	390	346	304	252	188

Installation sketch

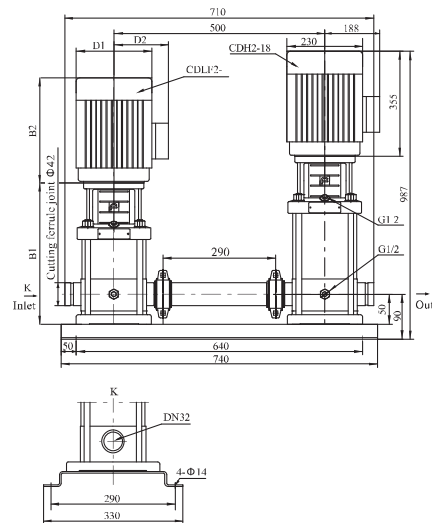

Size and weight

Model	Size (mm)					Weight (kg)
	B1	B2	B1+B2	D1	D2	
CDLF2-2+CDH2-18	258	225	483	148	117	86
CDLF2-3+CDH2-18	286	245	531	170	142	86
CDLF2-4+CDH2-18	304	245	549	170	142	91
CDLF2-5+CDH2-18	322	245	567	170	142	91
CDLF2-6+CDH2-18	340	245	585	170	142	91
CDLF2-7+CDH2-18	368	290	658	190	155	96
CDLF2-9+CDH2-18	404	290	694	190	155	101
CDLF2-11+CDH2-18	440	290	730	190	155	101
CDLF2-13+CDH2-18	486	345	831	197	165	109
CDLF2-15+CDH2-18	522	345	867	197	165	111
CDLF2-18+CDH2-18	576	355	931	230	188	116

Performance curve

ISO9906 Annex A 3500rpm

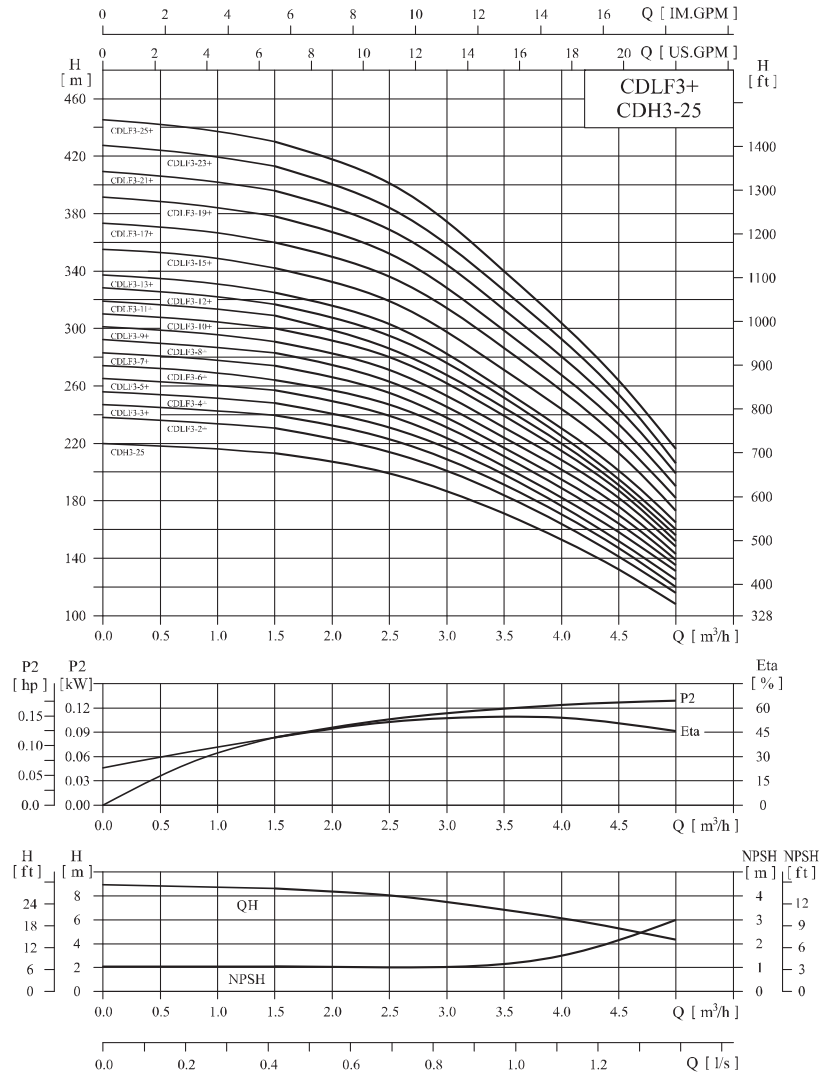

Performance table

Model	Driving motor (kw)	Q (m³/h)	1.5	2.0	2.5	3.0	3.5	4.0	4.5	5.0
CDLF3-2+CDH3-25	0.37+4.0	H (m)	230.5	224	214	200	184	164	141	116
CDLF3-3+CDH3-25	0.55+4.0		239.5	233	223	209	191	171	147	120
CDLF3-4+CDH3-25	0.55+4.0		248	242	231	216	198	178	152	125
CDLF3-5+CDH3-25	0.75+4.0		257	250	239	224	204	184	158	131
CDLF3-6+CDH3-25	1.1+4.0		264	258	247	231	211	190	164	135
CDLF3-7+CDH3-25	1.1+4.0		274	267	255	238	217	196	170	139
CDLF3-8+CDH3-25	1.1+4.0		283	275	263	247	224	202	176	143
CDLF3-9+CDH3-25	1.5+4.0		291	285	271	254	231	209	182	148
CDLF3-10+CDH3-25	1.5+4.0		300	292	280	262	239	216	187	152
CDLF3-11+CDH3-25	1.5+4.0		309	300	286	268	245	222	191	156
CDLF3-12+CDH3-25	2.2+4.0		317	308	295	276	250	226	195	160
CDLF3-13+CDH3-25	2.2+4.0		325	317	303	284	257	233	201	165
CDLF3-15+CDH3-25	2.2+4.0		342	334	319	298	270	246	213	173
CDLF3-17+CDH3-25	2.2+4.0		360	351	336	314	285	259	223	182
CDLF3-19+CDH3-25	3.0+4.0		378	368	352	328	297	271	234	190
CDLF3-21+CDH3-25	3.0+4.0		396	386	369	346	312	282	244	199
CDLF3-23+CDH3-25	3.0+4.0		413	402	384	360	325	295	254	206
CDLF3-25+CDH3-25	4.0+4.0		430	419	401	373	338	307	266	216

Installation sketch

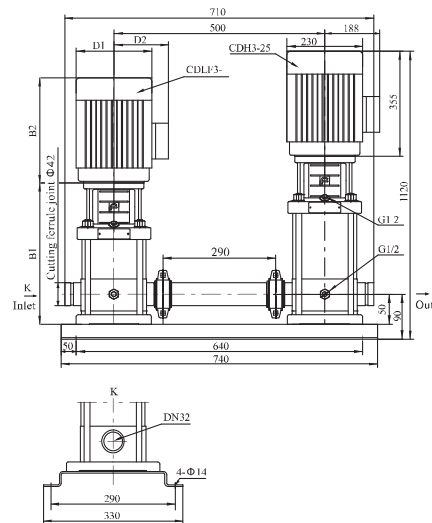

Size and weight

Model	Size (mm)					Weight (kg)
	B1	B2	B1+B2	D1	D2	
CDLF3-2+CDH3-25	258	225	483	148	117	86
CDLF3-3+CDH3-25	276	225	501	148	117	86
CDLF3-4+CDH3-25	294	225	519	148	117	86
CDLF3-5+CDH3-25	322	245	567	170	142	88
CDLF3-6+CDH3-25	340	245	585	170	142	91
CDLF3-7+CDH3-25	358	245	603	170	142	91
CDLF3-8+CDH3-25	376	245	621	170	142	91
CDLF3-9+CDH3-25	404	290	694	190	155	96
CDLF3-10+CDH3-25	422	290	712	190	155	96
CDLF3-11+CDH3-25	440	290	730	190	155	96
CDLF3-12+CDH3-25	458	290	748	190	155	101
CDLF3-13+CDH3-25	476	290	766	190	155	101
CDLF3-15+CDH3-25	512	290	802	190	155	101
CDLF3-17+CDH3-25	548	290	838	190	155	101
CDLF3-19+CDH3-25	594	345	939	197	165	106
CDLF3-21+CDH3-25	630	345	975	197	165	106
CDLF3-23+CDH3-25	666	345	1011	197	165	106
CDLF3-25+CDH3-25	702	355	1057	230	188	116

● Performance curve

ISO9906 Annex A 3500rpm

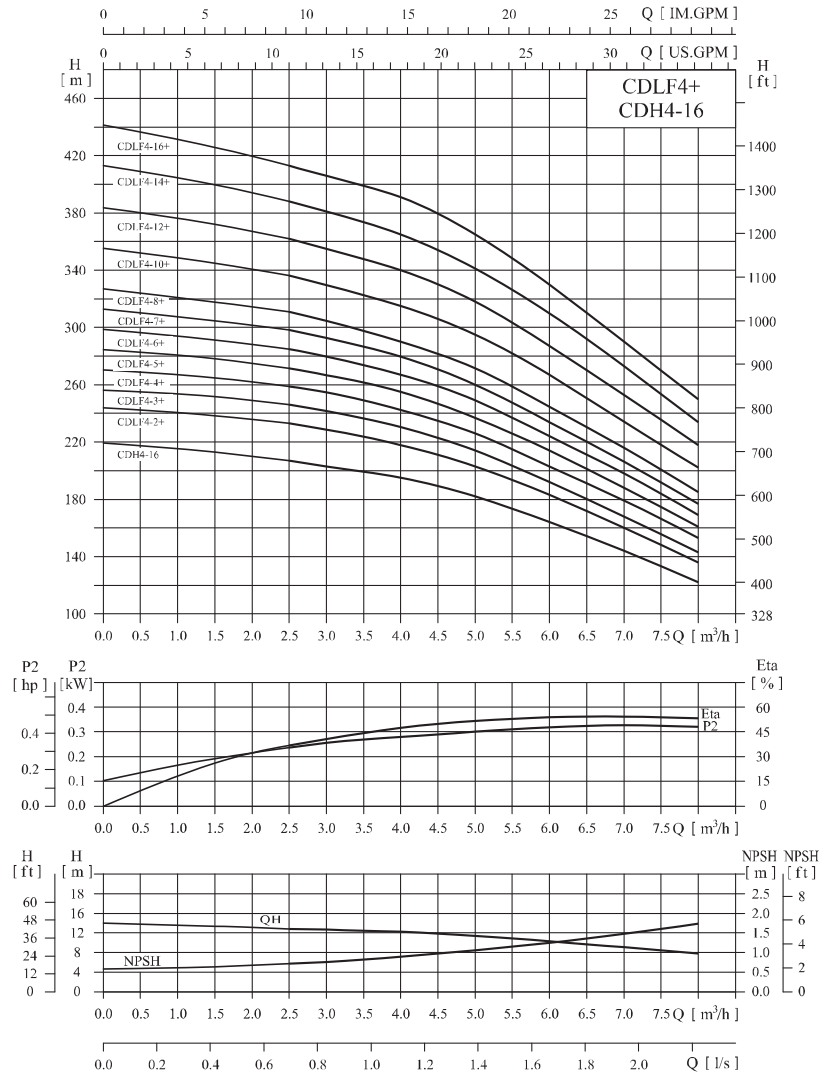

● Performance table

Model	Driving motor (kW)	Q (m³/h)	2.5	3.0	4.0	5.0	6.0	7.0	8.0
CDLF4-2+CDH4-16	0.75+5.5	H (m)	233	229	218	203	184	160	136
CDLF4-3+CDH4-16	1.1+5.5		246	242	231	214	193	168	143
CDLF4-4+CDH4-16	1.5+5.5		259	254	243	226	203	179	153
CDLF4-5+CDH4-16	2.2+5.5		272	266	255	237	214	188	161
CDLF4-6+CDH4-16	2.2+5.5		285	279	267	249	224	198	169
CDLF4-7+CDH4-16	3+5.5		299	292	279	260	234	206	177
CDLF4-8+CDH4-16	3+5.5		311	304	290	272	244	216	185
CDLF4-10+CDH4-16	4+5.5		337	329	315	295	267	234	202
CDLF4-12+CDH4-16	4+5.5		363	354	340	318	287	253	218
CDLF4-14+CDH4-16	5.5+5.5		389	380	365	341	310	273	234
CDLF4-16+CDH4-16	5.5+5.5		414	405	391	365	330	290	250

● Installation sketch

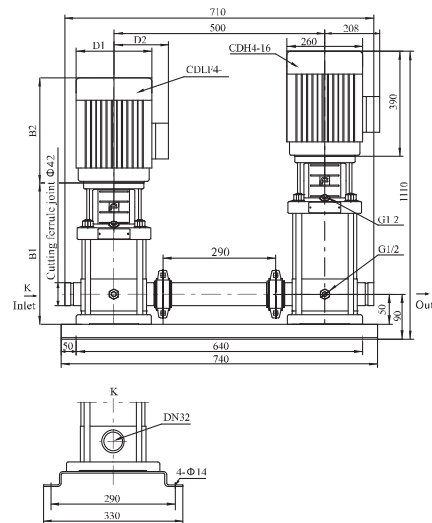

● Size and weight

Model	Size (mm)					Weight (kg)
	B1	B2	B1+B2	D1	D2	
CDLF4-2+CDH4-16	286	245	531	170	142	106
CDLF4-3+CDH4-16	313	245	558	170	142	106
CDLF4-4+CDH4-16	350	290	640	190	155	111
CDLF4-5+CDH4-16	376	290	666	190	155	116
CDLF4-6+CDH4-16	404	290	694	190	155	121
CDLF4-7+CDH4-16	441	345	786	197	165	126
CDLF4-8+CDH4-16	468	345	813	197	165	126
CDLF4-10+CDH4-16	522	355	877	230	188	131
CDLF4-12+CDH4-16	576	355	931	230	188	131
CDLF4-14+CDH4-16	650	390	1040	260	208	156
CDLF4-16+CDH4-16	704	390	1094	260	208	156

Performance curve

ISO9906 Annex A 3500rpm

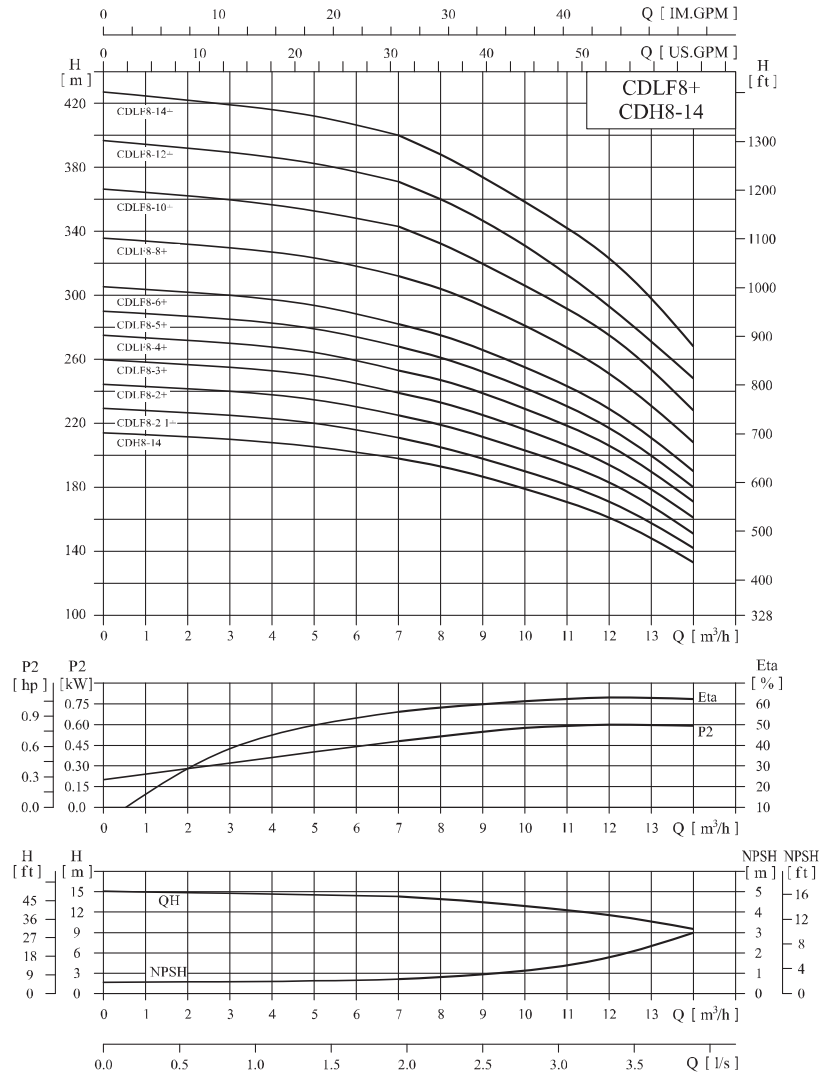

Performance table

Model	Driving motor (kW)	Q (m³/h)	7	8	9	10	11	12	13	14
CDLF8-2/1+CDH8-14	0.75+11	H (m)	211	205	198.5	190	180.5	171	157.5	142
CDLF8-2+CDH8-14	1.5+11		225	219	212	203	193	183	168	151
CDLF8-3+CDH8-14	2.2+11		239	233	225	216	205	194	178	161
CDLF8-4+CDH8-14	3+11		253	247	239	229	217	206	189	171
CDLF8-5+CDH8-14	3+11		268	261	252	242	229	217	200	180
CDLF8-6+CDH8-14	4+11		283	275	265	255	242	229	210	190
CDLF8-8+CDH8-14	5.5+11		313	303	292	280	267	252	232	208
CDLF8-10+CDH8-14	7.5+11		343	333	319	305	292	276	253	228
CDLF8-12+CDH8-14	7.5+11		371	360	347	331	317	293	273	248
CDLF8-14+CDH8-14	11+11		400	388	375	358	344	324	295	268

Installation sketch

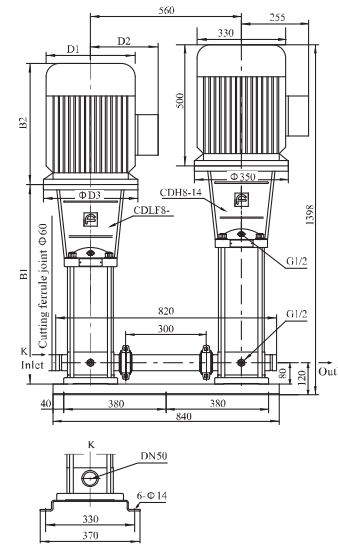

Size and weight

Model	Size (mm)						Weight (kg)
	B1	B2	B1+B2	D1	D2	D3	
CDLF8-2/1+CDH8-14	347	245	592	170	142	145	181
CDLF8-2+CDH8-14	357	290	647	190	155	145	186
CDLF8-3+CDH8-14	387	290	677	190	155	145	191
CDLF8-4+CDH8-14	427	345	772	197	165	160	196
CDLF8-5+CDH8-14	457	345	802	197	165	160	201
CDLF8-6+CDH8-14	487	355	842	230	188	160	206
CDLF8-8+CDH8-14	567	390	957	260	208	200	231
CDLF8-10+CDH8-14	627	390	1017	260	208	200	241
CDLF8-12+CDH8-14	687	390	1077	260	208	200	241
CDLF8-14+CDH8-14	835	500	1335	330	255	350	286

Performance curve

ISO9906 Annex A 3500rpm

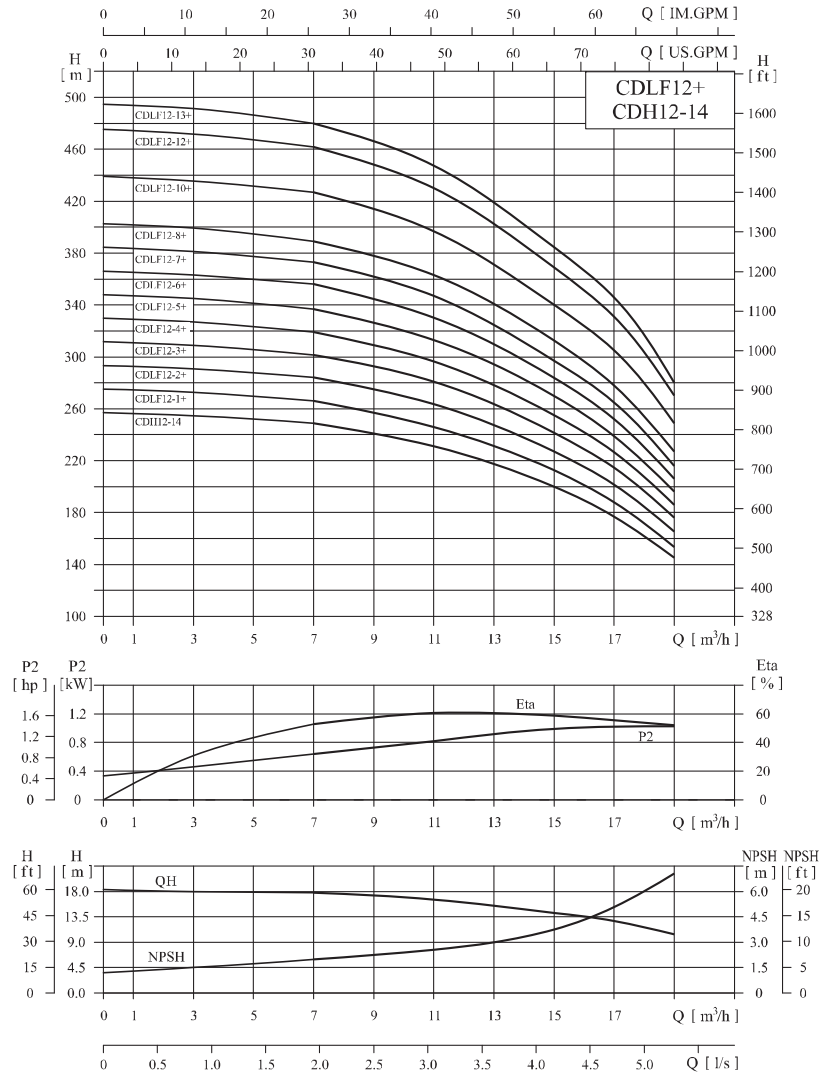

Performance table

Model	Driving motor (kW)	Q (m³/h)	7	9	11	12	13	15	17	19
CDLF12-1+CDH12-14	1.1+15	H (m)	266	258	248	239.5	230	210.5	191	153.5
CDLF12-2+CDH12-14	2.2+15		284	276	265.5	257	246.5	225	204.5	165.5
CDLF12-3+CDH12-14	4+15		301.5	293.5	283	273	262	239.5	217.5	176
CDLF12-4+CDH12-14	5.5+15		319	310	298.5	289	277.5	253	229.5	186
CDLF12-5+CDH12-14	5.5+15		337	328	315	305	293	268	242	196
CDLF12-6+CDH12-14	7.5+15		356	345	332	321	308	282	255	206
CDLF12-7+CDH12-14	7.5+15		373	363	349	337	323	295	268	216
CDLF12-8+CDH12-14	11+15		390	379	365	353	338	309	281	227
CDLF12-10+CDH12-14	11+15		427	415	399	386	369	338	308	249
CDLF12-12+CDH12-14	15+15		462	450	432	418	401	367	334	270
CDLF12-13+CDH12-14	15+15		480	467	449	434	416	381	347	280

Installation sketch

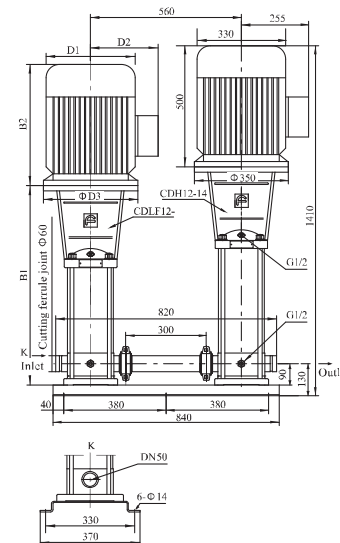

Size and weight

Model	Size (mm)						Weight (kg)
	B1	B2	B1+B2	D1	D2	D3	
CDLF12-1+CDH12-14	357	245	602	170	142	145	214
CDLF12-2+CDH12-14	367	290	657	190	155	145	222
CDLF12-3+CDH12-14	407	355	762	230	188	160	239
CDLF12-4+CDH12-14	457	390	847	260	208	200	256
CDLF12-5+CDH12-14	487	390	877	260	208	200	256
CDLF12-6+CDH12-14	517	390	907	260	208	200	259
CDLF12-7+CDH12-14	547	390	937	260	208	200	259
CDLF12-8+CDH12-14	665	500	1165	330	255	350	329
CDLF12-10+CDH12-14	725	500	1225	330	255	350	331
CDLF12-12+CDH12-14	785	500	1285	330	255	350	344
CDLF12-13+CDH12-14	815	500	1315	330	255	350	345

Performance curve

ISO9906 Annex A 3500rpm

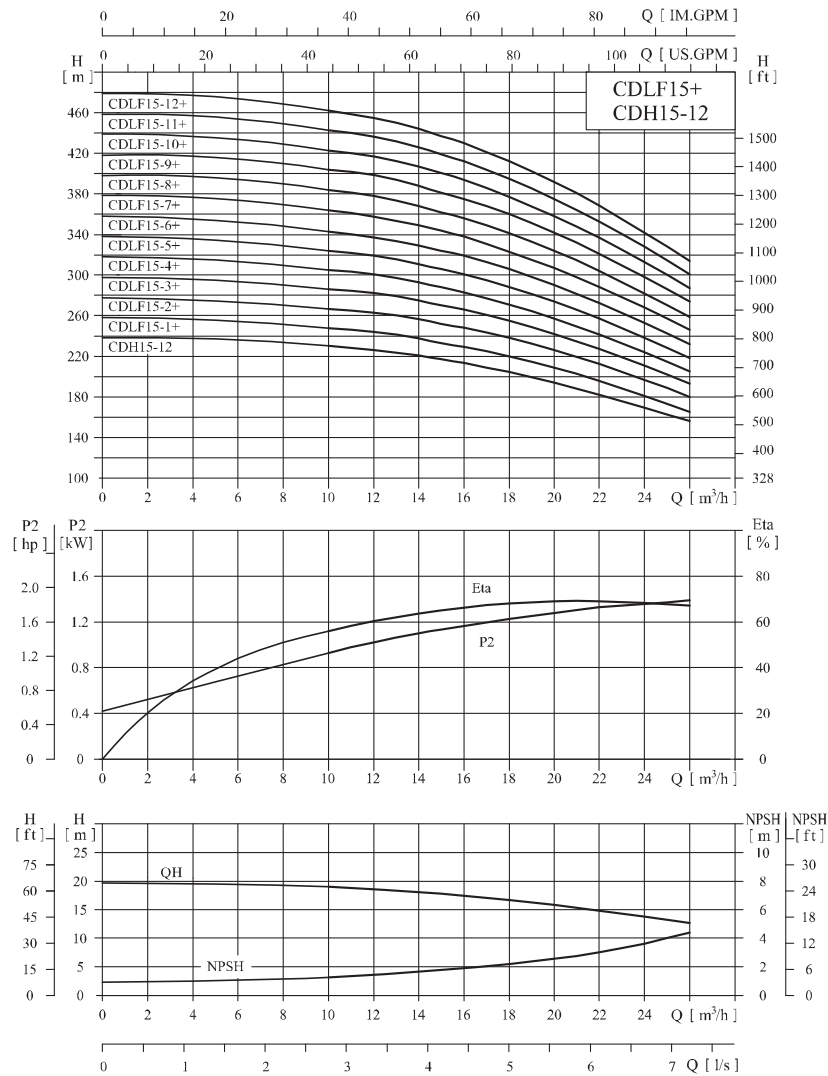

Performance table

Model	Driving motor (kw)	Q (m³/h)	H (m)									
			10	12	14	15	16	18	20	22	24	26
CDLF15-1+CDH15-12	1.5+18.5		247.5	243	237.5	233	229.5	220	209	195.5	181	165.5
CDLF15-2+CDH15-12	3+18.5		266.5	262	256.5	252	248.5	238	226	212	197	180
CDLF15-3+CDH15-12	4+18.5		286	281	275	270	266	255	242	227	211	193
CDLF15-4+CDH15-12	5.5+18.5		305	300	293	288	283	271	257	241	224	205
CDLF15-5+CDH15-12	7.5+18.5		324	318	311	305	301	288	274	257	238	218
CDLF15-6+CDH15-12	11+18.5		343	337	329	324	319	306	290	272	253	232
CDLF15-7+CDH15-12	11+18.5		364	357	349	343	338	323	307	288	268	246
CDLF15-8+CDH15-12	11+18.5		384	377	368	361	356	341	324	304	282	259
CDLF15-9+CDH15-12	11+18.5		404	397	388	381	375	360	342	321	298	274
CDLF15-10+CDH15-12	15+18.5		423	416	407	399	394	377	358	337	313	287
CDLF15-12+CDH15-12	18.5+18.5		462	454	444	436	430	412	392	368	342	314

Installation sketch

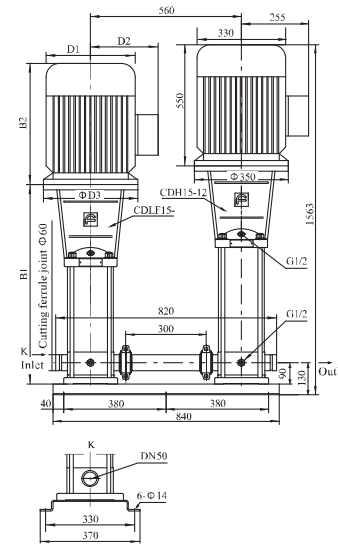

Size and weight

Model	Size (mm)						Weight (kg)
	B1	B2	B1+B2	D1	D2	D3	
CDLF15-1+CDH15-12	397	290	687	190	155	145	248
CDLF15-2+CDH15-12	407	345	752	197	165	160	258
CDLF15-3+CDH15-12	452	355	807	230	188	160	267
CDLF15-4+CDH15-12	517	390	907	260	208	200	280
CDLF15-5+CDH15-12	562	390	952	260	255	200	290
CDLF15-6+CDH15-12	695	390	1085	330	255	350	359
CDLF15-7+CDH15-12	740	390	1130	330	255	350	361
CDLF15-8+CDH15-12	785	390	1175	330	255	350	362
CDLF15-9+CDH15-12	830	390	1220	330	255	350	374
CDLF15-10+CDH15-12	875	500	1375	330	255	350	376
CDLF15-12+CDH15-12	965	550	1515	330	255	350	400

Performance curve

ISO9906 Annex A 3500rpm

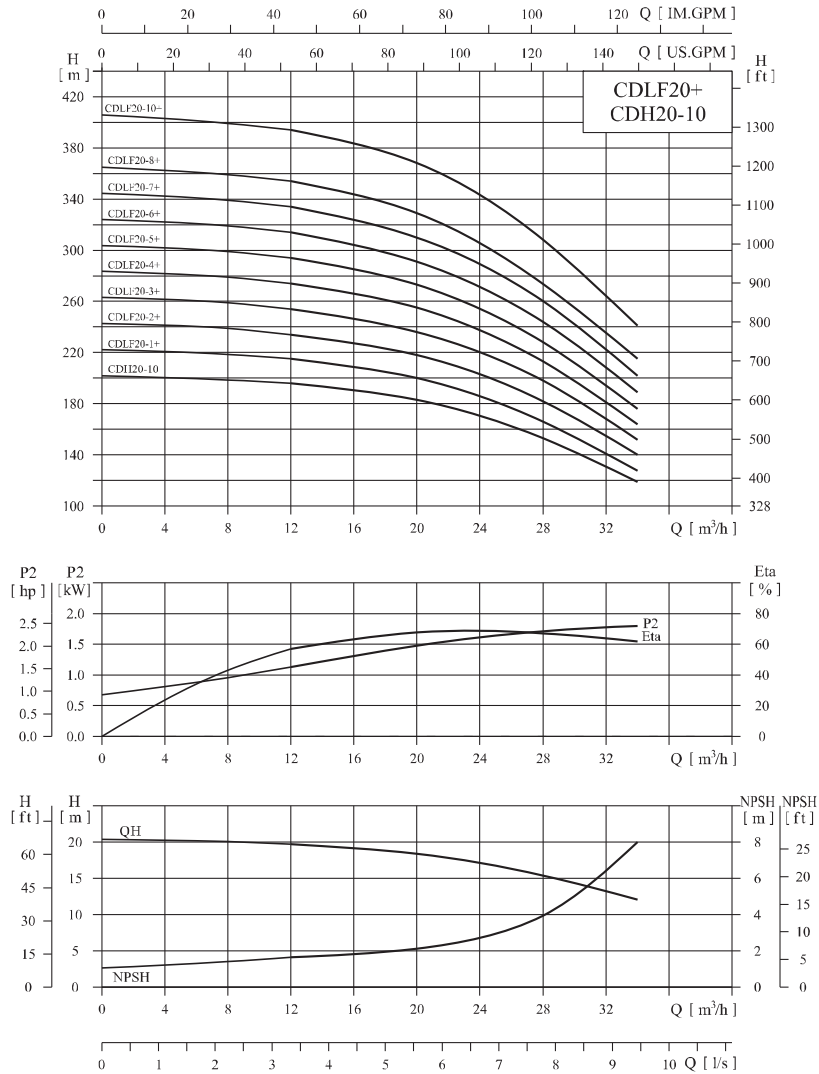

Performance table

Model	Driving motor (kW)	Q (m³/h)	12	16	20	24	28	32	34
CDLF20-1+CDH20-10	2.2+18.5	H (m)	215	209	200	185	166	141	127.5
CDLF20-2+CDH20-10	4+18.5		234	228	218	202	182	155	140
CDLF20-3+CDH20-10	5.5+18.5		254	247	236	220	198	169	152
CDLF20-4+CDH20-10	7.5+18.5		274	266	255	237	213	182	164
CDLF20-5+CDH20-10	11+18.5		294	285	273	255	228	195	176
CDLF20-6+CDH20-10	11+18.5		314	304	291	272	244	208	189
CDLF20-7+CDH20-10	15+18.5		334	324	310	289	260	222	202
CDLF20-8+CDH20-10	15+18.5		354	344	329	307	276	236	215
CDLF20-10+CDH20-10	18.5+18.5		394	384	368	342	308	264	241

Installation sketch

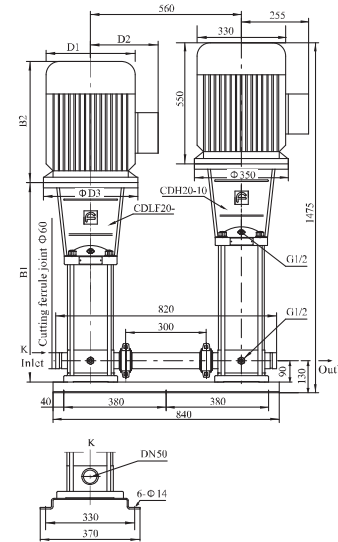

Size and weight

Model	Size (mm)						Weight (kg)
	B1	B2	B1+B2	D1	D2	D3	
CDLF20-1+CDH20-10	397	290	687	190	155	145	249
CDLF20-2+CDH20-10	407	355	762	230	188	160	259
CDLF20-3+CDH20-10	472	390	862	260	208	200	279
CDLF20-4+CDH20-10	517	390	907	260	208	200	289
CDLF20-5+CDH20-10	650	500	1150	330	255	350	349
CDLF20-6+CDH20-10	695	500	1195	330	255	350	354
CDLF20-7+CDH20-10	740	500	1240	330	255	350	369
CDLF20-8+CDH20-10	785	500	1285	330	255	350	369
CDLF20-10+CDH20-10	875	550	1425	330	255	350	392

● Performance curve

ISO9906 Annex A 3540rpm

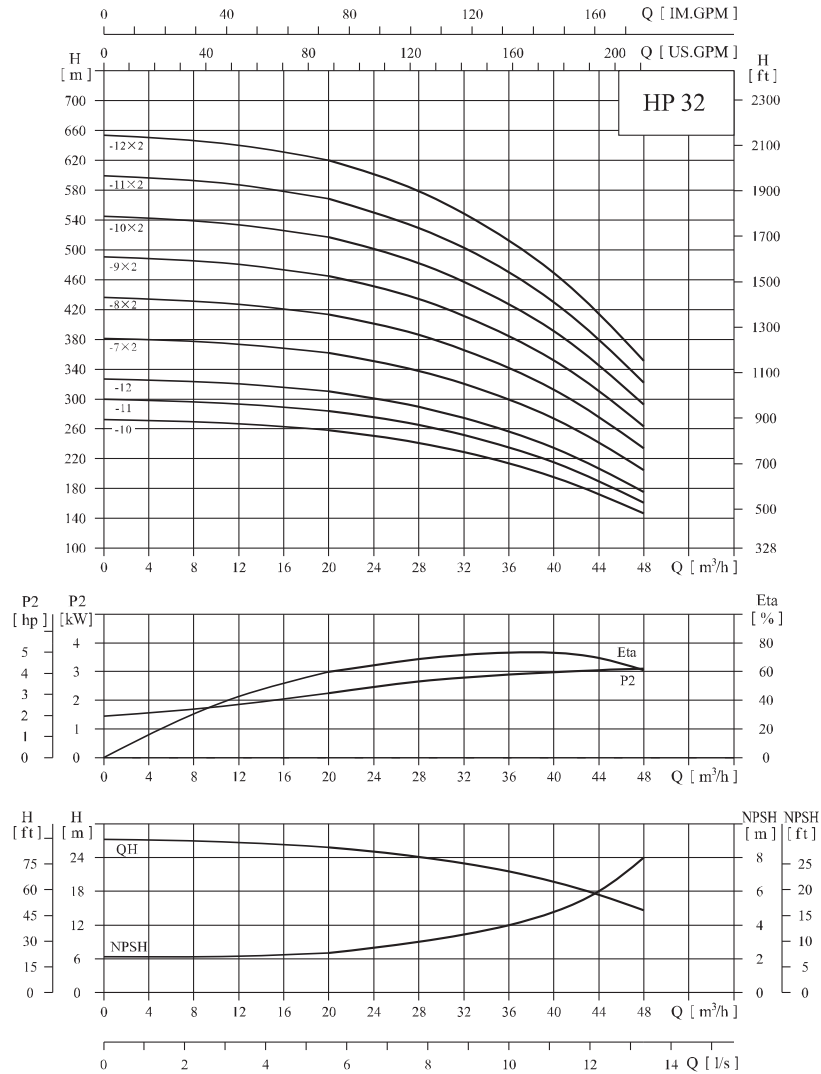

● Performance table

Model	Driving motor (kW)	Q (m³/h)	20	24	28	32	36	40	44	48
HP32-10	37	H (m)	258	252	241	229	216	196	173	146
HP32-11	37		284	277	266	252	236	215	191	161
HP32-12	37		310	302	290	275	258	235	209	176
HP32-7×2	22×2		362	352	338	320	301	274	243	205
HP32-8×2	30×2		413	402	386	366	344	313	278	234
HP32-9×2	30×2		465	453	435	412	387	352	313	263
HP32-10×2	37×2		517	503	483	458	430	391	348	293
HP32-11×2	37×2		568	553	531	504	473	430	383	322
HP32-12×2	37×2		620	604	579	549	516	469	417	351

● Installation sketch

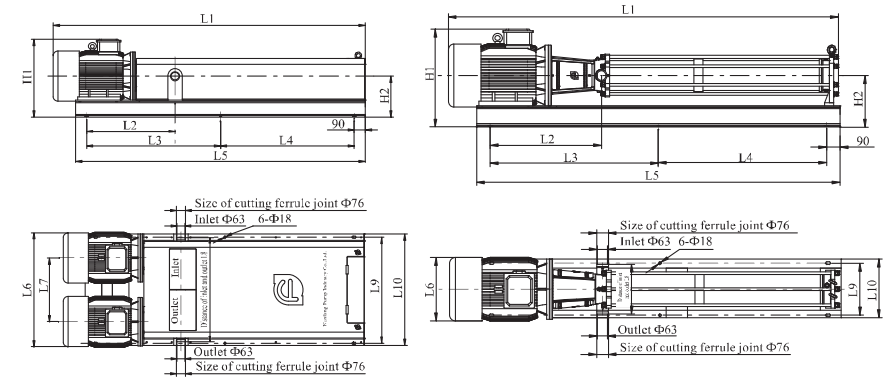

● Size and weight

Model	Size (mm)										Weight (kg)		
	L1	L2	L3	L4	L5	L6	L7	L8	L9	L10		H1	H2
HP32-10	1956	734	795	795	1770	420		330	340	385	625	320	440
HP32-11	2026	734	830	830	1840	420		330	340	385	625	320	445
HP32-12	2096	734	865	865	1910	420		340	340	385	625	320	450
HP32-7×2	1676	658	652	652	1484	870	491	821	805	846	570	300	650
HP32-8×2	1816	734	725	725	1630	946	530	860	880	925	645	340	790
HP32-9×2	1886	734	760	760	1700	946	530	860	880	925	645	340	800
HP32-10×2	1956	734	795	795	1770	946	530	860	880	925	645	340	845
HP32-11×2	2026	734	830	830	1840	946	530	860	880	925	645	340	855
HP32-12×2	2096	734	865	865	1910	946	530	860	880	925	645	340	865

Performance curve

ISO9906 Annex A 3540rpm

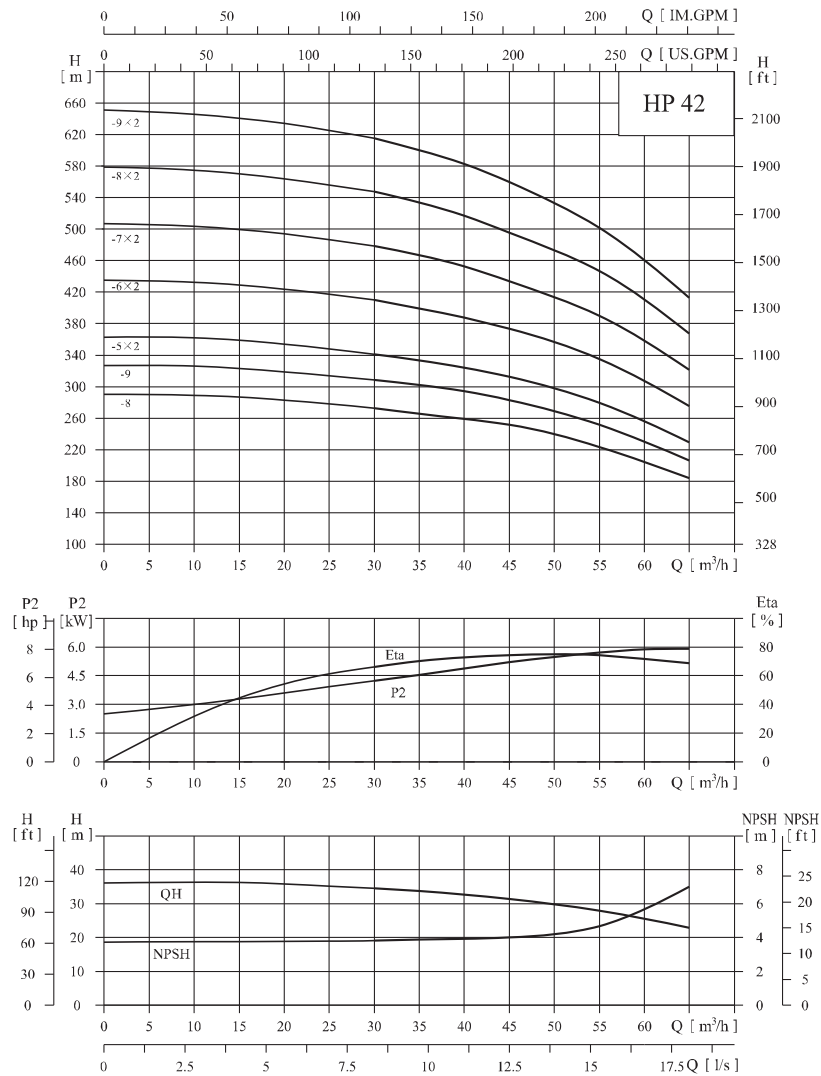

Performance table

Model	Driving motor (kW)	Q (m³/h)	30	35	40	42	45	50	55	60	65
HP42-8	55	H (m)	274	267	258	253	248	236	223	207	184
HP42-9	55		308	301	290	285	279	266	251	232	207
HP42-5×2	30×2		342	334	322	317	310	295	279	258	230
HP42-6×2	37×2		411	401	387	380	371	355	335	310	275
HP42-7×2	45×2		479	468	451	443	433	414	391	362	321
HP42-8×2	55×2		548	534	516	507	495	473	447	413	367
HP42-9×2	55×2		616	601	580	570	557	532	503	465	413

Installation sketch

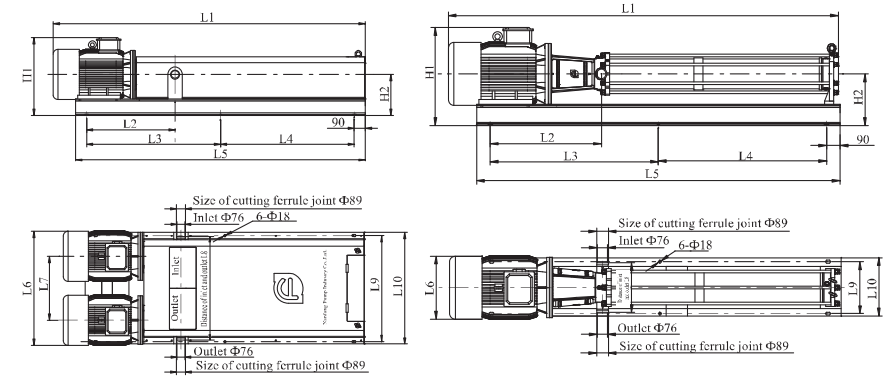

Size and weight

Model	Size (mm)											Weight (kg)	
	L1	L2	L3	L4	L5	L6	L7	L8	L9	L10	H1		H2
HP42-8	2045	868	838	838	1853	510		350	432	477	755	390	615
HP42-9	2125	868	878	878	1933	510		350	432	477	755	390	620
HP42-5×2	1676	744	656.5	656.5	1489	946	530	880	880	925	645	340	765
HP42-6×2	1756	744	696.5	696.5	1569	946	530	880	880	925	645	340	845
HP42-7×2	1875	771	750	750	1676	1020	570	920	960	1005	700	365	970
HP42-8×2	2045	868	838	838	1853	1130	620	970	1050	1097	755	390	1180
HP42-9×2	2125	868	878	878	1933	1130	620	970	1050	1097	755	390	1190

