



SelfAct™

Selfacting Control Valve

PN 10 - 40 , DN 15 - 200



Experience In Motion

Application

Self-actuating Pressure Reducing Valves are used to provide a constant pressure **downstream** of its built-in position. Suitable for steam, non inflammable vapours and gases and neutral liquids.

Product features

Body shape gives optimum flow characteristic

- Excellent flow dynamics when correctly selected
- Heavy top guided plug
- Largest possible kvs-values
- High degree of accuracy in the outlet pressure by carefully selected springs

Long service life and operational reliability

- Maintenance free
- Strong guide, giving minimum vibration and wear
- The valve stem is sealed by a CrNi-steel bellows which is also used to pressure balance the valve

Replaceable trim

- Simple maintenance as the valve body remains in the piping when trim is replaced
- Screwed seat

Wide range of application

- Up to 6 adjustment ranges are available per size
- Easy control point setting by the handwheel at any time

Quick delivery

- **SELF**ACT Valves can be delivered within one week

Quality assurance system certified acc. EN ISO 9001 : 2000 including product development.

Schmidt minimal Valve Standards acc. to the Pressure Equipment Directive 97/23/EC Modul H

Pressure Reducing Valve

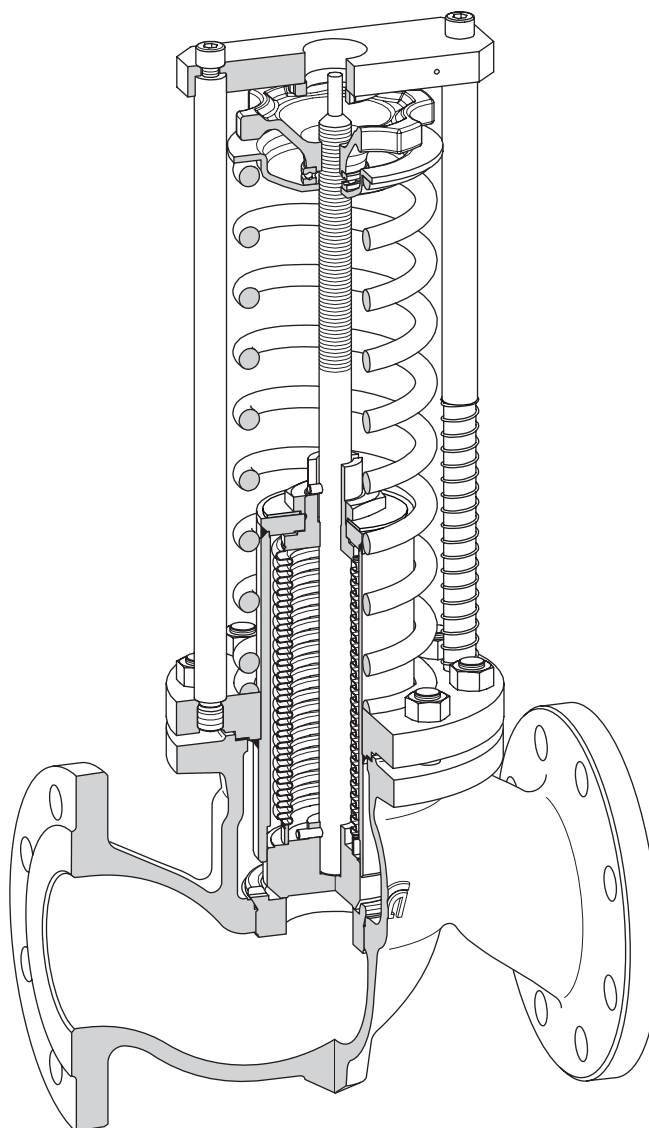
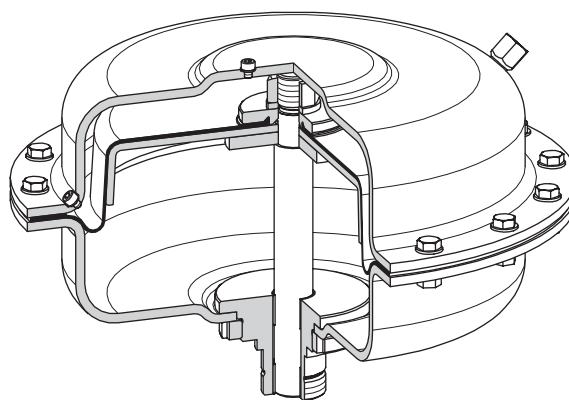

The Pressure Reducing Valve consists in the main of: Body with the Trim, Bellows and Actuator and > 100 °C a water Seal Tank.

Body with Flange Connection

Type	Material	Atteste		Nominal Size DN												
		without	with	15	20	25	32	40	50	65	80	100	125	150	200	
Pressure Reducing Valve	0.7043	Material resp. Pressure/Leakage Certificate Schmidt minimal Valve Standard acc. to Pressure Equipment Directive 97/23EC Kat. II	Pressure resp. Leakage Certificate acc. to EN 10 204 - 2.2, 3.1B	•	•	•	•	•	•	•	•	•	•	•	•	•
	1.0619			•	•	•	•	•	•	•	•	•	•	•	•	•
	1.4581			•	•	•	•	•	•	•	•	•	•	•	•	•

Form of Connection, Nominal Pressure Range

Form of Connection			Material	PN	Nominal Size DN											
					15	20	25	32	40	50	65	80	100	125	150	200
Flanges acc. to DIN 2526	Form C	•	0.7043	10						•	•	•	•	•		
		•		16	•	•	•	•	•		•	•	•	•	•	
		•		25							•	•	•	•	•	•
	Form C	•	1.0619 1.4581	10												
		•		16	•	•	•	•	•							
		•		25							•	•	•	•	•	•
			40													

Pressure-Temperature Ratings (acc. to DIN 2401)

PN	Body Material	Service Temperature in °C	-85	-60	-10	0	120	200	250	300	350	400	450	500	530
10	0.7043	Working Pressure in bar			10	10	10	8	8	7	6				
	1.0619				10	10	10	8	7	5	4	3			
	1.4581				10	10	8,4	7,3	6,9	6,5	6,1	5,7			
16	0.7043	Working Pressure in bar			16	16	15	13	12	11	10				
	1.0619				16	16	16	14	13	11	10	8			
	1.4581				16	16	13	12	11	10	10	9			
25	0.7043	Working Pressure in bar			25	25	24	20	19	17	16				
	1.0619				25	25	25	22	20	17	16	13			
	1.4581				25	25	21	18	17	16	15	14			
40	1.0619	Working Pressure in bar			40	40	40	35	32	28	24	21			
	1.4581				40	40	34	29	28	26	24	23			

Disk Plug

Characteristic: linear

Kvs (m³/h)	Port Size (mm)	Stroke (mm)	Material/Design 1.4571 standard	Incorporable seat diameter depends on nominal size DN											
				15	20	25	32	40	50	65	80	100	125	150	200
1,8	12	4	•	•	•										
3,0	20	5	•	•											
5,0	20	5	•	•											
8,0	20	5	•		•										
10	20	6	•			•									
15	25	6	•					•							
25	32	8	•						•						
38	40	9	•							•					
59	50	11	•								•				
87	65	12	•									•			
150	86	16	•										•		
204	105	17	•											•	
255	120	18	•												•

Rangeability

Standard Rangeability:	Rangeability 1 : 10
------------------------	---------------------

Leakage-class acc. to DIN 3230 Teil 3

Plug	Plug Design	Leakage-class acc. DIN 3230 - BO	Test Medium	Test Pressure (bar)	max. Seat Leakage in % of kvs
standard	metal-to-metal seated, reseated	Class 1 - tight	Air	Working Pressure, max. 6	0,0 - tight

Actuator Selection

Incorporable Actuator Size depends on Adjustment Range and Nominal Size:

Adjustment Range (bar g)	Nominal Size DN												
	15	20	25	32	40	50	65	80	100	125	150	200	
8 - 20	B11							A11	B2				
8 - 16,5										A11			
3,2 - 10								A2					
2,4 - 10								A11					
1,1 - 10	A11												
1,8 - 4,5								A3					
1,2 - 4,0								A3					
0,8 - 3,0								A3					
0,8 - 2,2								A4					
0,4 - 1,5								A4					
0,4 - 1,1								A51					
0,1 - 1,4	A4												
0,1 - 1,0								A4					
0,1 - 0,6								A51		A6			

Deviation

The characteristics of the Pressure Reducing Valve is like a proportional controller. Their construction therefore has a max. permanent deviation dependent on the nominal size and actuator size.

Actuator Size	max. Deviation in ± bar for Actuator / Nominal Size DN ¹⁾											
	15	20	25	32	40	50	65	80	100	125	150	200
B11	0,23	0,37	0,56	0,64	0,90	1,00	1,92					
B2									1,99			
A11	0,11	0,19	0,29	0,32	0,43	0,43	0,68	1,21		1,75	2,12	2,21
A2								0,59	1,02	1,04	1,27	1,32
A3						0,16	0,23	0,32	0,48	0,65	0,79	0,82
A4	0,02	0,02	0,04	0,04	0,06	0,06	0,08	0,11	0,14	0,24	0,28	0,30
A51								0,05	0,07	0,12	0,14	0,15
A6										0,06	0,08	0,08

Operating Medium Temperature > 100 °C

If the medium temperature is > 100 °C the use of a Seal Tank is essential otherwise the diaphragm of the actuator will be destroyed !

Seal Tank	Nominal Size DN												
	15	20	25	32	40	50	65	80	100	125	150	200	
1	G1												
2								G2					
3										G3			

¹⁾ The actual deviation depends on utilisation of the flow range:

Example DN 125 and actuator A2 -> max. deviation = ± 1,04 bar
 kvs value max. 150 m³/h, actually used kvs value = 111 m³/h -> utilisation = 74 % } the actually deviation = 1,04 x 0,74 = ± 0,77 bar

Installation recommendation

The successful employment of the Pressure Reducing Valve depends directly on a suitable design of the mounting arrangement. As the function of the Pressure Reducing Valve depends greatly on the consideration of the physical possibilities, it is recommended to observe the stated standard values. Deviations may lead to considerable fluctuations in the control loop for which the Pressure Reducing Valve manufacturer rejects any liability whatsoever. In borderline cases, an expensive conversion of the piping should be expected. Even though the physical processes may in individual cases justify a deviation from the standard values, however, this requires a comprehensive system knowledge and the express approval of the manufacturer.

Physical requirements

- Pressure Reducing Valves are used primarily for **steam, non inflammable vapours and gases**. It also has limited use for **neutral liquids**, because the close direction of the plug is in the flow direction of the medium and that can produce vibrations (hammer) at a utilisation for less than 20 %.
- Realistic **rangeability 1 : 10 !**
- At service conditions of **more than 100 °C** it is necessary to protect the diaphragm against overheating by using a **seal tank !**
- Ensure that the outlet velocity for **vapours and gases** is less than **70 m/s** and **liquids and wet steam** is less than **8 m/s**, otherwise the standards for friction loss, wearing, pressure shock and noise of flow will be increase distinctly.
- The safe load **relative differential pressure** depends on nominal size and is for
 - DN 15 - 50 max. **24 bar**
 - DN 65 - 100 max. **20 bar**
 - DN 150 - 200 max. **15 bar**,
 otherwise the trim can be overloaded.

System requirements

- System drawings with design recommendation. Experience shows that deviations result in considerable problems.

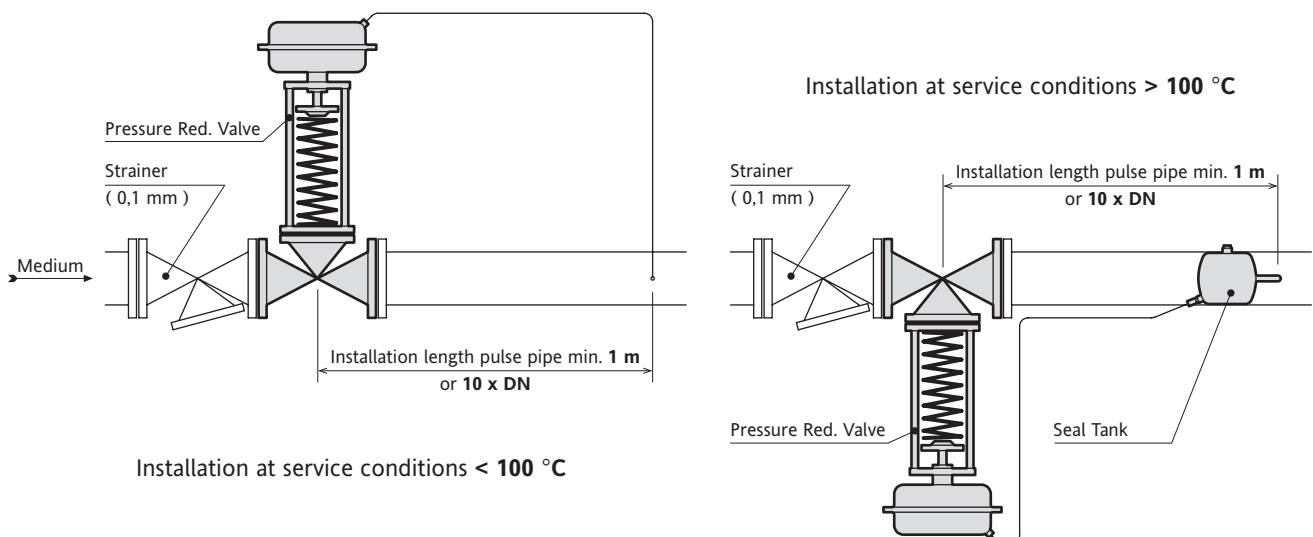

For installing a water seal tank be carefully to place it higher up than the valve actuator !

Installation

- At service conditions **more than 100 °C** pour water into the filler socket of the seal tank until it emerges from the vent without bubbles. Now close the vent screw and continue filling until the water reaches a height of 35 mm below the top level of the filler socket. After closing the filler socket, the pressure reducing valve is ready to work.
- At service conditions **less than 100 °C** and gaseous the pressure reducing valve is ready to work. In case of liquid, the actuator must be filled completely with liquid by using its upper vent screw.

Parts List

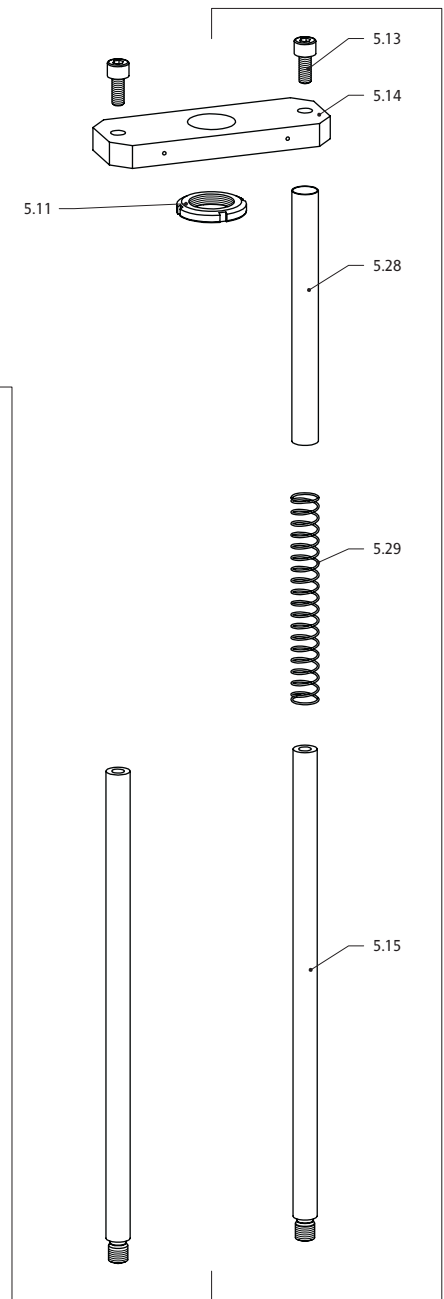
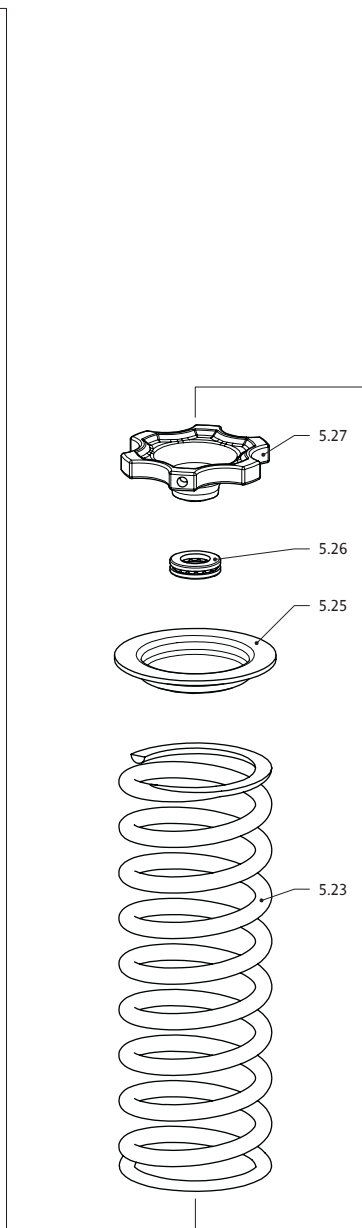
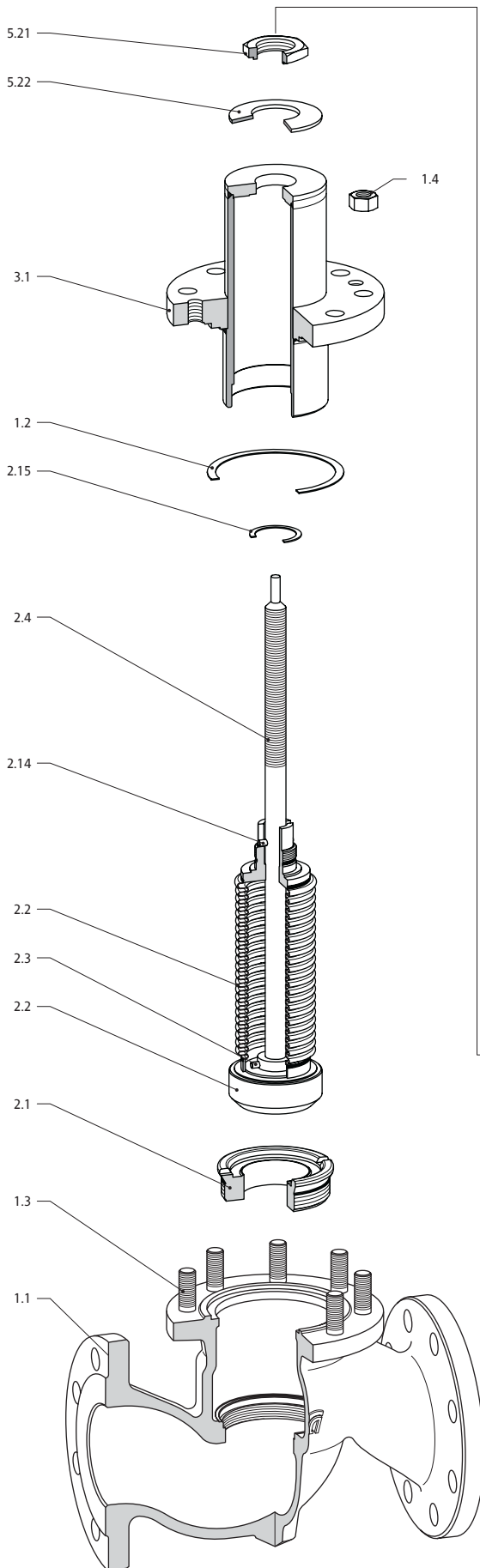

SelfAct™ - Selfacting Control Valve

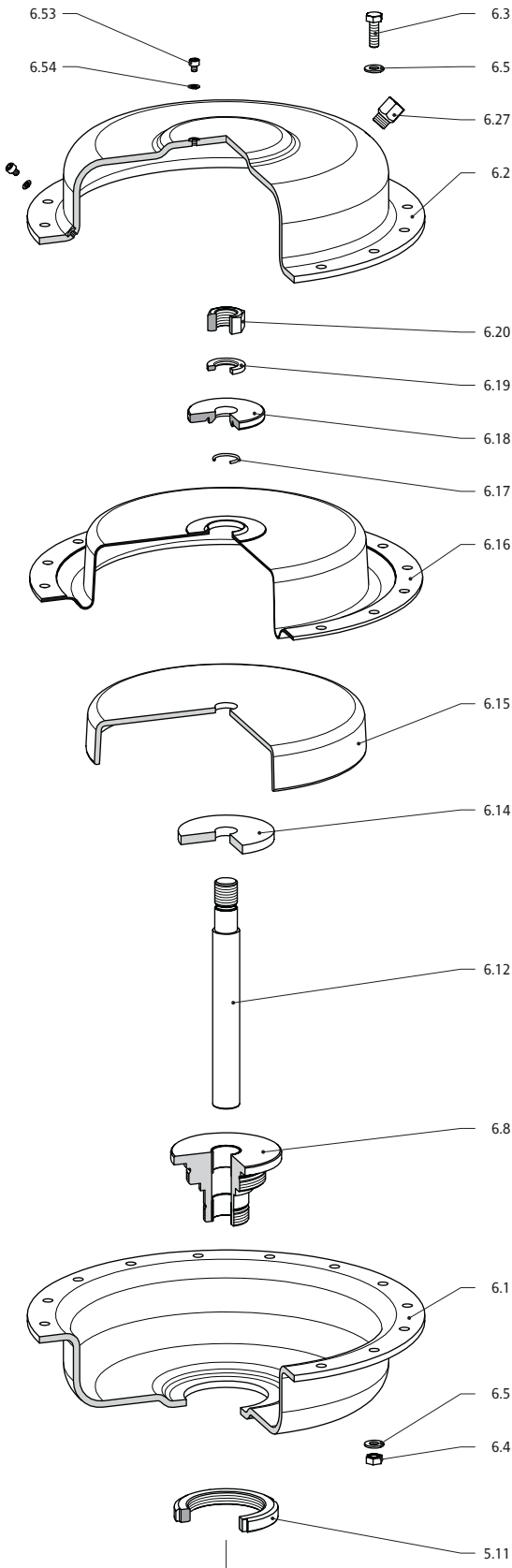

Designation	Part	Materials			Spare Parts
Body	1.1	0.7043	1.0619	1.4581	
Bonnet Gasket	1.2	Pure Graphite on Support Plate from 1.4571			D
Stud Bolt	1.3	YK		A2-70	
Hex Nut	1.4	YK		A2-70	
Screwed Seat	2.1	1.4571			S
Plug / Bellows Unit	2.2	1.4571			K
Straight Pin	2.3	1.4021			
Stem	2.4	1.4021			
Spring Pin	2.14	1.1231			
Gasket	2.15	Pure Graphite on Support Plate from 1.4571			D
Bonnet	3.1	1.0460		1.4571	
Lock Nut, Actuator	5.11	Steel, chromotized			
Cylinder Head Stud	5.13	8.8, chromotized			
Plate	5.14	1.1191, chromotized			
Column	5.15	1.0736, chromotized			
Hex Nut	5.21	1.0501			
Belleville Spring	5.22	1.8159			
Compression Spring	5.23	1.7103, chromotized			
Lower Spring Plate	5.24	Sheet Steel, painted ¹⁾			
Upper Spring Plate	5.25	Sheet Steel, painted			
Ball Bearing	5.26	Chrome Steel			
Hand Wheel	5.27	0.6025, painted			
Setting Scale	5.28	1.0308			
Spring	5.29	1.1191, chromotized			

Lock Nut, Actuator	5.11	Steel, chromotized			
Lower Casing	6.1	1.0332, powder coated			
Upper Casing	6.2	1.0332, powder coated			
Hex Screw	6.3	A2-70			
Hex Nut	6.4	A2-70			
Washer	6.5	A2			
Distance Ring	6.7	1.0460, chromotized ²⁾			
Guide Bush	6.8	1.0460, chromotized / Bronze, Steel			
Actuator Stem	6.12	1.4122			
Washer	6.14	1.0736, chromotized			
Diaphragm Plate	6.15	1.0332, chromotized			
Diaphragm	6.16	NBR			M
O-Ring	6.17	NBR			
Pressure Washer	6.18	1.4305			
Lock Washer	6.19	A2			
Hex Nut	6.20	A2-70			
Diaphragm Plate Ring	6.52	1.0460 ²⁾			
Lock Screw	6.53	A2-70			
Gasket	6.54	Aramide fibre attached to NBR			
Cylinder Head Stud	6.55	A2-70 ²⁾ ³⁾			
Gasket	6.56	Aramide fibre attached to NBR ²⁾ ³⁾			

Seal Tank	1.12	1.0308		1.4571	
-----------	------	--------	--	--------	--

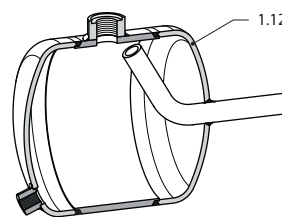

- ¹⁾ Lower Spring Plate not used by DN 65 and DN 100
- ²⁾ only used by Actuator Size B1, B2
- ³⁾ only used by Actuator Size A1, A2, A3

K Trim
 S Screwed Seat
 D Gasket Set
 M Diaphragm

Dimensions and Weights

Pressure Reducing Valve

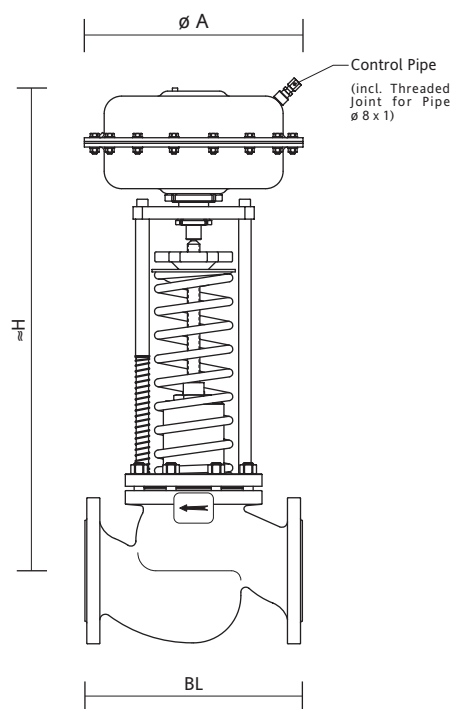

Designations	ø A	Nominal Size DN												
		15	20	25	32	40	50	65	80	100	125	150	200	
BL Face to Face Dimensions in mm acc. to EN 558-1 basic line 1		130	150	160	180	200	230	290	310	350	400	480	600	
≈ Height in mm	H with Actuator B11	150	490	490	490	510	525	600	605					
	H with Actuator B2	160								700				
	H with Actuator A11	150	490	490	490	510	525	600	605	690		805	825	860
	H with Actuator A2	160								690	690	805	825	860
	H with Actuator A3	195						600	605	690	690	805	825	860
	H with Actuator A4	270	510	510	510	530	545	620	625	710	710	825	845	880
	H with Actuator A51	355								775	775	890	910	945
H with Actuator A6	510										925	945	980	
≈ Weight in kg	Weight with Actuator B11		10	11	12	15	17	22	30					
	Weight with Actuator B2									60				
	Weight with Actuator A11		10	11	12	15	17	22	30	43		85	118	179
	Weight with Actuator A2									45	59	87	120	181
	Weight with Actuator A3							25	33	46	60	88	121	182
	Weight with Actuator A4		12	13	14	17	19	24	32	45	59	87	120	181
	Weight with Actuator A51									58	72	100	133	194
Weight with Actuator A6											110	143	204	
Flanges Drilled and Dimensioned acc. to		DIN 2526, Form C												

Seal Tank

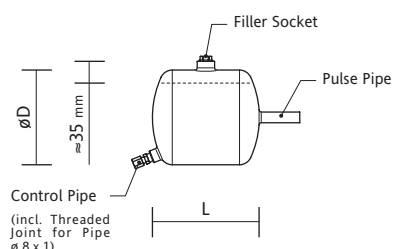

Designation	Seal Tank Dimensions		
	G1 suitable for DN 15 - 65	G2 suitable for DN 80 - 100	G3 suitable for DN 125 - 200
L Length in mm	206	172	250
øD	88,9	152,4	152,4
Pulse Pipe	ø 17,2 x 2,6		
≈ Weight in kg	1,7	3,5	4,9

SPM - Code

Type	DN	PN	Body/Cert.	Plug	Seat	kvs	Trim	Actuator	S
5801 DC	50	40	1.0619/00	T	32	25	1.4571	A3 G1	S

Body Form
Three-Flange D

Form of Connection
Flange acc. to DIN 2526 Form C C

Nominal Size 15 - 200

Nominal Pressure PN 10 10
Nominal Pressure PN 16 16
Nominal Pressure PN 25 25
Nominal Pressure PN 40 40

Body Material 0.7043
1.0619
1.4581

Certificates for pressure stressed parts
without O .
EN 10 204 2.2 Z .
3.1B (Survey of Cert.) B .
3.1B (CMTR) D .
Pressure/Tightness Certificate
without . O
EN 10 204 2.2 . Z
3.1B . B
3.1A . A

Plug
Disk Plug T

Port Size 12 - 120

kvs - Value 1,8 - 255

Plug, Seat Material 1.4571

Seal Tank
G1
G2
G3

Actuator Size
A11
A2
A3
A4
A51
A6
B11
B2

Application

Self-actuating Pressure Relief Valves are used to provide a constant pressure **upstream** of its built-in position. Suitable for steam, non inflammable vapours and gases and neutral liquids.

Product features

Body shape gives optimum flow characteristic

- Excellent flow dynamics when correctly selected
- Heavy top guided plug
- Largest possible kvs-values
- High degree of accuracy in the inlet pressure by carefully selected springs

Long service life and operational reliability

- Maintenance free
- Strong guide, giving minimum vibration and wear
- The valve stem is sealed by a CrNi-steel bellows which is also used to pressure balance the valve

Replaceable trim

- Simple maintenance as the valve body remains in the piping when trim is replaced
- Screwed seat

Wide range of application

- Up to 5 adjustment ranges are available per size
- Easy control point setting by the handwheel at any time

Quick delivery

- **SELF**ACT Valves can be delivered within one week

Quality assurance system certified acc. EN ISO 9001 : 2000 including product development.

Schmidt minimal Valve Standards acc. to the Pressure Equipment Directive 97/23/EG Modul H

Pressure Relief Valve

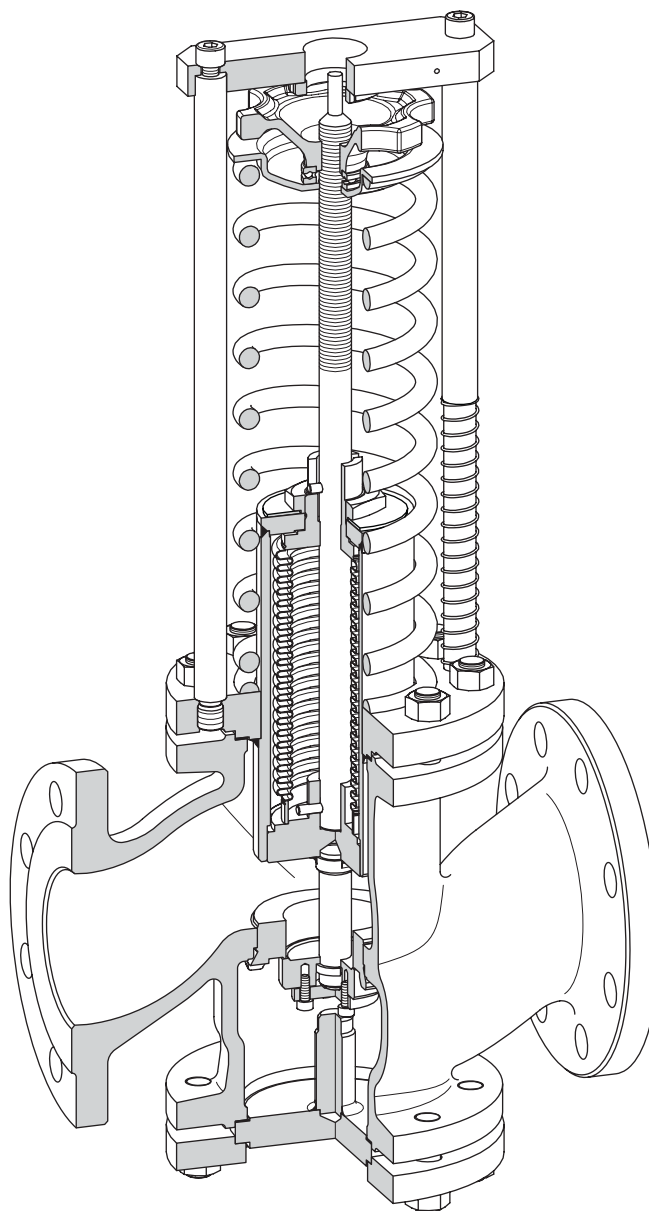
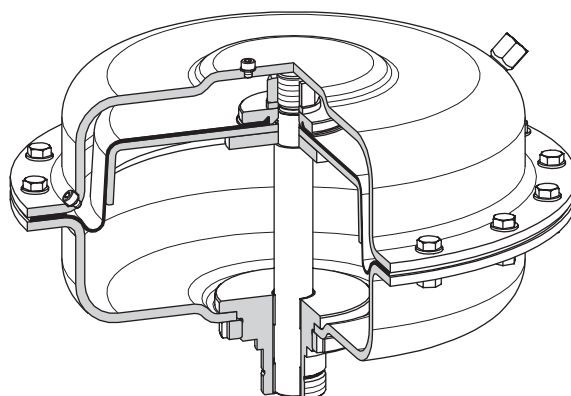

The Pressure Relief Valve consists in the main of: Body with the Trim, Bellows and Actuator and > 100 °C a water Seal Tank.

Body with Flange Connection

Type	Material	Atteste		Nominal Size DN								
		without	with	15	20	25	32	40	50	65	80	100
Pressure Relief Valve	0.7043	Material resp. Pressure/Leakage Certificate, Schmidt minimal Valve Standard acc. to PED 97/23EC Kat. II	Pressure resp. Leakage Certificate acc. to EN 10 204 - 2.2, 3.1B						•	•	•	•
	1.0619			•	•	•	•	•	•	•	•	•

Form of Connection, Nominal Pressure Range

Form of Connection			Material	PN	Nominal Size DN							
					15	20	25	32	40	50	65	80
Flanges acc. to DIN 2526	Form C	•	0.7043	10								
				16					•	•	•	•
				25						•	•	•
Form C	•		1.0619	10								
				16	•	•	•	•	•	•		
				25	•	•	•	•	•	•	•	•
				40							•	•

Pressure-Temperature Ratings (acc. to DIN 2401)

PN	Body Material	Service Temperature in °C	-85	-60	-10	0	120	200	250	300	350	400	450	500	530
10	0.7043	Working Pressure in bar			10	10	10	8	8	7	6				
	1.0619				10	10	10	8	7	5	4	3			
16	0.7043	Working Pressure in bar			16	16	15	13	12	11	10				
	1.0619				16	16	16	14	13	11	10	8			
25	0.7043	Working Pressure in bar			25	25	24	20	19	17	16				
	1.0619				25	25	25	22	20	17	16	13			
40	1.0619	Working Pressure in bar			40	40	40	35	32	28	24	21			

Disc Plug

Characteristic: linear

Kvs (m³/h)	Port Size (mm)	Stroke (mm)	Material/Design 1.4571 standard	Incorporable seat diameter depends on nominal size DN										
				15	20	25	32	40	50	65	80	100		
3,0	20	5	•	•										
5,0	20	5	•		•									
8,0	20	5	•			•								
10	20	6	•				•							
15	25	6	•					•						
25	32	8	•						•					
38	40	9	•							•				
59	50	11	•								•			
87	65	12	•									•		

Rangeability

Standard Rangeability:	Rangeability 1 : 10
------------------------	---------------------

Leakage-class acc. to DIN 3230 Teil 3

Plug	Plug Design	Leakage-class acc. DIN 3230 - BO	Test Medium	Test Pressure (bar)	max. Seat Leakage in % of kvs
standard	metal-to-metal seated, reseated	Class 1 - tight	Air	Working Pressure, max. 6	0,0 - tight

Actuator Selection

Incorporable Actuator Size depends on Adjustment Range and Nominal Size:

Adjustment Range (bar g)	Nominal Size DN									
	15	20	25	32	40	50	65	80	100	
8 - 20	B11									
8 - 16,5								A11	B2	
3,2 - 10								A2		
2,4 - 10						A11				
1,1 - 10	A11									
1,2 - 4,0								A3		
0,8 - 3,0						A3				
0,4 - 1,5								A4		
0,1 - 1,4	A4									
0,1 - 1,0						A4				
0,1 - 0,6								A51		

Deviation

The characteristics of the Pressure Relief Valve is like a proportional controller. Their construction therefore has a max. permanent deviation dependent on the nominal size and actuator size.

Actuator Size	max. Deviation in ± bar for Actuator / Nominal Size DN ¹⁾								
	15	20	25	32	40	50	65	80	100
B11	0,23	0,37	0,56	0,64	0,90	1,00	1,92		
B2									1,99
A11	0,11	0,19	0,29	0,32	0,43	0,43	0,68	1,21	
A2								0,59	1,02
A3						0,16	0,23	0,32	0,48
A4	0,02	0,02	0,04	0,04	0,06	0,06	0,08	0,11	0,14
A51								0,05	0,07

Operating Medium Temperature > 100 °C

If the medium temperature is > 100 °C the use of a Seal Tank is essential otherwise the diaphragm of the actuator will be destroyed !

Seal Tank	Nominal Size DN								
	15	20	25	32	40	50	65	80	100
1	G1								
2								G2	

¹⁾ The actual deviation depends on utilisation of the flow range:
 Example DN 50 and actuator B11 -> max. deviation = ± 1,00 bar
 kvs-value max. 25 m³/h, actually used kvs-value 18,5 m³/h -> utilisation = 74 % } the actually deviation = 1,00 x 0,74 = ± 0,74 bar

Installation recommendation

The successful employment of the Pressure Relief Valve depends directly on a suitable design of the mounting arrangement. As the function of the Pressure Relief Valve depends greatly on the consideration of the physical possibilities, it is recommended to observe the stated standard values. Deviations may lead to considerable fluctuations in the control loop for which the Pressure Relief Valve manufacturer rejects any liability whatsoever. In borderline cases, an expensive conversion of the piping should be expected. Even though the physical processes may in individual cases justify a deviation from the standard values, however, this requires a comprehensive system knowledge and the express approval of the manufacturer.

Physical requirements

- Pressure Relief Valves are used primarily for **steam, non inflammable vapours and gases**. It also has a limited use for **neutral liquids**, because the close direction of the plug is in the flow direction of the medium and that can produce vibrations (hammer) at a utilisation for less than 20 %.
- Realistic **rangeability 1 : 10 !**
- At service conditions of **more than 100 °C** it is necessary to protect the diaphragm against overheating by using a **seal tank !**
- Ensure that the outlet velocity for **vapours and gases** is less than **70 m/s** and **liquids and wet steam** is less than **8 m/s**, otherwise the standards for friction loss, wearing, pressure shock and noise of flow will be increase distinctly.
- The safe load **relative differential pressure** depends on nominal size and is for
 - DN 15 - 50 max. **24 bar**
 - DN 65 - 100 max. **20 bar**
 - DN 150 - 200 max. **15 bar**,
 otherwise the trim can be overload.

System requirements

- System drawings with design recommendation. Experience shows that deviations result in considerable problems.

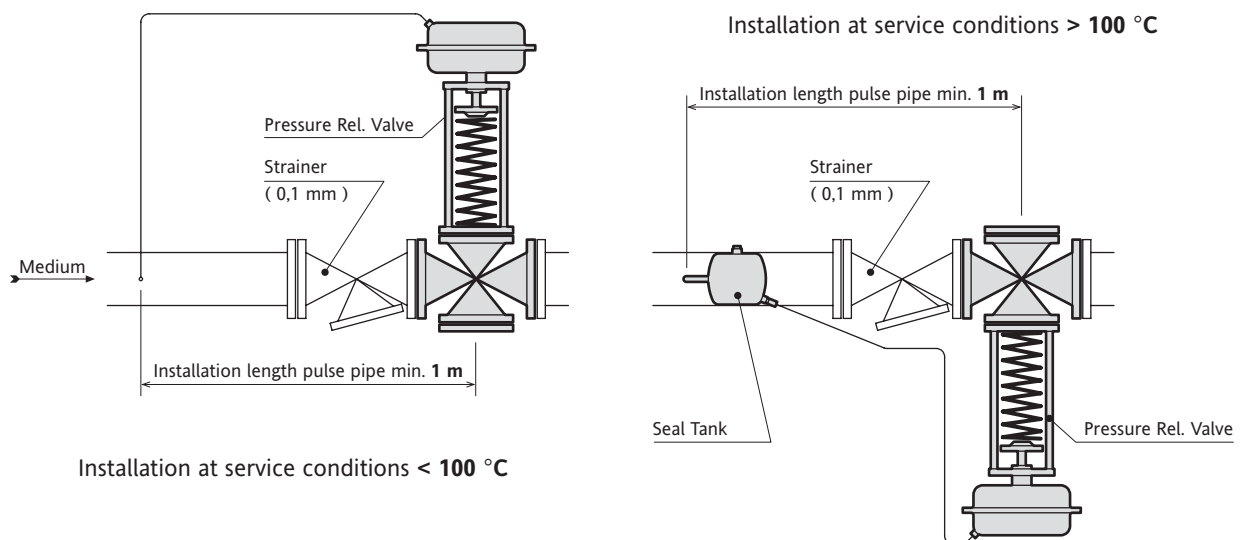

For installing a water seal tank be carefully to place it higher up than the valve actuator !

Installation

- At service conditions **more than 100 °C** pour water into the filler socket of the seal tank until it emerges from the vent without bubbles. Now close the vent screw and continue filling until the water reaches a height of 35 mm below the top level of the filler socket. After closing the filler socket, the pressure reducing valve is ready to work.
- At service conditions **less than 100 °C** and gaseous the pressure reducing valve is ready to work. In case of liquid, the actuator must be filled completely with liquid by using its upper vent screw.

Parts List

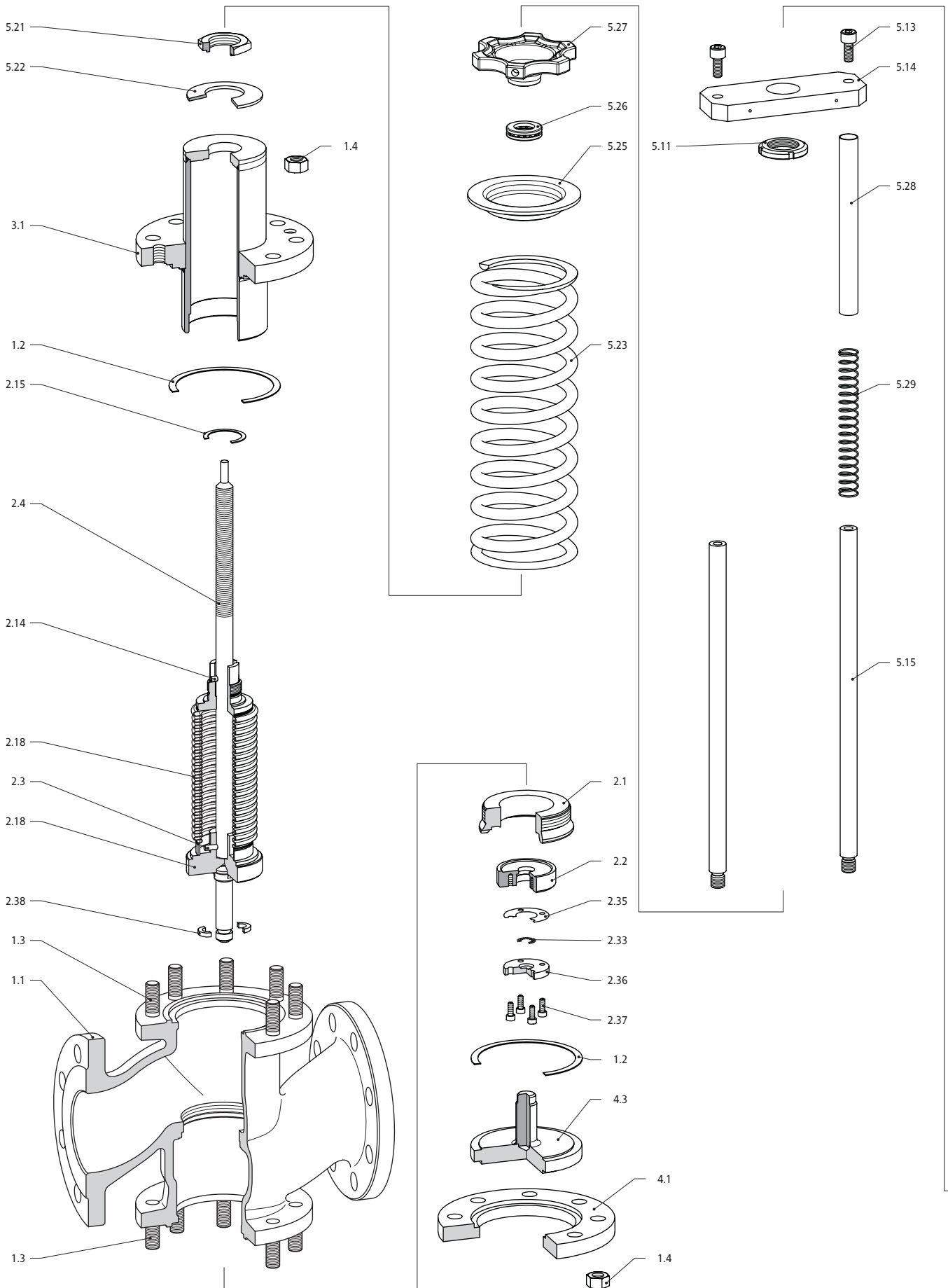

SelfAct™ - Selfacting Control Valve

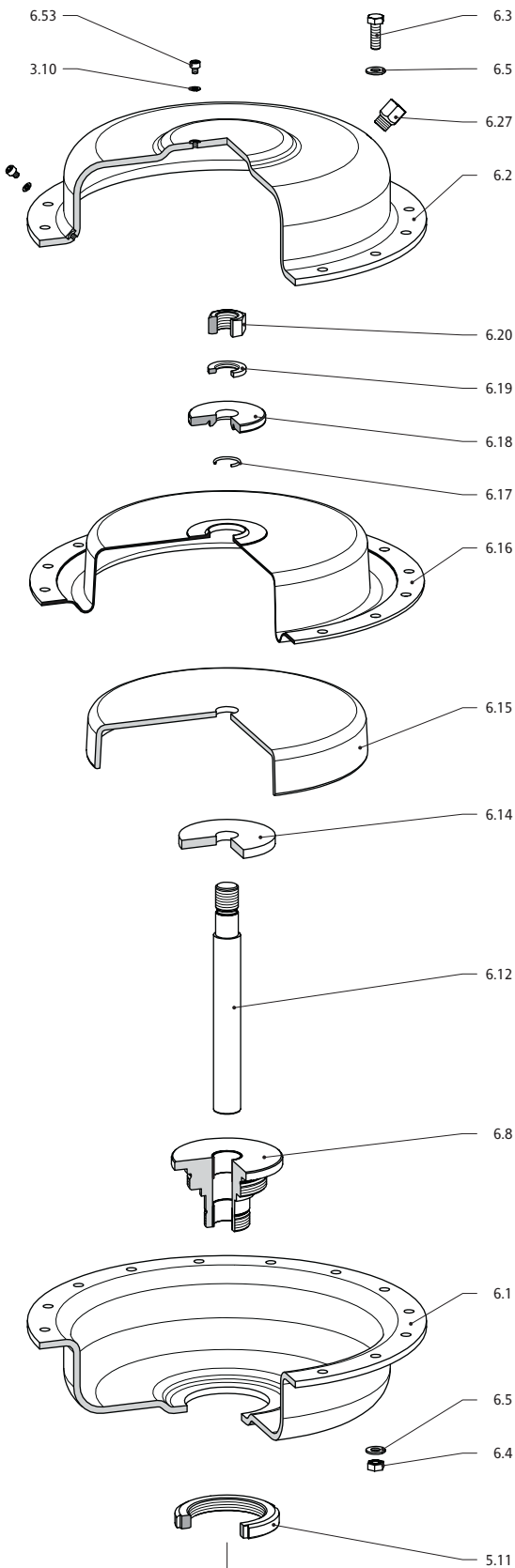

Designation	Part	Material		Spare Parts
		0.7043	1.0619	
Body	1.1	0.7043	1.0619	
Bonnet Gasket	1.2	Pure Graphite on Support Plate from 1.4571		D
Stud Bolt	1.3	YK		
Hex Nut	1.4	YK		
Screwed Seat	2.1	1.4571		S
Disk Plug	2.2	1.4571		K
Straight Pin	2.3	1.4021		B
Stem	2.4	1.4021		
Spring Pin	2.14	1.1231		
Gasket	2.15	Pure Graphite on Support Plate from 1.4571		D
Bellows Unit	2.18	1.4571		B
Lock Washer	2.33	1.8159		K
Gasket	2.35	Pure Graphite on Support Plate from 1.4571		
Cover	2.36	1.4021		
Cylinder Head Stud	2.37	A2-70		
Segment	2.38	1.4021		
Bonnet	3.1	1.0460		
Union Flange	4.1	1.0460		
Insert	4.3	1.0460		
Lock Nut, Actuator	5.11	Seel, chromatinized		
Cylinder Head Stud	5.13	8.8, chromatinized		
Plate	5.14	1.1191, chromatinized		
Column	5.15	1.0736, chromatinized		
Hex Nut	5.21	1.0501		
Belleville Spring	5.22	1.8159		
Compression Spring	5.23	1.7103, chromatinized		
Lower Spring Plate	5.24	Sheet Steel, painted ¹⁾		
Upper Spring Plate	5.25	Sheet Steel, painted		
Ball Bearing	5.26	Chrome Steel		
Hand Wheel	5.27	0.6025, painted		
Setting Scale	5.28	1.0308		
Spring	5.29	1.1191, chromatinized		

Lock Nut, Actuator	5.11	Steel, chromatinized		
Lower Casing	6.1	1.0332, powder coated		
Upper Casing	6.2	1.0332, powder coated		
Hex Screw	6.3	A2-70		
Hex Nut	6.4	A2-70		
Washer	6.5	A2		
Distance Ring	6.7	1.0460, chromatinized ²⁾		
Guide Bush	6.8	1.0460, chromatinized / Bronze, Steel		
Actuator Stem	6.12	1.4122		
Washer	6.14	1.0736, chromatinized		
Diaphragm Plate	6.15	1.0332, chromatinized		
Diaphragm	6.16	NBR		M
O-Ring	6.17	NBR		
Pressure washer	6.18	1.4305		
Lock Washer	6.19	A2		
Hex Nut	6.20	A2-70		
Diaphragm Plate Ring	6.52	1.0460 ²⁾		
Lock Screw	6.53	A2-70		
Gasket	6.54	Aramide fibre attached to NBR		
Cylinder Head Stud	6.55	A2-70 ²⁾ ³⁾		
Gasket	6.56	Aramide fibre attached to NBR ²⁾ ³⁾		

Seal Tank	1.12	1.0308		
-----------	------	--------	--	--

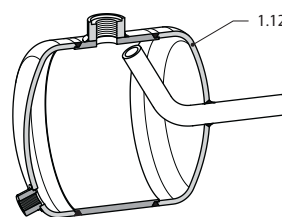

- ¹⁾ Lower Spring Plate not used by DN 65 and DN 100
- ²⁾ only used by Actuator Size B1, B2
- ³⁾ only used by Actuator Size A1, A2, A3

B Bellows Unit
 K Plug Unit
 S Screwed Seat
 D Gasket Set

M Diaphragm

Dimensions and Weights

Pressure Relief Valve

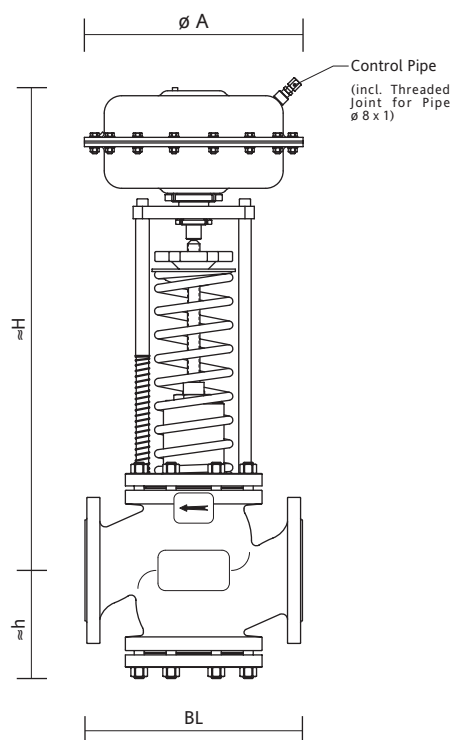

Designation	ø A	Nominal Size DN									
		15	20	25	32	40	50	65	80	100	
BL Face to Face Dimensions in mm acc. to EN 558-1 basic line 1		130	150	160	180	200	230	290	310	350	
≈ h		70	70	70	95	110	120	150	160	180	
≈ Height in mm	H with Actuator B11	150	505	505	505	510	525	595	600		
	H with Actuator B2	160								700	
	H with Actuator A11	150	505	505	505	510	525	595	600	690	
	H with Actuator A2	160								690	690
	H with Actuator A3	195						595	600	690	690
	H with Actuator A4	270	525	525	525	530	545	615	620	710	710
	H with Actuator A51	355								775	775
≈ Weight in kg	Weight with Actuator B11		13	14	15	17	21	26	38		
	Weight with Actuator B2									76	
	Weight with Actuator A11		13	14	15	17	21	26	38	51	
	Weight with Actuator A2									53	75
	Weight with Actuator A3							29	41	54	76
	Weight with Actuator A4		15	16	17	19	23	28	40	53	75
	Weight with Actuator A51									66	88
Flanges Drilled and Dimensioned acc. to		DIN 2526, Form C									

Seal Tank

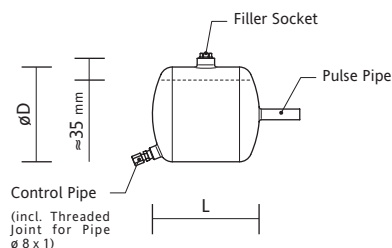

Designation	Seal Tank Dimensions	
	G1 suitable for DN 15 - 65	G2 suitable for DN 80 - 100
L Length in mm	206	172
øD	88,9	152,4
Pulse Pipe	ø 17,2 x 2,6	
≈ Weight in kg	1,7	3,5

SPM - Code

Type	DN	PN	Body/Cert.	Plug	Seat	kvs	Trim	Actuator	S
5610 VC	50	40	1.0619/00	T	32	25	1.4571	A3 G1	S

Body Form
Four-Flange V

Form of Connection
Flange acc. to DIN 2526 Form C C

Nominal Size 15 - 100

Nominal Pressure PN 10 10
Nominal Pressure PN 16 16
Nominal Pressure PN 25 25
Nominal Pressure PN 40 40

Body Material 0.7043
1.0619

Certificates for pressure stressed parts
without O .
EN 10 204 2.2 Z .
3.1B (Survey of Cert.) B .
3.1B (CMTR) D .
Pressure/Tightness Certificate
without . O
EN 10 204 2.2 . Z
3.1B . B
3.1A . A

Plug
Disk Plug T

Port Size 20 - 65

kvs - Value 3,0 - 87

Plug, Seat Material 1.4571

Seal Tank
G1
G2

Actuator Size
A11
A2
A3
A4
A51
B11
B2

Diagram to select the Kvs - value for water

• Example - **water:**

Differential Pressure Δp 2,4 bar
 Volume Flow Rate Q 3,8 m³/h

The operational data are registered in the diagram below for the example. The intersecting point shows the kvs-value as a result from differential pressure and volume flow rate. In case of an intersecting point between two kvs-lines the bigger one has to be chosen.

• Solution > Kvs-value 3,0 m³/h

Diagram to select the Kvs - value for water

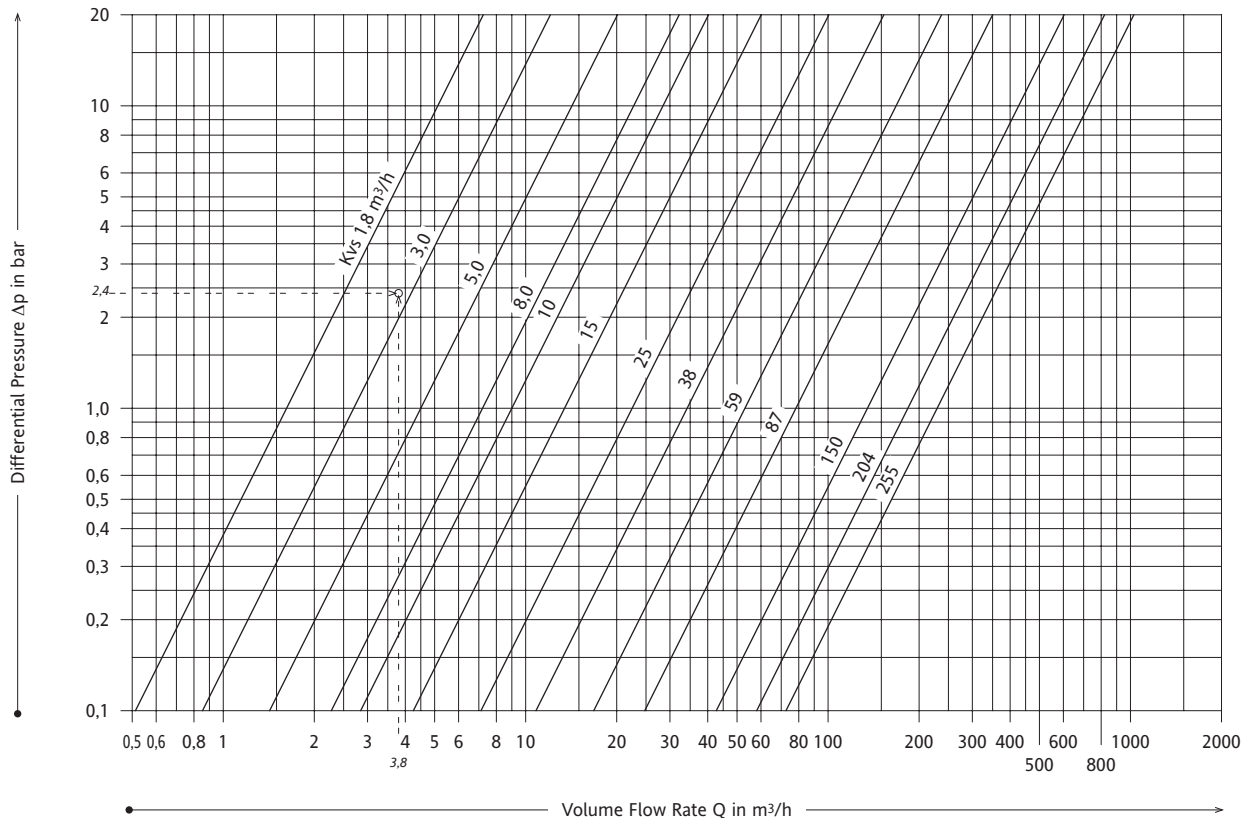

Tolerance of Kvs-values (± 10 % acc. to VDI / VDE 2173) is considered in the diagram !

Diagram to select the Kvs - value for steam

• Example - **saturated steam:**

Upstream Pressure p_1 11,5 bar (g)
 Differential Pressure Δp 2 bar
 Mass Flow Rate W 1 200 kg/h

The operational data are registered in the diagram beside for the example. The intersecting point shows the kvs-value as a result from upstream pressure, differential pressure and mass flow rate. In case of an intersecting point between two kvs-lines the bigger one has to be chosen.

• Solution > Kvs-value 15 m³/h

• Example - **superheated steam:**

Upstream Pressure p_1 11,5 bar (g)
 Differential Pressure Δp 2 bar
 Upstr. Temperature t_1 350 °C
 Mass Flow Rate W 1 200 kg/h

The operational data are registered in the diagram beside for the example. The intersecting point shows the kvs-value as a result from upstream pressure, upstream temperature and mass flow rate combined with upstream pressure and differential pressure. In case of an intersecting point between two kvs-lines the bigger one has to be chosen.

• Solution > Kvs-value 25 m³/h

CAUTION: The physical conditions (liquid, saturated steam, superheated steam) are a result from the service condition and is shown in the literature on the subject (steam table) !

Diagram to select the Kvs - value for steam

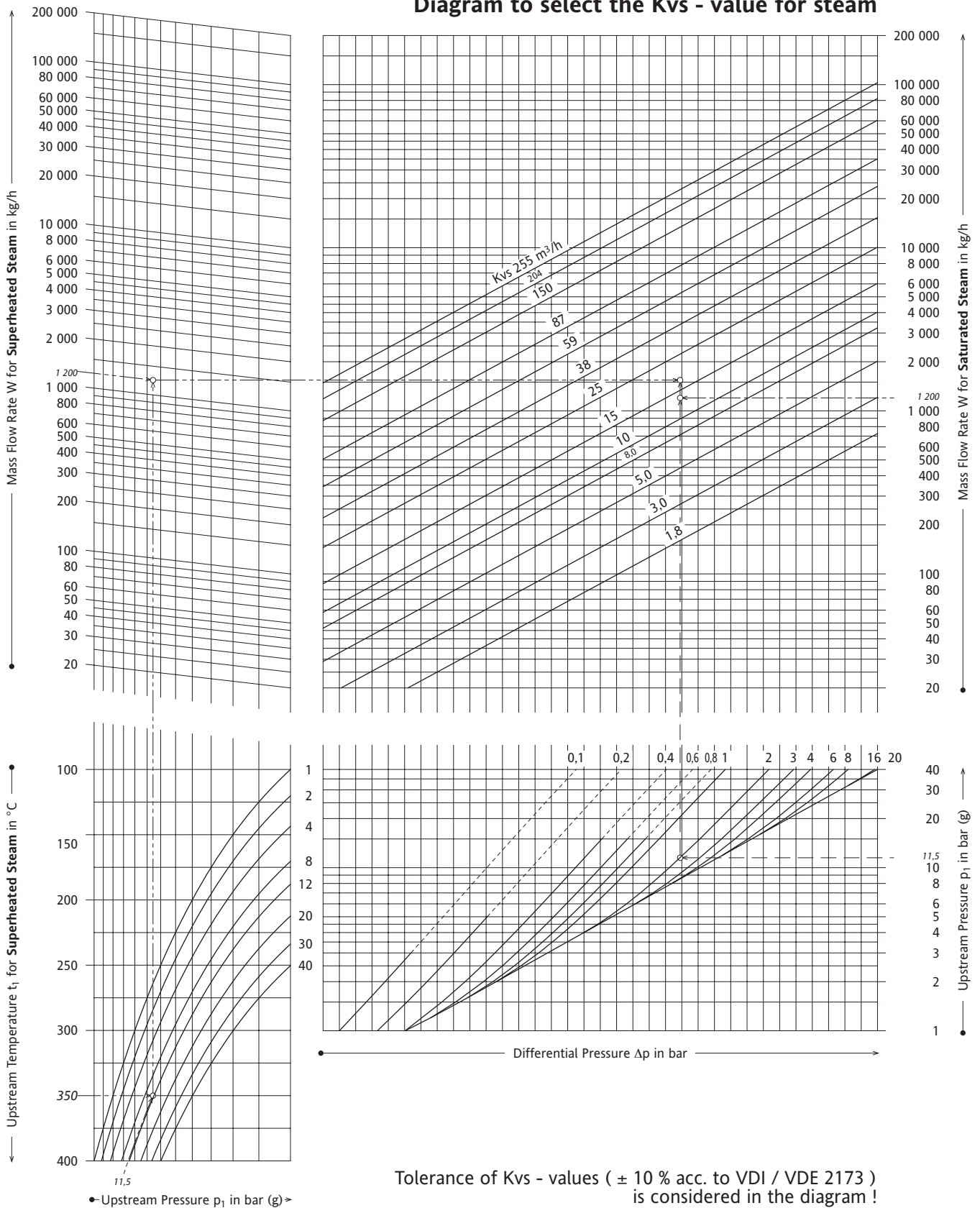

Tolerance of Kvs - values (± 10 % acc. to VDI / VDE 2173) is considered in the diagram !



Flowserve (Austria) GmbH
Control Valves - Villach Operation

Kasernengasse 6
9500 Villach
Austria

Tel.: +43 (0) 4242 41181-0
Fax.: +43 (0) 4242 41181-50

villach_operation@flowserve.com

www.flowserve.com
www.flowserve-villach.com

SAENBR5801-00 05.07

Your contact:

[Empty dashed box for contact information]



™ indicates a trade mark of Flowserve.

Information given in this product specification sheet is made in good faith and based upon specific testing but does not, however, constitute a guarantee.

Modifications without notice in line with technical progress.

PSS 108301 05/07 SelfAct en