

PRESSURE REDUCING VALVE RP45 (EN)

DESCRIPTION

The ADCA RP45 series pressure reducing valves are single seated, bellows sealed controllers that operate without auxiliary energy. Designed for use with steam, compressed air, and other gases compatible with the construction. These valves are particularly suitable for reducing steam pressure in all energy and process systems where pressures must be kept under control.

MAIN FEATURES

Specially designed high durability bellows, providing pressure balancing and frictionless plug stem.
Robust construction (fit-and-forget).
Suitable for use with high pressure turndowns.
Interchangeable actuators and adjustment springs.

OPTIONS: Soft sealing in PTFE/GR for use with steam.
Soft sealing in nitrile rubber for use with air and gases.
Low-noise flow divider.
Sensing pipe on body.

USE: Steam, compressed air and other gases compatible with the construction. Limited use with liquids. Consult manufacturer before installing the valve with liquids.

AVAILABLE MODELS: RP45G and RP45GT or N – SG iron.
RP45S and RP45ST or N – carbon steel.
RP45i and RP45iT or N – stainless steel (only available from DN 15 to DN 100).
Suffix T: soft sealed with PTFE/GR.
Suffix N: soft sealed with nitrile rubber.

SIZES: DN 15 to DN 150.

CONNECTIONS: RP45G – Flanged EN 1092-2 PN 16.
RP45S and RP45i – Flanged EN 1092-1 PN 16 or PN 40.
Standard PN 16 DN 65 flanges are supplied with 4 holes. 8 holes, according to EN 1092-1/-2 on request.

AVAILABLE ACTUATORS: A1, A10, A11, A12, A3, A4, B1, B3, B4 and C11 – carbon steel.
A2, A21, B2 and B21 – SG iron or carbon steel.
A1i, A10i, A11i, A12i, A2i, A21i, A3i and A4i – stainless steel.

INSTALLATION: See IMI – Installation and maintenance instructions.



**RP45
DN 15 to DN 100**

**RP45i
DN 15 to DN 100**



**RP45
DN 125 and DN 150**

**RP45
DN 15 to DN 100
with sensing
pipe on body**

CE MARKING – GROUP 2 (PED – European Directive)		
PN 16	PN 40	Category
DN 15 to 50	DN 15 to 32	SEP
DN 65 to 150	DN 40 to 100	1 (CE marked)
–	DN 125 and 150	2 (CE marked)

LIMITING CONDITIONS

Valve model	RP45G RP45S RP45i	RP45S RP45i	RP45GT RP45ST RP45iT	RP45ST RP45iT	RP45GN RP45SN RP45iN	RP45SN RP45iN
Body design conditions	PN 16	PN 40	PN 16	PN 40	PN 16	PN 40
Maximum upstream pressure	13 bar	25 bar	13 bar	25 bar	13 bar	25 bar
Maximum downstream pressure (DN 15 to 100)	13 bar	18 bar	13 bar	18 bar	13 bar	18 bar
Maximum downstream pressure (DN 125 and 150)*	12 bar	16,5 bar	12 bar	16,5 bar	12 bar	16,5 bar
Minimum downstream pressure	0,15 bar	0,15 bar	0,15 bar	0,15 bar	0,15 bar	0,15 bar
Maximum operating temperature	200 °C	250 °C	200 °C	200 °C	80 °C	80 °C
Maximum reducing ratio	25:1	25:1	25:1	25:1	10:1	10:1
Rangeability	10:1	10:1	10:1	10:1	10:1	10:1
Maximum hydraulic factory valve body test	24 bar	60 bar	24 bar	60 bar	24 bar	60 bar

* Stainless steel models are not available in these sizes.

Remark: Other soft materials and temperature limits on request.

Actuator model	A1 A1i	A10 A10i	A11 A11i	A12 A12i	A2 A2i	A21 A21i	A3 A3i	A4 A4i	B1	B2	B21	B3	B4	C11
Maximum operating pressure (bar)	25	25	25	25	12	18	2,5	1,5	25	13	18	2,5	1,5	25
Maximum operating temperature	90 °C *													

* The water seal pot must be installed in the sensing pipe when operating with steam or liquids at higher temperatures.

FLOW RATE COEFFICIENTS (m³/h)

SIZE	DN 15	DN 20	DN 25	DN 32	DN 40	DN 50	DN 65	DN 80	DN 100	DN 125	DN 150
Kvs	4,8	6,9	9,1	11,8	14,4	26,5	51,5	79,5	129,5	150	204

SATURATED STEAM CAPACITY TABLE (kg/h)

INLET (barg)	SIZE										
	DN 15	DN 20	DN 25	DN 32	DN 40	DN 50	DN 65	DN 80	DN 100	DN 125	DN 150
0,5	51	68	90	118	186	300	460	800	1250	1500	1800
0,75	63	84	112	146	230	360	580	1000	1550	1750	2350
1	75	100	133	175	280	430	700	1200	1850	2250	3200
1,5	100	133	175	240	360	590	910	1600	2500	3000	4000
2	126	170	230	290	450	730	1160	2000	3050	3500	4700
2,5	150	200	260	350	550	880	1390	2400	3600	4500	6500
3	175	240	310	400	640	1010	1600	2700	4300	5500	8500
4	220	290	390	510	800	1300	2000	3400	5400	7000	10000
5	260	350	480	620	1000	1600	2500	4200	6500	8000	12000
6	330	440	580	760	1220	1930	3000	5100	8000	9500	14000
7	400	520	700	910	1430	2300	3600	6100	9500	11500	16000
8	450	600	800	1040	1670	2700	4100	7100	11000	13000	18000
9	500	670	880	1180	1800	2900	4600	7800	12000	15000	20000
10	560	750	980	1300	2000	3200	5100	8500	13500	17000	22000
12	680	900	1180	1540	2500	4000	6100	10500	16300	20000	25000
14	800	1050	1400	1850	2900	4700	7200	12600	19000	23000	29000
16	920	1230	1630	2150	3400	5500	8300	14600	22000	26000	33000
18	1040	1400	1860	2450	3800	6200	9500	16600	25000	30000	38000
20	1170	1540	2100	2700	4200	7000	10800	18600	28000	33000	42000
22	1330	1780	2350	3050	4900	7800	12200	21000	32000	36000	45000
24	1500	2000	2600	3400	5400	8700	13700	23500	36000	40000	48000
25	1600	2150	2800	3600	5700	9200	14500	25500	38000	42000	50000

Remark: For pressure ratios where $P2 > 0,7 P1$ and/or when the operating medium is superheated steam, a correction factor must be applied. See next page.



CORRECTION FACTORS

Pressure ratio:

The capacities given in the "Saturated steam capacity table" are applicable in scenarios where $P2 < 0,7 P1$. In the remaining scenarios a correction factor must be applied:

PRESSURE RATIO * P2 / P1	CORRECTION FACTOR f
≥ 0,7	1,25
≥ 0,8	1,6
≥ 0,9	2,25

* Pressure ratio in bar abs (barg + 1)

Superheated steam:

When the medium is superheated steam, instead of saturated steam, a correction factor must also be applied. The required mass flow must be multiplied by the following factor:

$\frac{V_h}{V_s}$, where V_h = specific volume of superheated steam, and
 V_s = specific volume of saturated steam.

ACTUATOR AND SPRING SELECTION TABLE																	
SIZE		ACTUATOR															
		A4 A4i		A3 A3i	A2 A2i	A21 A21i	A1 A1i	A10 A10i	A11 A11i	A12 A12i	B4	B3	B2	B21	B1	C11	
DN 15	Regulating range (bar)	0,15 to 0,49	0,5 to 0,99	1 to 1,6	1,7 to 3,8	3,9 to 5,5	5,6 to 8,2	-	-	8,3 to 13	10 to 18	-	-	-	-	-	
	Spring N°	66	60	60	60	60	60	-	-	60	60.1	-	-	-	-	-	
DN 20	Regulating range (bar)	0,15 to 0,49	0,5 to 0,99	1 to 1,6	1,7 to 3,8	3,9 to 5,5	5,6 to 8,2	-	-	8,3 to 13	10 to 18	-	-	-	-	-	
	Spring N°	66	60	60	60	60	60	-	-	60	60.1	-	-	-	-	-	
DN 25	Regulating range (bar)	0,15 to 0,49	0,5 to 0,99	1 to 1,6	1,7 to 3,8	3,9 to 5,5	5,6 to 8,2	-	-	8,3 to 13	10 to 18	-	-	-	-	-	
	Spring N°	66	60	60	60	60	60	-	-	60	60.1	-	-	-	-	-	
DN 32	Regulating range (bar)	0,15 to 0,49	0,5 to 0,99	1 to 1,6	1,7 to 3,8	3,9 to 5,5	5,6 to 8,2	-	-	8,3 to 13	10 to 18	-	-	-	-	-	
	Spring N°	66	60	60	60	60	60	-	-	60	60.1	-	-	-	-	-	
DN 40	Regulating range (bar)	0,15 to 0,49	0,5 to 0,99	1 to 1,6	1,7 to 3,8	3,9 to 5,5	5,6 to 8,2	-	-	8,3 to 13	10 to 18	-	-	-	-	-	
	Spring N°	66	60	60	60	60	60	-	-	60	60.1	-	-	-	-	-	
DN 50	Regulating range (bar)	0,15 to 0,49	0,5 to 0,99	1 to 1,9	2 to 4,2	4,3 to 6,9	7 to 8,5	-	10 to 18	8,6 to 13	-	-	-	-	-	-	
	Spring N°	67	61	61	61	61	64	-	61	64	-	-	-	-	-	-	
DN 65	Regulating range (bar)	0,15 to 0,49	0,5 to 0,99	1 to 1,9	2 to 4,2	4,3 to 6,9	7 to 8,5	-	10 to 18	8,6 to 13	-	-	-	-	-	-	
	Spring N°	67	61	61	61	61	64	-	61	64	-	-	-	-	-	-	
DN 80	Regulating range (bar)	0,15 to 0,45	0,46 to 0,99	1 to 1,9	2 to 5	5,1 to 8,9	9 to 13	11 to 18	-	-	-	-	-	-	-	-	
	Spring N°	68	62	62	62	62	65	62	-	-	-	-	-	-	-	-	
DN 100	Regulating range (bar)	0,15 to 0,45	0,46 to 0,99	1 to 1,9	2 to 6	6,1 to 13	-	11 to 18	-	-	-	-	-	-	-	-	
	Spring N°	69	63	63	63	63	-	63	-	-	-	-	-	-	-	-	
DN 125	Regulating range (bar)	-	-	-	-	-	-	-	-	-	-	0,5 to 1,5	1,1 to 2,5	1,5 to 5,5	4 to 8,5	6 to 12	8 to 16,5
	Spring N°	-	-	-	-	-	-	-	-	-	-	70	70	70	70	70	70
DN 150	Regulating range (bar)	-	-	-	-	-	-	-	-	-	-	0,5 to 1,5	1,1 to 2,5	1,5 to 5,5	4 to 8,5	6 to 12	8 to 16,5
	Spring N°	-	-	-	-	-	-	-	-	-	-	70	70	70	70	70	70



HOW TO SIZE (USING STEAM TABLE)

Example

Required saturated steam capacity: 300 kg/h; Upstream pressure: 3 bar; Required downstream pressure: 2 bar.

Solution:

First determine correction factor for pressure ratio: $(2+1) / (3+1) = 0,75 \rightarrow f = 1,25$

Then multiply the given capacity: $300 \times 1,25 = 375 \text{ kg/h}$

Afterwards, refer to the cell with the number "3" in the column "INLET" of the saturated steam capacity table. In that line, the values for selection of the pressure reducing valve size can be found. In this particular scenario, a value equal to or higher than 375 kg/h is required, and the right selection would be DN 32, with a capacity of 400 kg/h.

On the actuator and spring selection table, for a downstream pressure of 2 bar, the recommended actuator is the A2, and the regulating spring is N° 60.

Remarks: Never size the valve according to the pipe diameter in which it has to be fitted, but according to the actual flow required. Pipe sizing must also respect the maximum recommended flow velocities, according to the medium.

HOW TO SIZE (USING Kvs)

Please consult formulas on IS PV10.00 E or consult manufacturer.

HOW TO ORDER

RP45G DN 32 PN 16 valve complete with spring N° 60, A2 actuator, condensate vessel and copper sensing pipe.

INSTALLATION

Horizontal installation with the actuator vertically, pointing downwards.

Installation with the actuator pointing upwards is possible only when the medium temperature is below 90 °C.

The sensing pipe, if not fitted on the valve body, must be installed downstream of the valve at a minimum of 1 meter away or 15 pipe diameters.

In steam applications, a "Y" strainer, humidity separator and steam trap should be installed upstream of the valve.

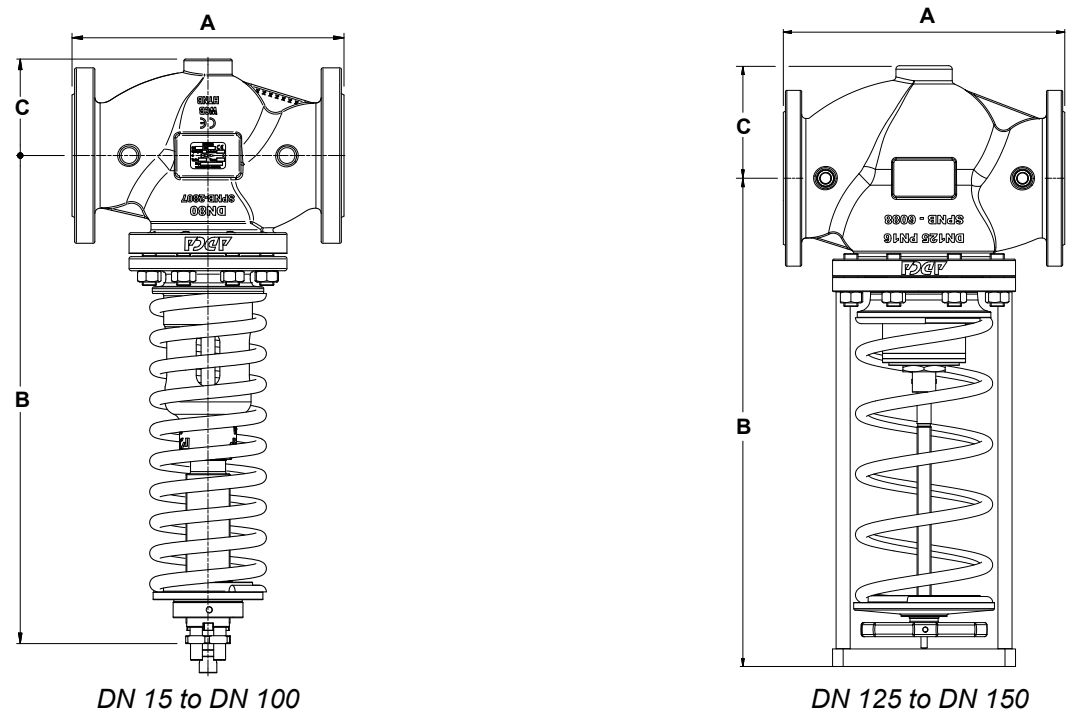

DIMENSIONS – VALVE (mm)											
DIMENSION	SIZE										
	DN 15	DN 20	DN 25	DN 32	DN 40	DN 50	DN 65	DN 80	DN 100	DN 125	DN 150
A	130	150	160	180	200	230	290	310	350	400	480
B	366	366	371	377	384	470	495	556	597	694	710
C	–	–	–	–	–	85	100	110	130	160	180
WEIGHT (kg)	9,5	10,2	11,2	14	15,5	21,7	32,2	45,4	53,3	91,3	113

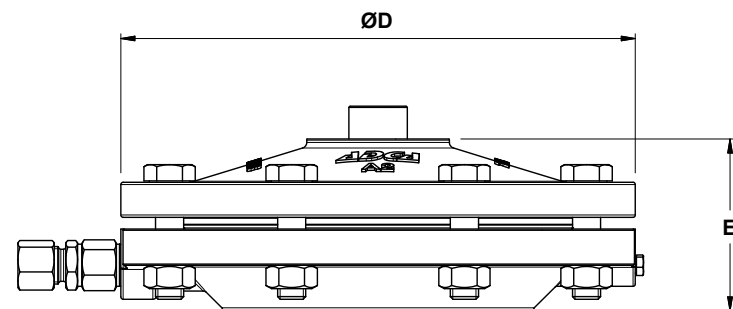

DIMENSIONS – ACTUATOR (mm)														
DIMENSION	ACTUATOR													
	A1 A1i	A10 A10i	A11 A11i	A12 A12i	A2 A2i	A21 A21i	A3 A3i	A4 A4i	B1	B2	B21	B3	B4	C11
ØD	172	172	172	172	220	220	282	340	172	220	220	283	340	145
E	67	67	67	67	74	74	71	81	80	86	86	88	98	93
WEIGHT (kg)	4,3	4,3	4,3	4,3	7,3	7,3	11,3	16,3	4,4	7,4	7,4	11,6	18,6	2,3

MATERIALS

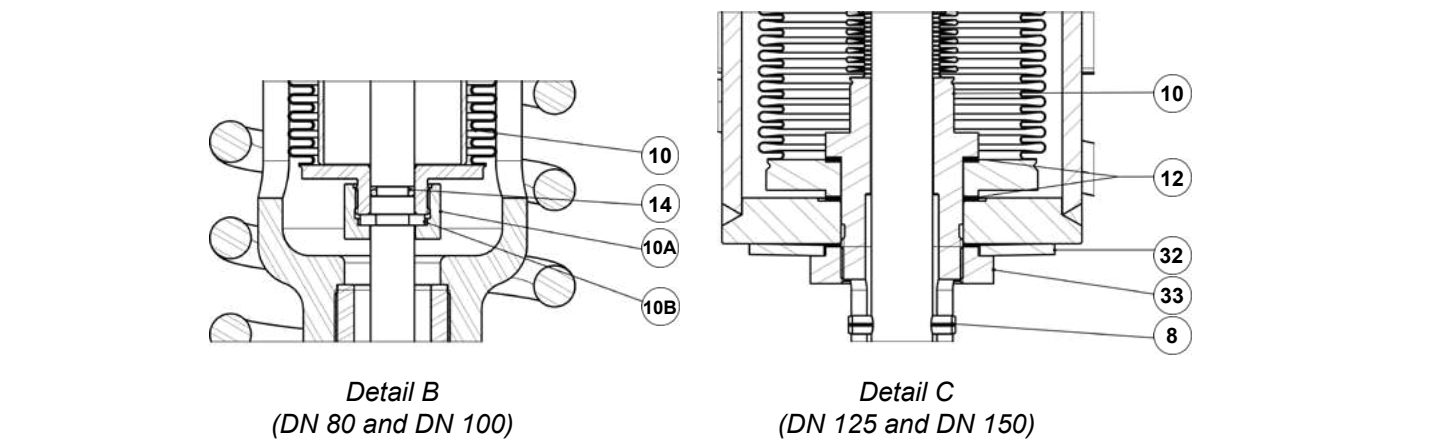
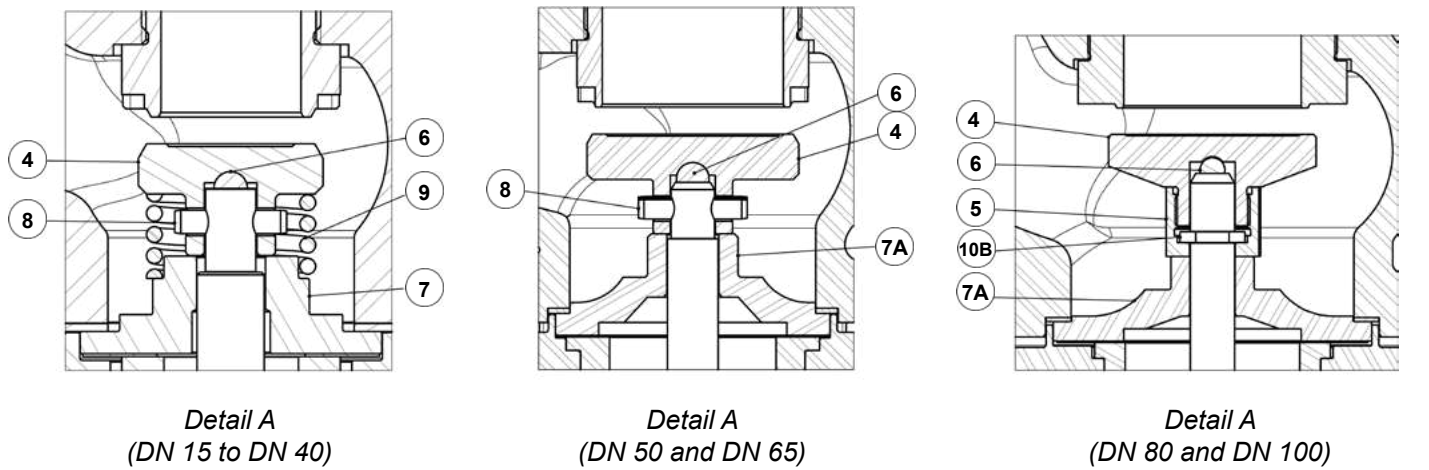
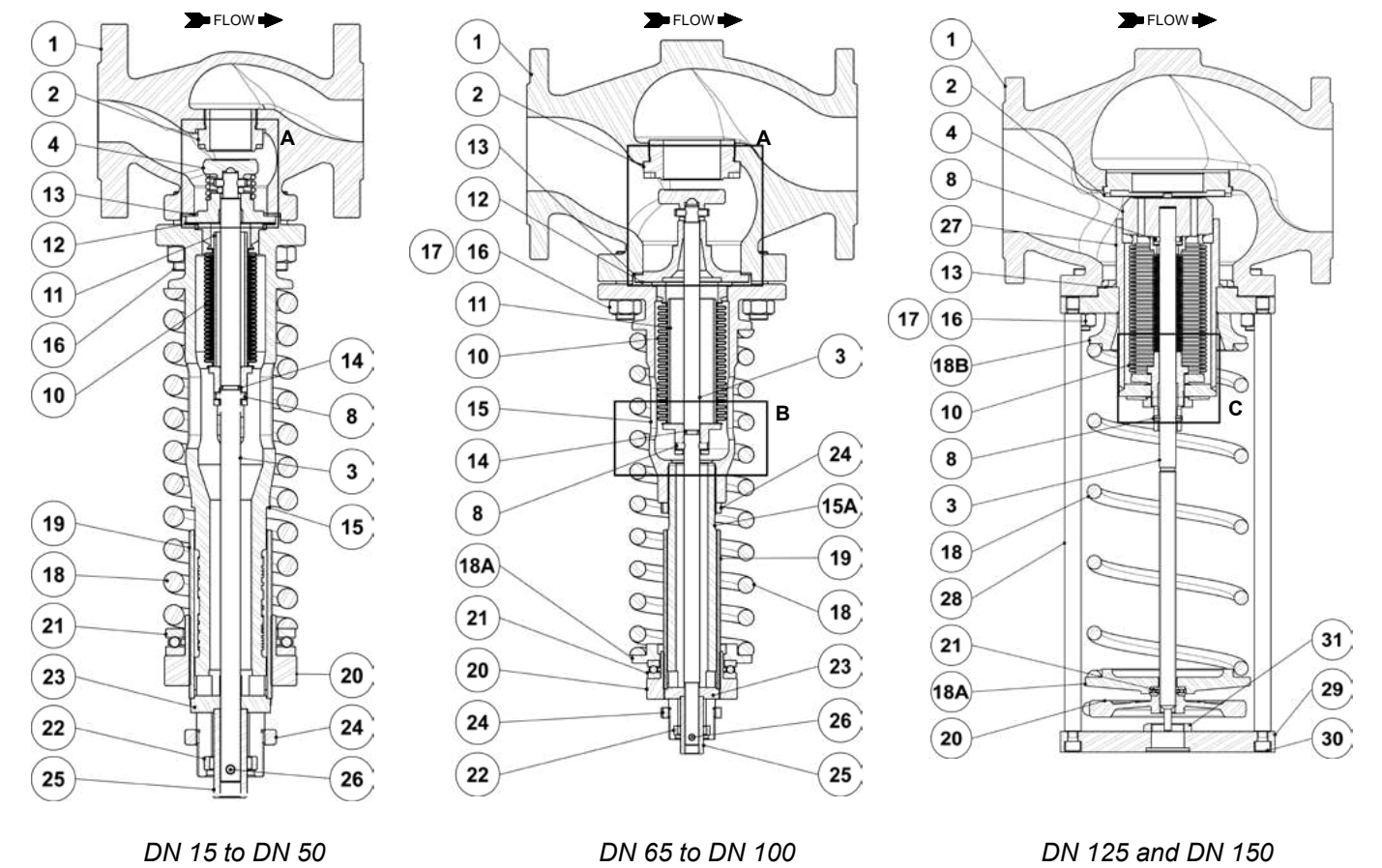

MATERIALS – VALVE			
POS. N°	DESIGNATION	DN 15 to DN 100	DN 125 to DN 150
1	Valve body (RP45G)	GJS-400-15 / 0.7040	GJS-400-15 / 0.7040
	Valve body (RP45S)	A216 WCB / 1.0619	A216 WCB / 1.0619
	Valve body (RP45i)	A351 CF8M / 1.4408	A351 CF8M / 1.4408
2	Seat	AISI 316 / 4.4401	AISI 316 / 4.4401
3	Stem	AISI 304 / 1.4301	AISI 304 / 1.4301
4	* Valve plug	AISI 420 / 1.4021	AISI 316 / 4.4401
5	Nut	AISI 316 / 1.4401	AISI 316 / 4.4401
6	Ball	AISI 440C / 1.4125	–
7	Stem guide	AISI 304 / 1.4301	–
7A	Stem guide	AISI 304 / 1.4301	–
8	Pin	AISI 301 / 1.4310	AISI 304 / 1.4301
9	Compensating spring	AISI 302 / 1.4300	–
10	* Bellows	AISI 316Ti / 1.4571	AISI 316 / 1.4401
10A	Nut	AISI 316 / 1.4401	–
10B	Split ring	AISI 316 / 1.4401	–
11	Guide tube	CuZn39Pb3	–
12	Bellows gasket	Stainless steel / Graphite	Stainless steel / Graphite
13	Body gasket	Stainless steel / Graphite	Stainless steel / Graphite
14	O-ring	EPDM	–
15	Piston body (RP45G and RP45S)	A216 WCB / 1.0619	–
	Piston body (RP45i)	A351 CF8M / 1.4408	–
15A	Piston body extension (RP45G and RP45S)	P355T1 / 1.0421	–
	Piston body extension (RP45i)	AISI 304 / 1.4301	–
16	Studs (RP45G and RP45S)	Steel 8.8; EN 10269 steel	Steel 8.8; EN 10269 steel
	Studs (RP45i)	Stainless steel A2-70	–
17	Nuts (RP45G and RP45S)	Steel 8.8; EN 10269 steel	Steel 8.8; EN 10269 steel
	Nuts (RP45i)	Stainless steel A2-70	–
18	* Adjustment spring	Spring steel	Spring steel
18A	Lower spring plate (RP45G and RP45S)	C45E / 1.1191	A216 WCB / 1.0619
	Lower spring plate (RP45i)	AISI 304 / 1.4301	–
18B	Upper spring plate	–	S235JG2R / 1.0038
19	Threaded tube	CuZn39Pb3	–
20	Spring adjusting nut (RP45G and RP45S)	C45E / 1.1191	A216 WCB / 1.0619
	Spring adjusting nut (RP45i)	AISI 304 / 1.4301	–
21	Ball bearing	Zinc plated steel	Zinc plated steel
22	Spacer (RP45G and RP45S)	S355JR / 1.0045	–
	Spacer (RP45i)	AISI 304 / 1.4301	–
23	Pressure star (RP45G and RP45S)	S235JR / 1.0038	–
	Pressure star (RP45i)	AISI 304 / 1.4301	–
24	Lock nut (RP45G and RP45S)	C45E / 1.1191	–
	Lock nut (RP45i)	AISI 303 / 1.4305	–
25	Pressure tube (RP45G and RP45S)	C45E / 1.1191	–
	Pressure tube (RP45i)	AISI 304 / 1.4301	–
26	Pin	AISI 303 / 1.4305	–
27	Bellows housing	–	S355JR / 1.0045
28	Pillars	–	C45E / 1.1191
29	Pillars flange	–	C45E / 1.1191
30	Bolts	–	Zinc plated steel
31	Stem nut	–	A351 CF8 / 1.4308
32	Belleville washer	–	P235GH / 1.0345
33	Tightening nut	–	S235JR / 1.0038

* Available spare parts.

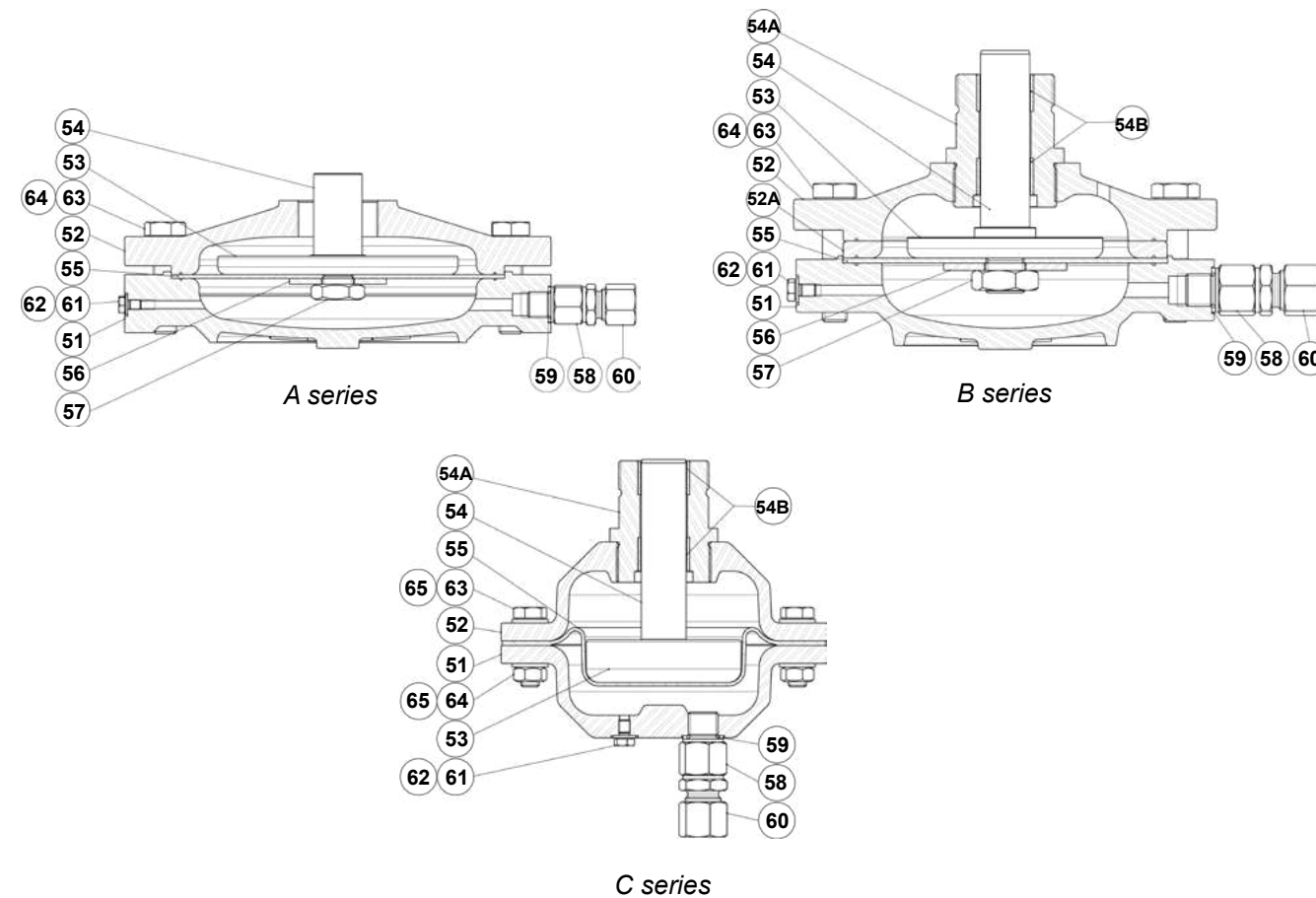

MATERIALS – ACTUATOR							
POS. N°	DESIGNATION	A1, A10, A11, A12, A3 and A4	A2 and A21	A1i, A10i, A11i, A12i, A2i, A21i, A3i and A4i	B1, B3 and B4	B2 and B21	C11
51	Lower diaph. chamber	A216 WCB / 1.0619	GJS-400-15 / 0.7040 A216 WCB / 1.0619	A351 CF8M / 1.4408	A216 WCB / 1.0619	GJS-400-15 / 0.7040 A216 WCB / 1.0619	S235JR / 1.0038
52	Upper diaph. chamber	A216 WCB / 1.0619	GJS-400-15 / 0.7040 A216 WCB / 1.0619	A351 CF8M / 1.4408	A216 WCB / 1.0619	GJS-400-15 / 0.7040 A216 WCB / 1.0619	S235JR / 1.0038
52A	Spacer ring	–	–	–	S355JR / 1.0045	S355JR / 1.0045	–
53	Pressure plate	A216 WCB / 1.0619	GJS-400-15 / 0.7040	A351 CF8M / 1.4408 AISI 304 / 1.4301	S355JR / 1.0045	S355JR / 1.0045	C45E / 1.1191
54	Diaph. plate spindle	A216 WCB / 1.0619	GJS-400-15 / 0.7040	A351 CF8M / 1.4408 AISI 304 / 1.4301	AISI 420 / 1.4021	AISI 420 / 1.4021	AISI 420 / 1.4021
54A	Guide	–	–	–	C45E / 1.1191	C45E / 1.1191	C45E / 1.1191
54B	* Plain bearing	–	–	–	Bronze	Bronze	Bronze
55	* Diaphragm	Neoprene reinforced polyamid	Neoprene reinforced polyamid	Neoprene reinforced polyamid	Neoprene reinforced polyamid	Neoprene reinforced polyamid	Reinforced NBR
56	Washer	Copper	Copper	AISI 304 / 1.4301	Copper	Copper	–
57	Hex nut	CuZn39Pb3	CuZn39Pb3	AISI 304 / 1.4301	CuZn39Pb3	CuZn39Pb3	–
58	Flow restrictor	AISI 303 / 1.4305	AISI 303 / 1.4305	AISI 303 / 1.4305	AISI 303 / 1.4305	AISI 303 / 1.4305	AISI 303 / 1.4305
59	Gasket	Copper	Copper	Copper	Copper	Copper	Copper
60	Compression fitting	AISI 316Ti / 1.4571	AISI 316Ti / 1.4571	AISI 316Ti / 1.4571	AISI 316Ti / 1.4571	AISI 316Ti / 1.4571	AISI 316Ti / 1.4571
61	Vent screw	Zinc plated steel	Zinc plated steel	AISI 304 / 1.4301	Zinc plated steel	Zinc plated steel	Zinc plated steel
62	Washer	Copper	Copper	AISI 304 / 1.4301	Copper	Copper	Copper
63	Bolts	Zinc plated steel	Zinc plated steel	AISI 304 / 1.4301	Zinc plated steel	Zinc plated steel	Zinc plated steel
64	Nuts	Zinc plated steel	Zinc plated steel	AISI 304 / 1.4301	Zinc plated steel	Zinc plated steel	Zinc plated steel
65	Washer	–	–	–	–	–	Zinc plated steel

* Available spare parts.

PRESSURE REDUCING VALVE RP45 (ASME)

DESCRIPTION

The ADCA RP45 series pressure reducing valves are single seated, bellows sealed controllers that operate without auxiliary energy. Designed for use with steam, compressed air, and other gases compatible with the construction. These valves are particularly suitable for reducing steam pressure in all energy and process systems where pressures must be kept under control.

MAIN FEATURES

Specially designed high durability bellows, providing pressure balancing and frictionless plug stem.
Robust construction (fit-and-forget).
Suitable for use with high pressure turndowns.
Interchangeable actuators and adjustment springs.

OPTIONS: Soft sealing in PTFE/GR for use with steam.
Soft sealing in nitrile rubber for use with air and gases.
Low-noise flow divider.
Sensing pipe on body.

USE: Steam, compressed air and other gases compatible with the construction. Limited use with liquids. Consult manufacturer before installing the valve with liquids.

AVAILABLE MODELS: RP45S and RP45ST or N – carbon steel.
Suffix T: soft sealed with PTFE/GR.
Suffix N: soft sealed with nitrile rubber.

SIZES: 1/2" to 6".

CONNECTIONS: Flanged ASME B16.5 Class 150 or 300.

AVAILABLE ACTUATORS: A1, A10, A11, A12, A3, A4, B1, B3, B4 and C11 – carbon steel.
A2, A21, B2 and B21 – SG iron or carbon steel.

INSTALLATION: See IMI – Installation and maintenance instructions.



**RP45
1/2" to 4"**

**RP45
6"**



**RP45
1/2" to 4"
with sensing pipe
on body**

CE MARKING – GROUP 2 (PED – European Directive)		
Class 150	Class 300	Category
1/2" to 2"	1/2" to 1"	SEP
2 1/2" to 4"	1 1/2" to 4"	1 (CE marked)
6"	6"	2 (CE marked)

LIMITING CONDITIONS

Valve model	RP45S	RP45S	RP45ST	RP45ST	RP45SN	RP45SN
Body design conditions	Class 150	Class 300	Class 150	Class 300	Class 150	Class 300
Maximum upstream pressure	13 bar	25 bar	13 bar	25 bar	13 bar	25 bar
Maximum downstream pressure (1/2" to 4")	13 bar	18 bar	13 bar	18 bar	13 bar	18 bar
Maximum downstream pressure (6")	12 bar	16,5 bar	12 bar	16,5 bar	12 bar	16,5 bar
Minimum downstream pressure	0,15 bar	0,15 bar	0,15 bar	0,15 bar	0,15 bar	0,15 bar
Maximum operating temperature	200 °C	250 °C	200 °C	200 °C	80 °C	80 °C
Maximum reducing ratio	25:1	25:1	25:1	25:1	10:1	10:1
Rangeability	10:1	10:1	10:1	10:1	10:1	10:1
Maximum hydraulic factory valve body test	24 bar	60 bar	24 bar	60 bar	24 bar	60 bar

Remark: Other soft materials and temperature limits on request.

Actuator model	A1	A10	A11	A12	A2	A21	A3	A4	B1	B2	B21	B3	B4	C11
Maximum operating pressure (bar)	25	25	25	25	12	18	2,5	1,5	25	13	18	2,5	1,5	25
Maximum operating temperature	90 °C *													

* The water seal pot must be installed in the sensing pipe when operating with steam or liquids at higher temperatures.

FLOW RATE COEFFICIENTS (m³/h)

SIZE	1/2"	3/4"	1"	1 1/2"	2"	2 1/2"	3"	4"	6"
Kvs	4,8	6,9	9,1	14,4	26,5	51,5	79,5	129,5	204

SATURATED STEAM CAPACITY TABLE (kg/h)

INLET (barg)	SIZE								
	1/2"	3/4"	1"	1 1/2"	2"	2 1/2"	3"	4"	6"
0,5	51	68	90	186	300	460	800	1250	1800
0,75	63	84	112	230	360	580	1000	1550	2350
1	75	100	133	280	430	700	1200	1850	3200
1,5	100	133	175	360	590	910	1600	2500	4000
2	126	170	230	450	730	1160	2000	3050	4700
2,5	150	200	260	550	880	1390	2400	3600	6500
3	175	240	310	640	1010	1600	2700	4300	8500
4	220	290	390	800	1300	2000	3400	5400	10000
5	260	350	480	1000	1600	2500	4200	6500	12000
6	330	440	580	1220	1930	3000	5100	8000	14000
7	400	520	700	1430	2300	3600	6100	9500	16000
8	450	600	800	1670	2700	4100	7100	11000	18000
9	500	670	880	1800	2900	4600	7800	12000	20000
10	560	750	980	2000	3200	5100	8500	13500	22000
12	680	900	1180	2500	4000	6100	10500	16300	25000
14	800	1050	1400	2900	4700	7200	12600	19000	29000
16	920	1230	1630	3400	5500	8300	14600	22000	33000
18	1040	1400	1860	3800	6200	9500	16600	25000	38000
20	1170	1540	2100	4200	7000	10800	18600	28000	42000
22	1330	1780	2350	4900	7800	12200	21000	32000	45000
24	1500	2000	2600	5400	8700	13700	23500	36000	48000
25	1600	2150	2800	5700	9200	14500	25500	38000	50000

Remark: For pressure ratios where P2 > 0,7 P1 and/or when the operating medium is superheated steam, a correction factor must be applied. See next page.



CORRECTION FACTORS

Pressure ratio:

The capacities given in the "Saturated steam capacity table" are applicable in scenarios where $P2 < 0,7 P1$. In the remaining scenarios a correction factor must be applied:

PRESSURE RATIO * P2 / P1	CORRECTION FACTOR f
≥ 0,7	1,25
≥ 0,8	1,6
≥ 0,9	2,25

* Pressure ratio in bar abs (barg + 1)

Superheated steam:

When the medium is superheated steam, instead of saturated steam, a correction factor must also be applied. The required mass flow must be multiplied by the following factor:

$\frac{V_h}{V_s}$, where V_h = specific volume of superheated steam, and
 V_s = specific volume of saturated steam.

ACTUATOR AND SPRING SELECTION TABLE																	
SIZE		ACTUATOR															
		A4	A3	A2	A21	A1	A10	A11	A12	B4	B3	B2	B21	B1	C11		
1/2"	Regulating range (bar)	0,15 to 0,49	0,5 to 0,99	1,0 to 1,6	1,7 to 3,8	3,9 to 5,5	5,6 to 8,2	-	-	8,3 to 13	10 to 18	-	-	-	-	-	
	Spring N°	66	60	60	60	60	60	-	-	60	60.1	-	-	-	-	-	
3/4"	Regulating range (bar)	0,15 to 0,49	0,5 to 0,99	1 to 1,6	1,7 to 3,8	3,9 to 5,5	5,6 to 8,2	-	-	8,3 to 13	10 to 18	-	-	-	-	-	
	Spring N°	66	60	60	60	60	60	-	-	60	60.1	-	-	-	-	-	
1"	Regulating range (bar)	0,15 to 0,49	0,5 to 0,99	1 to 1,6	1,7 to 3,8	3,9 to 5,5	5,6 to 8,2	-	-	8,3 to 13	10 to 18	-	-	-	-	-	
	Spring N°	66	60	60	60	60	60	-	-	60	60.1	-	-	-	-	-	
1 1/2"	Regulating range (bar)	0,15 to 0,49	0,5 to 0,99	1 to 1,6	1,7 to 3,8	3,9 to 5,5	5,6 to 8,2	-	-	8,3 to 13	10 to 18	-	-	-	-	-	
	Spring N°	66	60	60	60	60	60	-	-	60	60.1	-	-	-	-	-	
2"	Regulating range (bar)	0,15 to 0,49	0,5 to 0,99	1 to 1,9	2 to 4,2	4,3 to 6,9	7 to 8,5	-	10 to 18	8,6 to 13	-	-	-	-	-	-	
	Spring N°	67	61	61	61	61	64	-	61	64	-	-	-	-	-	-	
2 1/2"	Regulating range (bar)	0,15 to 0,49	0,5 to 0,99	1 to 1,9	2 to 4,2	4,3 to 6,9	7 to 8,5	-	10 to 18	8,6 to 13	-	-	-	-	-	-	
	Spring N°	67	61	61	61	61	64	-	61	64	-	-	-	-	-	-	
3"	Regulating range (bar)	0,15 to 0,45	0,46 to 0,99	1 to 1,9	2 to 5	5,1 to 8,9	9 to 13	11 to 18	-	-	-	-	-	-	-	-	
	Spring N°	68	62	62	62	62	65	62	-	-	-	-	-	-	-	-	
4"	Regulating range (bar)	0,15 to 0,45	0,46 to 0,99	1 to 1,9	2 to 6,0	6,1 to 13	-	11 to 18	-	-	-	-	-	-	-	-	
	Spring N°	69	63	63	63	63	-	63	-	-	-	-	-	-	-	-	
6"	Regulating range (bar)	-	-	-	-	-	-	-	-	-	-	0,5 to 1,5	1,1 to 2,5	1,5 to 5,5	4 to 8,5	6 to 12	8 to 16,5
	Spring N°	-	-	-	-	-	-	-	-	-	-	70	70	70	70	70	70



HOW TO SIZE (USING STEAM TABLE)

Example

Required saturated steam capacity: 500 kg/h; Upstream pressure: 3 bar; Required downstream pressure: 2 bar.

Solution:

First determine correction factor for pressure ratio: $(2+1) / (3+1) = 0,75 \rightarrow f = 1,25$

Then multiply the given capacity: $500 \times 1,25 = 625 \text{ kg/h}$

Afterwards, refer to the cell with the number "3" in the column "INLET" of the saturated steam capacity table. In that line, the values for selection of the pressure reducing valve size can be found. In this particular scenario, a value equal to or higher than 625 kg/h is required, and the right selection would be 1 1/2", with a capacity of 640 kg/h.

On the actuator and spring selection table, for a downstream pressure of 2 bar, the recommended actuator is the A2, and the regulating spring is N° 60.

Remarks: Never size the valve according to the pipe diameter in which it has to be fitted, but according to the actual flow required. Pipe sizing must also respect the maximum recommended flow velocities, according to the medium.

HOW TO SIZE (USING Kvs)

Please consult formulas on IS PV10.00 E or consult manufacturer.

HOW TO ORDER

RP45S 1 1/2" Class 150 valve complete with spring N° 60, A2 actuator, condensate vessel and copper sensing pipe.

INSTALLATION

Horizontal installation with the actuator vertically, pointing downwards.

Installation with the actuator pointing upwards is possible only when the medium temperature is below 90 °C.

The sensing pipe, if not fitted on the valve body, must be installed downstream of the valve at a minimum of 1 meter away or 15 pipe diameters.

In steam applications, a "Y" strainer, humidity separator and steam trap should be installed upstream of the valve.

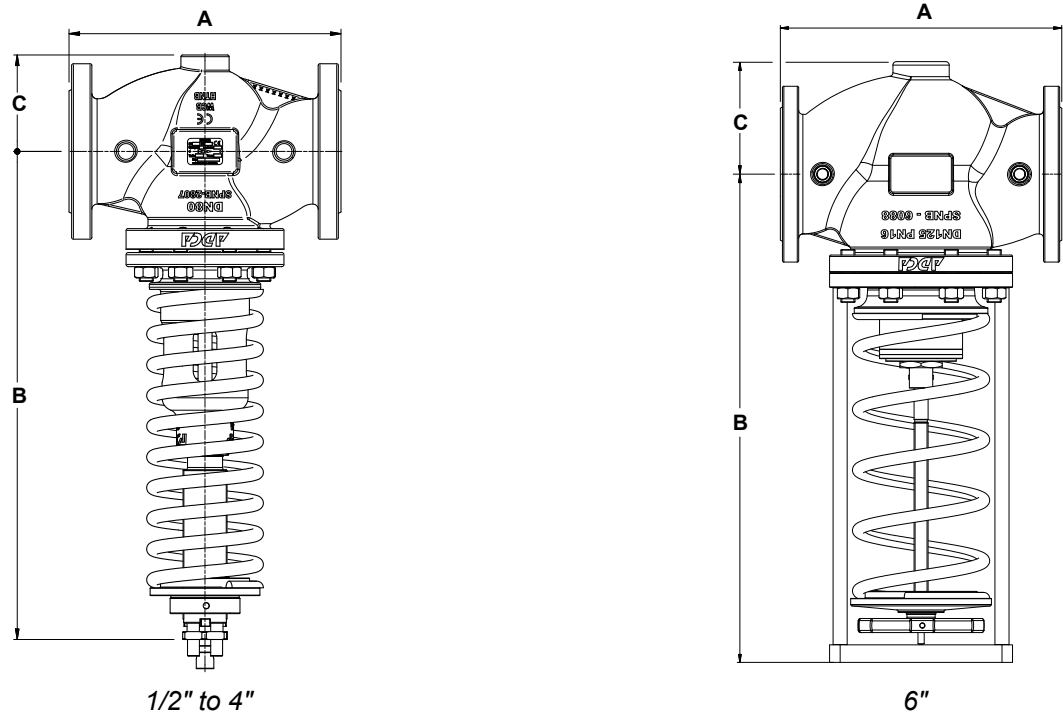

DIMENSIONS – VALVE (mm)										
DIMENSION	CLASS	SIZE								
		1/2"	3/4"	1"	1 1/2"	2"	2 1/2"	3"	4"	6"
A	CLASS 150	184	184	184	222	254	276	298	352	451
	CLASS 300	190	194	197	235	267	292	318	368	473
B	CLASS 150	366	366	371	384	470	495	556	597	710
	CLASS 300	366	366	371	384	470	495	556	597	710
C	CLASS 150	44,5	49	54	65	85	100	110	130	180
	CLASS 300	47,5	58,5	62	78	85	100	110	130	180
WGT. (kg)	CLASS 150	8,9	9,2	10,4	14	20,5	29,9	42,2	55	113
	CLASS 300	9,3	10,2	11,8	16,8	22,8	33	47,5	62,9	129,4

Remarks: In the beginning of year 2022 new face to face dimensions have been defined for some Class 150 valves. Valves may still be supplied with the previous face to face dimensions under request. Consult the manufacturer.

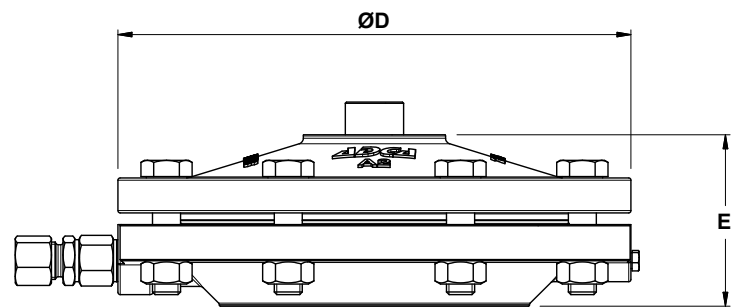

DIMENSIONS – ACTUATOR (mm)														
DIMENSION	ACTUATOR													
	A1	A10	A11	A12	A2	A21	A3	A4	B1	B2	B21	B3	B4	C11
ØD	172	172	172	172	220	220	282	340	172	220	220	283	340	145
E	67	67	67	67	74	74	71	81	80	86	86	88	98	93
WEIGHT (kg)	4,3	4,3	4,3	4,3	7,3	7,3	11,3	16,3	4,4	7,4	7,4	11,6	18,6	2,3

MATERIALS

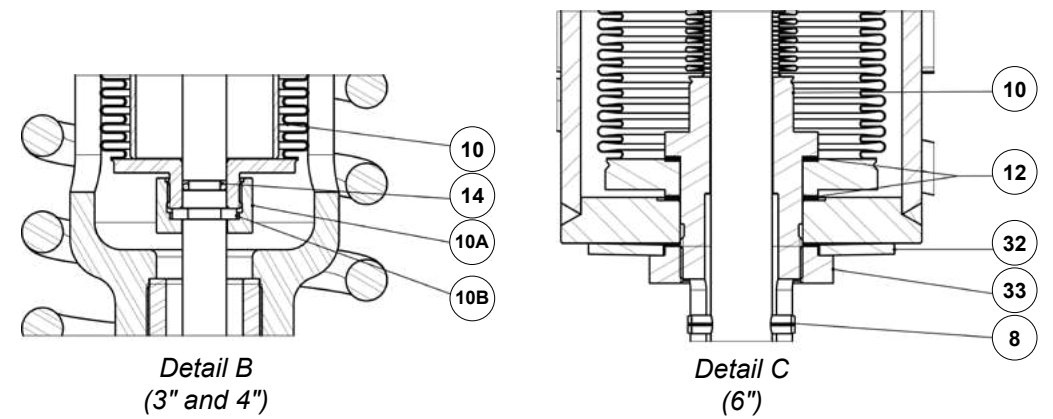
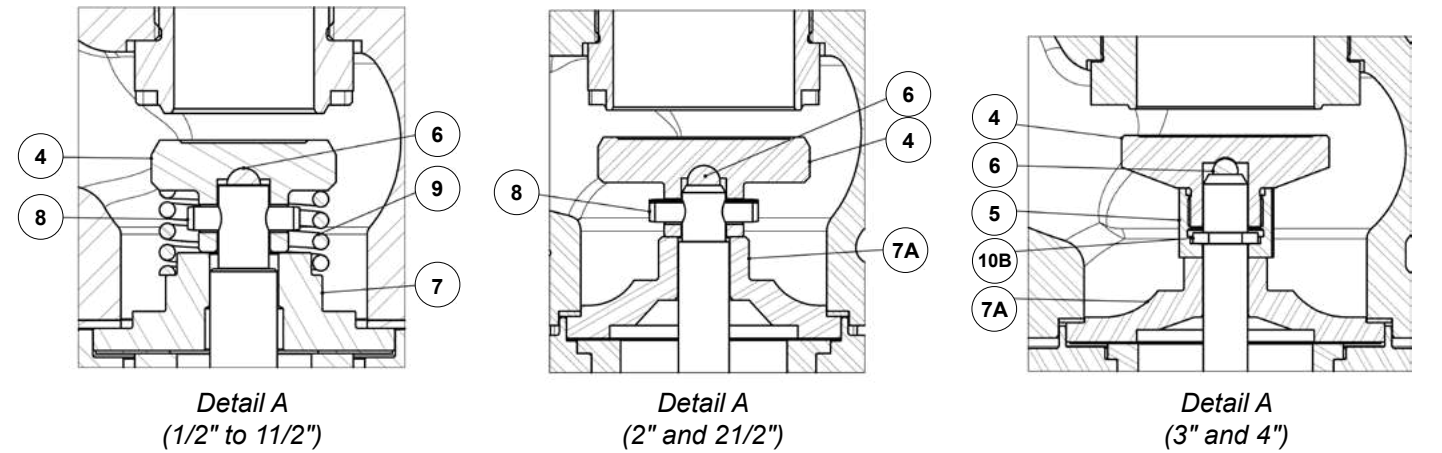
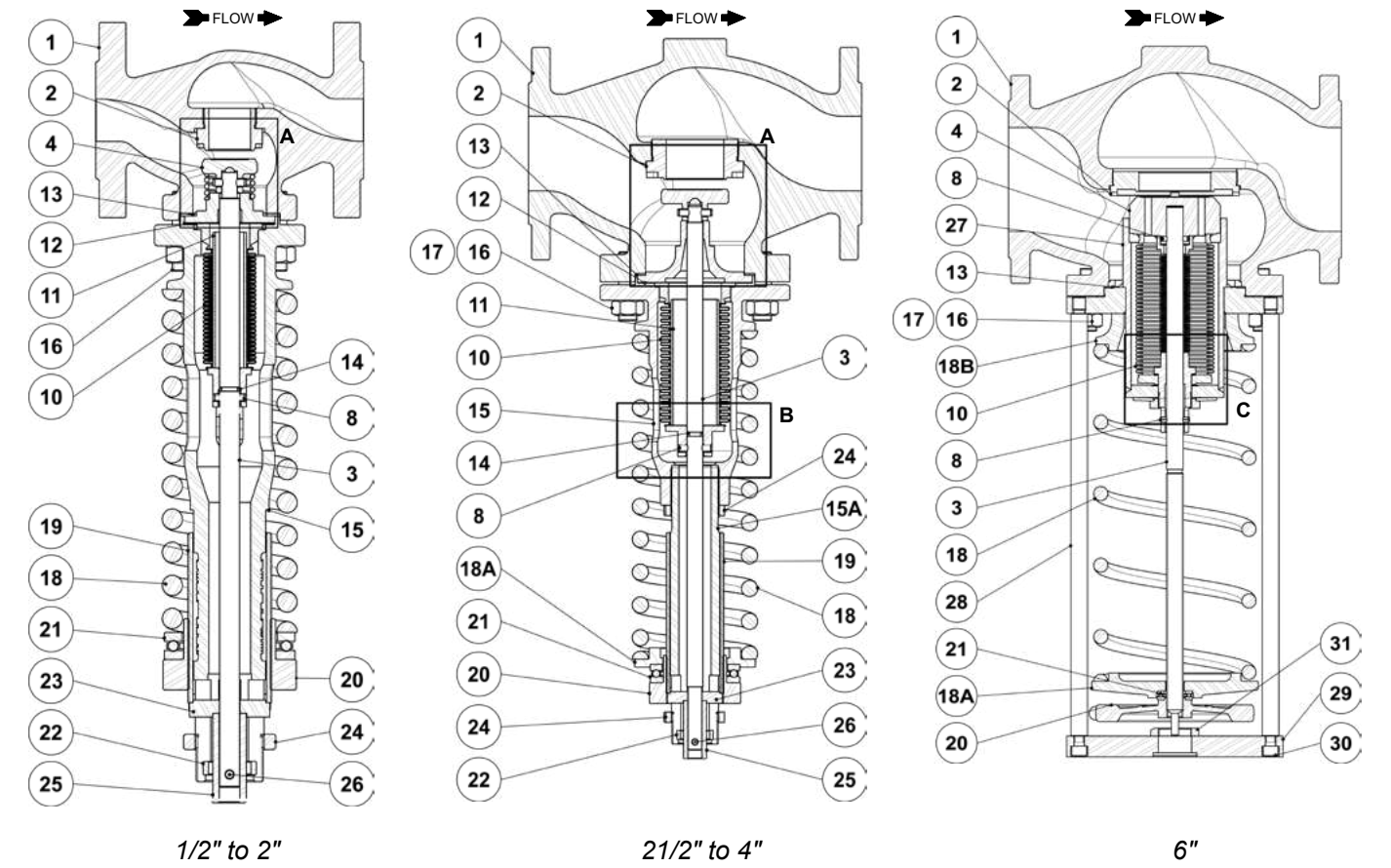

MATERIALS – VALVE			
POS. N°	DESIGNATION	1/2" to 4"	6"
1	Valve body	A216 WCB / 1.0619	A216 WCB / 1.0619
2	Seat	AISI 316 / 4.4401	AISI 316 / 4.4401
3	Stem	AISI 304 / 1.4301	AISI 304 / 1.4301
4	* Valve plug	AISI 420 / 1.4021	AISI 316 / 4.4401
5	Nut	AISI 316 / 1.4401	AISI 316 / 4.4401
6	Ball	AISI 440C / 1.4125	–
7	Stem guide	AISI 304 / 1.4301	–
7A	Stem guide	AISI 304 / 1.4301	–
8	Pin	AISI 301 / 1.4310	AISI 304 / 1.4301
9	Compensating spring	AISI 302 / 1.4300	–
10	* Bellows	AISI 316Ti / 1.4571	AISI 316 / 1.4401
10A	Nut	AISI 316 / 1.4401	–
10B	Split ring	AISI 316 / 1.4401	–
11	Guide tube	CuZn39Pb3	–
12	Bellows gasket	Stainless steel / Graphite	Stainless steel / Graphite
13	Body gasket	Stainless steel / Graphite	Stainless steel / Graphite
14	O-ring	EPDM	–
15	Piston body	A216 WCB / 1.0619	–
15A	Piston body extension	P355T1 / 1.0421	–
16	Studs	Steel 8.8; EN 10269 steel	Steel 8.8; EN 10269 steel
17	Nuts	Steel 8.8; EN 10269 steel	Steel 8.8; EN 10269 steel
18	* Adjustment spring	Spring steel	Spring steel
18A	Lower spring plate	C45E / 1.1191	A216 WCB / 1.0619
18B	Upper spring plate	–	S235JG2R / 1.0038
19	Threaded tube	CuZn39Pb3	–
20	Spring adjusting nut	C45E / 1.1191	A216 WCB / 1.0619
21	Ball bearing	Zinc plated steel	Zinc plated steel
22	Spacer	S355JR / 1.0045	–
23	Pressure star	S235JR / 1.0038	–
24	Lock nut	C45E / 1.1191	–
25	Pressure tube	C45E / 1.1191	–
26	Pin	AISI 303 / 1.4305	–
27	Bellows housing	–	S355JR / 1.0045
28	Pillars	–	C45E / 1.1191
29	Pillars flange	–	C45E / 1.1191
30	Bolts	–	Zinc plated steel
31	Stem nut	–	A351 CF8 / 1.4308
32	Belleville washer	–	P235GH / 1.0345
33	Tightening nut	–	S235JR / 1.0038

* Available spare parts.

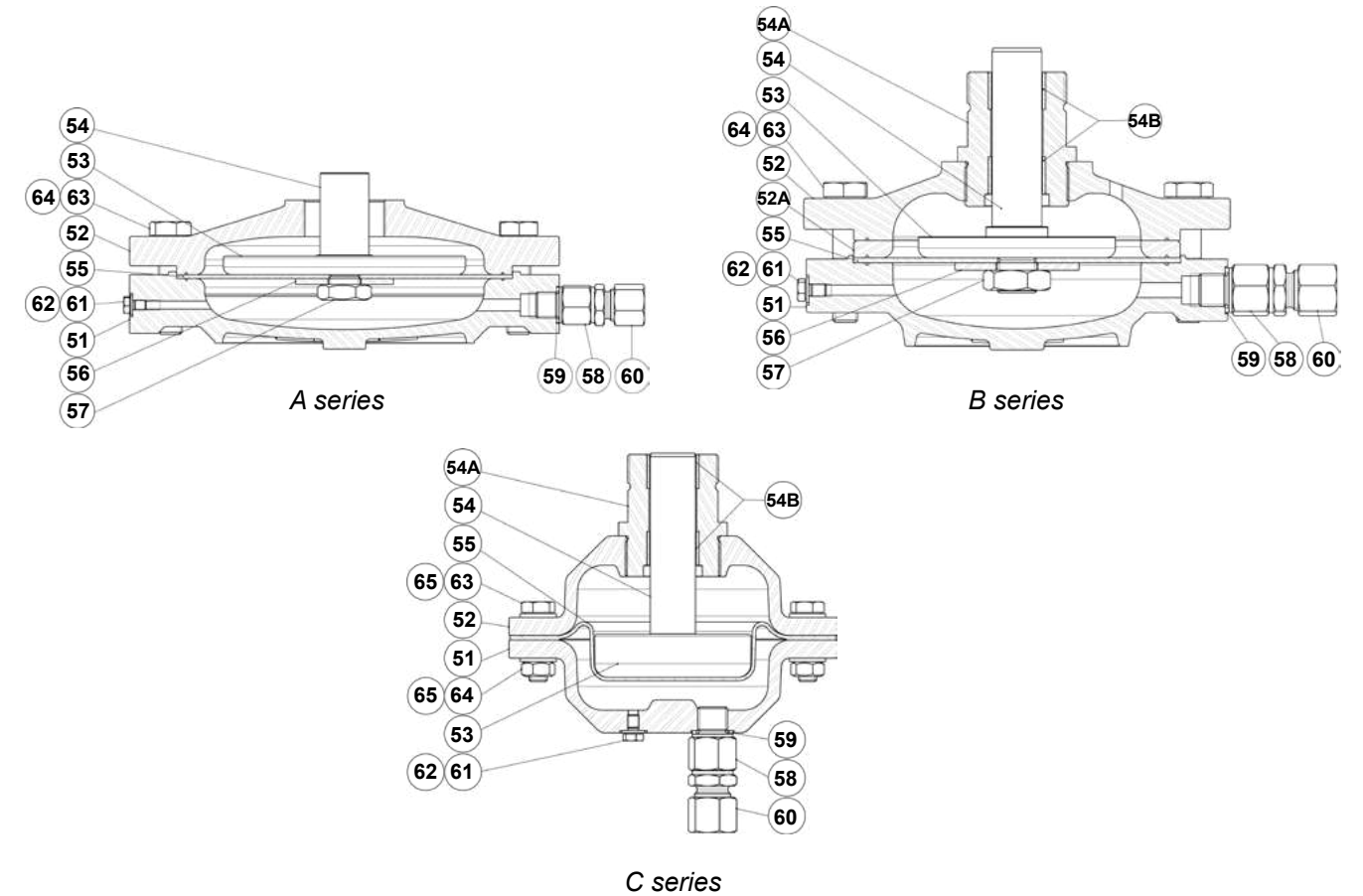

MATERIALS – ACTUATOR						
POS. N°	DESIGNATION	A1, A10, A11, A12, A3 and A4	A2 and A21	B1, B3 and B4	B2 and B21	C11
51	Lower diaphragm chamber	A216 WCB / 1.0619	GJS-400-15 / 0.7040 A216 WCB / 1.0619	A216 WCB / 1.0619	GJS-400-15 / 0.7040 A216 WCB / 1.0619	S235JR / 1.0038
52	Upper diaphragm chamber	A216 WCB / 1.0619	GJS-400-15 / 0.7040 A216 WCB / 1.0619	A216 WCB / 1.0619	GJS-400-15 / 0.7040 A216 WCB / 1.0619	S235JR / 1.0038
52A	Spacer ring	–	–	S355JR / 1.0045	S355JR / 1.0045	–
53	Pressure plate	A216 WCB / 1.0619	GJS-400-15 / 0.7040	S355JR / 1.0045	S355JR / 1.0045	C45E / 1.1191
54	Diaphragm plate spindle	A216 WCB / 1.0619	GJS-400-15 / 0.7040	AISI 420 / 1.4021	AISI 420 / 1.4021	AISI 420 / 1.4021
54A	Guide	–	–	C45E / 1.1191	C45E / 1.1191	C45E / 1.1191
54B	* Plain bearing	–	–	Bronze	Bronze	Bronze
55	* Diaphragm	Neoprene reinforced polyamid	Neoprene reinforced polyamid	Neoprene reinforced polyamid	Neoprene reinforced polyamid	Reinforced NBR
56	Washer	Copper	Copper	Copper	Copper	–
57	Hex nut	CuZn39Pb3	CuZn39Pb3	CuZn39Pb3	CuZn39Pb3	–
58	Flow restrictor	AISI 303 / 1.4305	AISI 303 / 1.4305	AISI 303 / 1.4305	AISI 303 / 1.4305	AISI 303 / 1.4305
59	Gasket	Copper	Copper	Copper	Copper	Copper
60	Compression fitting	AISI 316Ti / 1.4571	AISI 316Ti / 1.4571	AISI 316Ti / 1.4571	AISI 316Ti / 1.4571	AISI 316Ti / 1.4571
61	Vent screw	Zinc plated steel	Zinc plated steel	Zinc plated steel	Zinc plated steel	Zinc plated steel
62	Washer	Copper	Copper	Copper	Copper	Copper
63	Bolts	Zinc plated steel	Zinc plated steel	Zinc plated steel	Zinc plated steel	Zinc plated steel
64	Nuts	Zinc plated steel	Zinc plated steel	Zinc plated steel	Zinc plated steel	Zinc plated steel
65	Washer	–	–	–	–	Zinc plated steel

* Available spare parts.

WATER SEAL POT POT

DESCRIPTION

The ADCA POT is specially designed to protect diaphragms, such as the ones installed in the RP45 pressure regulators, when the media temperature exceeds the diaphragm maximum operating temperature.

OPTIONS: Bigger sizes for special applications or when quick pressure or flow rate fluctuations are present.
Different sizes and materials.

USE: Water sealing in pressure regulators (e.g. RP45).

AVAILABLE MODELS:

POT-4S – PN 16, carbon steel.
POT-4SS – PN 16, stainless steel.
POT-41S – PN 40, carbon steel.
POT-41SS – PN 40, stainless steel.

CONNECTIONS: Female threaded ISO 7 Rp 3/8".
(Compression fittings – 3/8" x 10).

INSTALLATION: Connection to the steam pipe must be always depressurized when filling the vessel with water, in order to avoid the risk of scalding. Please consult the IMI – Installation and maintenance instructions corresponding to the valve where it will be applied.

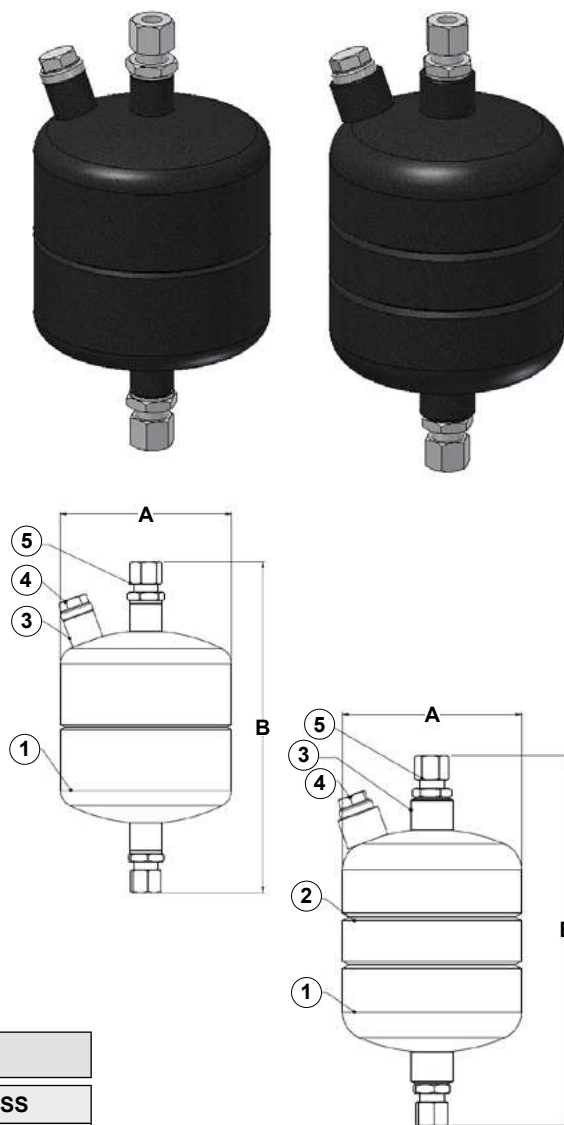

DIMENSIONS (mm)				
MODEL	A	B	VOL. (L)	WGT. (kg)
POT-4S	114	224	1,3	1,9
POT-4SS	114	226	1,3	1,9
POT-41S	114	232	1,3	2,8
POT-41SS	114	221	1,2	2,6

CE MARKING – GROUP 2 (PED – European Directive)

PN 40	Category
3/8"	SEP

BODY LIMITING CONDITIONS *

POT-4S		POT-4SS		POT-41S		POT-41SS	
PN 16		PN 16		PN 40		PN 40	
ALLOW. PRESS.	RELATED TEMP.	ALLOW. PRESS.	RELATED TEMP.	ALLOW. PRESS.	RELATED TEMP.	ALLOW. PRESS.	RELATED TEMP.
16 bar	50 °C	16 bar	50 °C	40 bar	50 °C	40 bar	50 °C
14 bar	100 °C	16 bar	100 °C	37 bar	100 °C	37,9 bar	100 °C
13 bar **	195 °C	13 bar **	195 °C	31 bar **	239 °C	29,9 bar **	250 °C
12 bar	250 °C	12 bar	250 °C	27 bar	300 °C	27,6 bar	300 °C

* Rating according to EN 1092-1:2018; ** PMO – Max. operating pressure for saturated steam. Design code: AD-Merkblatt.

MATERIALS

POS. N°	DESIGNATION	POT-4S	POT-4SS	POT-41S
1	Heads	S235JR / 1.0038	A403 WP316L	EN 10028-2 / P265GH / 1.0425
2	Intermediate tube	–	A312 TP316L	EN 10216-2 / P235GH / 1.0325
3	Sockets	A105 / 1.0432	AISI 316 / 1.4401	S355JR / 1.0045
4	Plug	A105 / 1.0432	AISI 316 / 1.4401	A105 / 1.0432
5	Compression fitting	Fe/Zn – ISO 2081 – Cl. L	AISI 316Ti / 1.4571 – Cl. L	Fe/Zn – ISO 2081 – Cl. L

PRESSURE REDUCING VALVE STATION RP45TW

DESCRIPTION

The ADCA RP45TW series pressure reducing station consists of two standard RP45 valves installed in parallel. This system is particularly recommended for installations where a single valve cannot reach the maximum required flow rate or when the consumption variation is significant, being prudent to install two smaller valves instead of a single one in order to avoid oversizing.

This system is also recommended when it is vital that the steam supply is not interrupted.

OPERATION

Each valve operates individually, according to the description on the RP45 datasheet. This assembly also allows that one of the valves is regulated to a slightly different pressure than the other, avoiding oversizing problems when the consumption variation is significant. In this case, one of the valves remains closed, opening only when the consumption increase justifies it.

MAIN FEATURES

The main characteristic of this assembly is the use of an S252/F humidity separator (see IS 9.315 E) which, besides the separator function, also includes a strainer and has the particularity of having one inlet and two outlets. Compact design.

OPTIONS: Different valve combinations, fittings and designs.

USE: Steam, compressed air and other gases and liquids compatible with the construction.

SIZES: S252/F separator – DN 15 to DN 300.
Pressure regulator – DN 15 to DN 100.

CONNECTIONS: Flanged EN PN 16 or PN 40.
Flanged ASME Class 150 or Class 300.

INSTALLATION: Horizontal installation (see ADCR.05.4805).
Special designs on request.

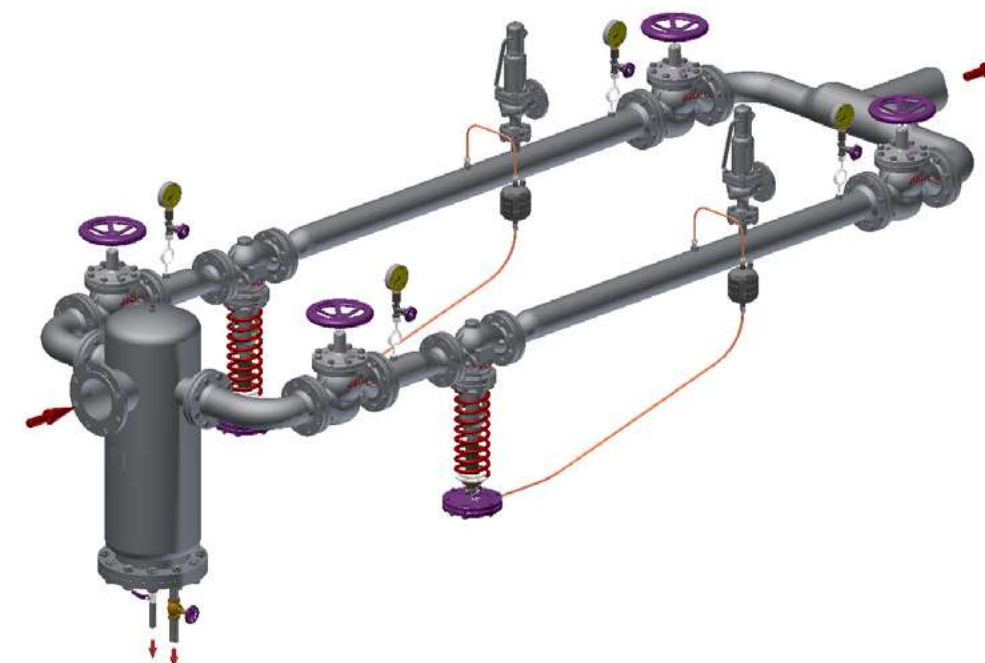

**PRESSURE REDUCING VALVE
RPW45B
(EN)**

DESCRIPTION

The ADCA RPW45B series pressure reducing valves are single seated, diaphragm sensing proportional controllers that operate without auxiliary energy. Designed for use with water, compressed air and other liquids and gases compatible with the construction.

MAIN FEATURES

Pressure balancing through robust piston design.
Soft sealing to meet tight shut-off requirements.
Robust construction (fit-and-forget).
Interchangeable actuators and adjustment springs.

OPTIONS: Low-noise flow divider.
Sensing pipe on body.

USE: Water, compressed air and other liquids or gases compatible with the construction.

AVAILABLE MODELS: RPW45BG – SG iron.
RPW45BS – carbon steel.
RPW45Bi – stainless steel.

SIZES: DN 50 to DN 100.

CONNECTIONS: Flanged EN 1092-1 PN 16 or PN 40. Standard PN 16 DN 65 flanges are supplied with 4 holes. 8 holes, according to EN 1092-1/-2 on request.

AVAILABLE ACTUATORS: A1, A10, A12, A3 and A4 – carbon steel.
A2 and A21 – SG iron or carbon steel.
A1i, A10i, A12i, A2i, A21i, A3i and A4i – stainless steel.

INSTALLATION: See IMI – Installation and maintenance instructions.



RPW45BS

RPW45Bi



RPW45BS
with sensing pipe
on body

CE MARKING – GROUP 2 (PED – European Directive)

PN 16	PN 40	Category
DN 50	–	SEP
DN 65 to 100	DN 50 to 100	1 (CE marked)

LIMITING CONDITIONS

Valve model	RPW45BG, RPW45BS and RPW45Bi	RPW45BS and RPW45Bi
Body design conditions	PN 16	PN 40
Maximum upstream pressure	16 bar	40 bar
Maximum downstream pressure	13 bar	18 bar
Minimum downstream pressure	0,2 bar	0,2 bar
Maximum operating temperature	130 °C	130 °C
Maximum reducing ratio	10:1	10:1
Rangeability	10:1	10:1
Maximum hydraulic factory valve body test	24 bar	60 bar

Remark: Other soft materials and temperature limits on request.

Actuator model	A1 A1i	A10 A10i	A12 A1i	A21 A21i	A2 A2i	A3 A3i	A4 A4i
Maximum operating pressure (bar)	25	25	25	18	12	2,5	1,5
Maximum operating temperature	90 °C *						

* With liquids at higher temperature, the sensing pipe should prevent exceeding the maximum operating temperature of the actuator.

FLOW RATE COEFFICIENTS (m³/h)

SIZE	DN 50	DN 65	DN 80	DN 100
Kvs	26,5	51,5	79,5	129,5

ACTUATOR AND SPRING SELECTION TABLE

SIZE		ACTUATOR							
		A4 A4i	A3 A3i	A2 A2i	A21 A21i	A1 A1i	A10 A10i	A12 A12i	
DN 50	Regulating range (bar)	0,2 to 0,5	0,4 to 1	0,7 to 1,6	1,4 to 3,5	2,5 to 5,5	3,5 to 8	5 to 10	8 to 18
	Spring N°	67	61	61	61	61	61	61	61
DN 65	Regulating range (bar)	0,2 to 0,5	0,4 to 1	0,7 to 1,6	1,4 to 3,5	2,5 to 5,5	3,5 to 8	5 to 10	8 to 18
	Spring N°	67	61	61	61	61	61	61	61
DN 80	Regulating range (bar)	0,2 to 0,5	0,4 to 1,2	0,7 to 2	1,8 to 4,5	2,5 to 5,5	3,5 to 9	5 to 12	10 to 18
	Spring N°	68	62	62	62	62	62	62	62
DN 100	Regulating range (bar)	0,2 to 0,6	0,4 to 1,2	0,7 to 2	1,8 to 4,5	2,5 to 5,5	3,5 to 9	5 to 12	10 to 18
	Spring N°	69	63	63	63	63	63	63	63

HOW TO SIZE (USING Kvs)

Please consult formulas on IS PV10.00 E or consult manufacturer.

HOW TO ORDER

RPW45BS DN 80 PN 16 valve complete with spring N° 62, A2 actuator with sensing pipe on body.

INSTALLATION

Horizontal installation with the actuator vertically, pointing downwards (recommended, especially for liquid service) or upwards.

The sensing pipe, if not fitted on the valve body, must be installed downstream of the valve at a minimum of 1 meter away or 15 pipe diameters.

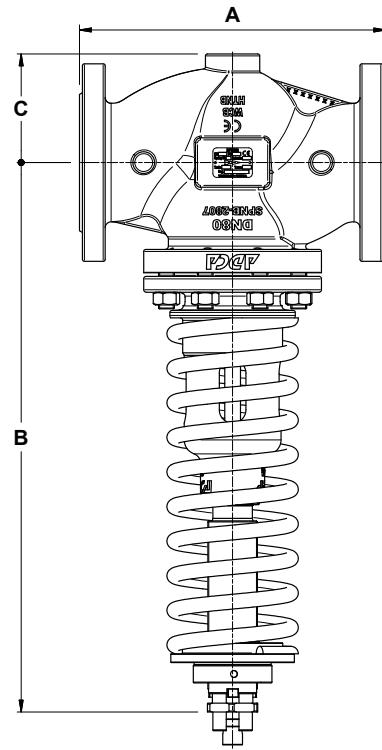

DIMENSIONS - VALVE (mm)				
DIMENSION	SIZE			
	DN 50	DN 65	DN 80	DN 100
A	230	290	310	350
B	470	495	556	597
C	85	100	110	130
WEIGHT (kg)	23,9	37,3	48,1	58,2

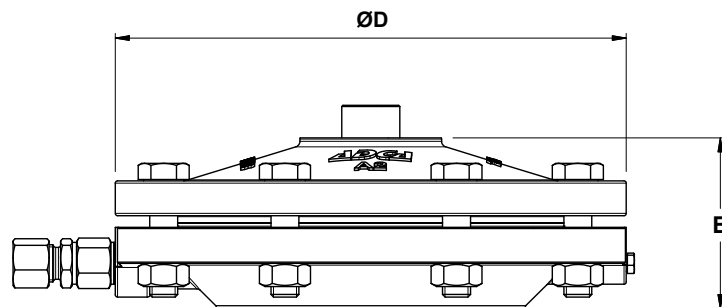

DIMENSIONS - ACTUATOR (mm)							
DIMENSION	ACTUATOR						
	A1 A1i	A10 A10i	A12 A12i	A2 A2i	A21 A21i	A3 A3i	A4 A4i
ØD	172	172	172	220	220	282	340
E	67	67	67	74	74	71	81
WEIGHT (kg)	4,3	4,3	4,3	7,3	7,3	11,3	16,3

MATERIALS

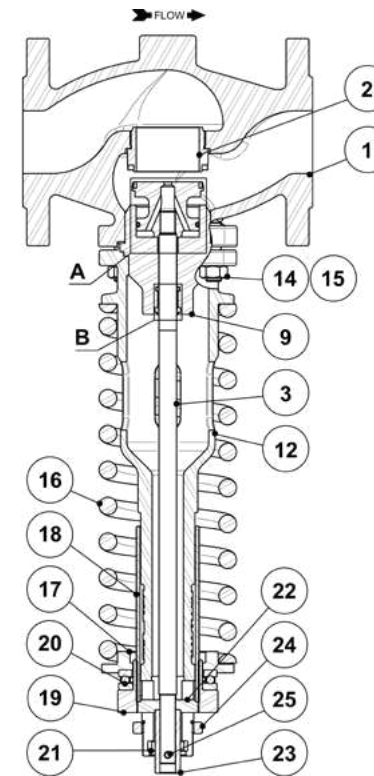

DN 50

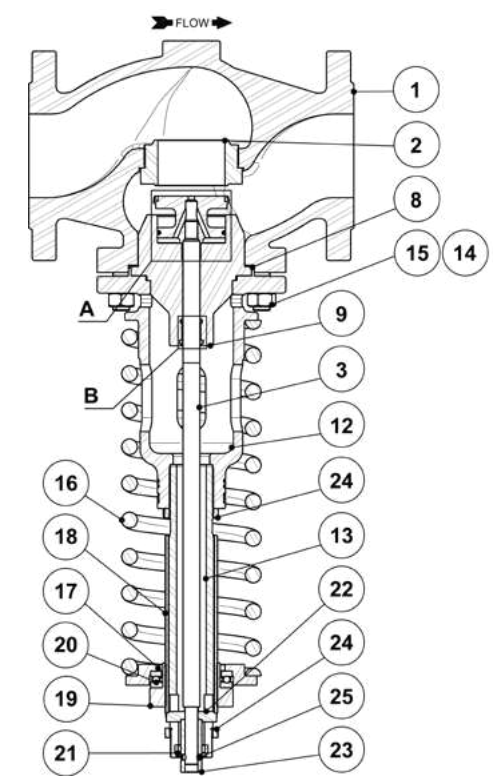

DN 65 to DN 100

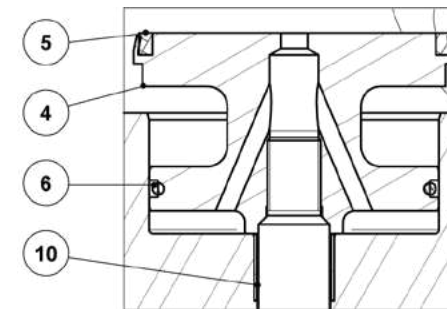

Detail A

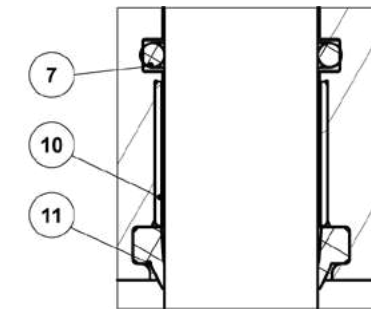

Detail B

MATERIALS – VALVE			
POS. N°	DESIGNATION	DN 50	DN 65 to DN 100
1	Valve body (RPW45BG)	GJS-400-15 / 0.7040	GJS-400-15 / 0.7040
	Valve body (RPW45BS)	A216 WCB / 1.0619	A216 WCB / 1.0619
	Valve body (RPW45Bi)	A351 CF8M / 1.4408	A351 CF8M / 1.4408
2	Seat	AISI 316 / 4.4401	AISI 316 / 4.4401
3	Stem	AISI 304 / 1.4301	AISI 304 / 1.4301
4	* Valve plug	AISI 316 / 4.4401	AISI 316 / 4.4401
5	Seal ring	EPDM	EPDM
6	O-ring	EPDM	EPDM
7	O-ring	EPDM	EPDM
8	Gasket	Stainless steel / Graphite	Stainless steel / Graphite
9	Stem guide	AISI 304 / 1.4301	AISI 304 / 1.4301
10	Guide bushing	Steel	Steel
11	Scraper	Viton	Viton
12	Piston body (RPW45BG and RPW45BS)	A216 WCB / 1.0619	A216 WCB / 1.0619
	Piston body (RPW45Bi)	A351 CF8M / 1.4408	A351 CF8M / 1.4408
13	Piston body extension (RPW45BG and RPW45BS)	–	P355T1 / 1.0421
	Piston body extension (RPW45Bi)	–	AISI 304 / 1.4301
14	Studs (RPW45BG and RPW45BS)	Steel 8.8; EN 10269 steel	Steel 8.8; EN 10269 steel
	Studs (RPW45Bi)	Stainless steel A2-70	Stainless steel A2-70
15	Nuts (RPW45BG and RPW45BS)	Steel 8.8; EN 10269 steel	Steel 8.8; EN 10269 steel
	Nuts (RPW45Bi)	Stainless steel A2-70	Stainless steel A2-70
16	* Adjustment spring	Spring steel	Spring steel
17	Lower spring plate (RPW45BG and RPW45BS)	C45E / 1.1191	C45E / 1.1191
	Lower spring plate (RPW45Bi)	AISI 304 / 1.4301	AISI 304 / 1.4301
18	Threaded tube	CuZn39Pb3	CuZn39Pb3
19	Spring adjusting nut (RPW45BG and RPW45BS)	C45E / 1.1191	C45E / 1.1191
	Spring adjusting nut (RPW45Bi)	AISI 304 / 1.4301	AISI 304 / 1.4301
20	Ball bearing	Zinc plated steel	Zinc plated steel
21	Spacer (RPW45BG and RPW45BS)	S355J2G3 / 1.0570	S355J2G3 / 1.0570
	Spacer (RPW45Bi)	AISI 304 / 1.4301	AISI 304 / 1.4301
22	Pressure star (RPW45BG and RPW45BS)	S235JR / 1.0038	S235JR / 1.0038
	Pressure star (RPW45Bi)	AISI 304 / 1.4301	AISI 304 / 1.4301
23	Pressure tube (RPW45BG and RPW45BS)	C45E / 1.1191	C45E / 1.1191
	Pressure tube (RPW45Bi)	AISI 304 / 1.4301	AISI 304 / 1.4301
24	Lock nut (RPW45BG and RPW45BS)	C45E / 1.1191	C45E / 1.1191
	Lock nut (RPW45Bi)	AISI 303 / 1.4305	AISI 303 / 1.4305
25	Pin	AISI 303 / 1.4305	AISI 303 / 1.4305

* Available spare parts.

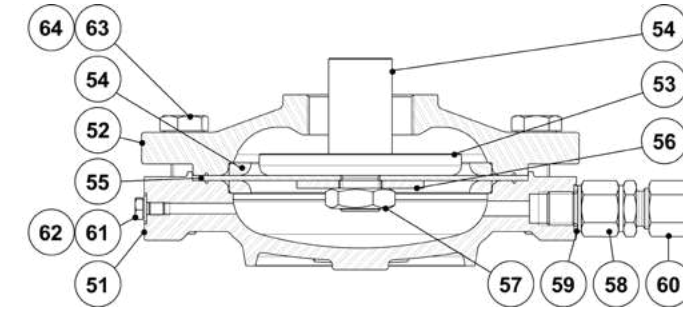

A series

MATERIALS – ACTUATOR				
POS. N°	DESIGNATION	A1, A10, A12, A3 and A4	A2 and A21	A1i, A10i, A12i, A2i, A21i, A3i and A4i
51	Lower diaphragm chamber	A216 WCB / 1.0619	GJS-400-15 / 0.7040 A216 WCB / 1.0619	A351 CF8M / 1.4408
52	Upper diaphragm chamber	A216 WCB / 1.0619	GJS-400-15 / 0.7040 A216 WCB / 1.0619	A351 CF8M / 1.4408
53	Pressure plate	A216 WCB / 1.0619	GJS-400-15 / 0.7040	A351 CF8M / 1.4408 AISI 304 / 1.4301
54	Diaphragm plate spindle	A216 WCB / 1.0619	GJS-400-15 / 0.7040	A351 CF8M / 1.4408 AISI 304 / 1.4301
55	* Diaphragm	Neoprene reinforced polyamid	Neoprene reinforced polyamid	Neoprene reinforced polyamid
56	Washer	Copper	Copper	AISI 304 / 1.4301
57	Hex nut	CuZn39Pb3	CuZn39Pb3	AISI 304 / 1.4301
58	Flow restrictor	AISI 303 / 1.4305	AISI 303 / 1.4305	AISI 303 / 1.4305
59	Gasket	Copper	Copper	Copper
60	Compression fitting	AISI 316Ti / 1.4571	AISI 316Ti / 1.4571	AISI 316Ti / 1.4571
61	Vent screw	Zinc plated steel	Zinc plated steel	AISI 304 / 1.4301
62	Washer	Copper	Copper	AISI 304 / 1.4301
63	Bolts	Zinc plated steel	Zinc plated steel	AISI 304 / 1.4301
64	Nuts	Zinc plated steel	Zinc plated steel	AISI 304 / 1.4301

* Available spare parts.